

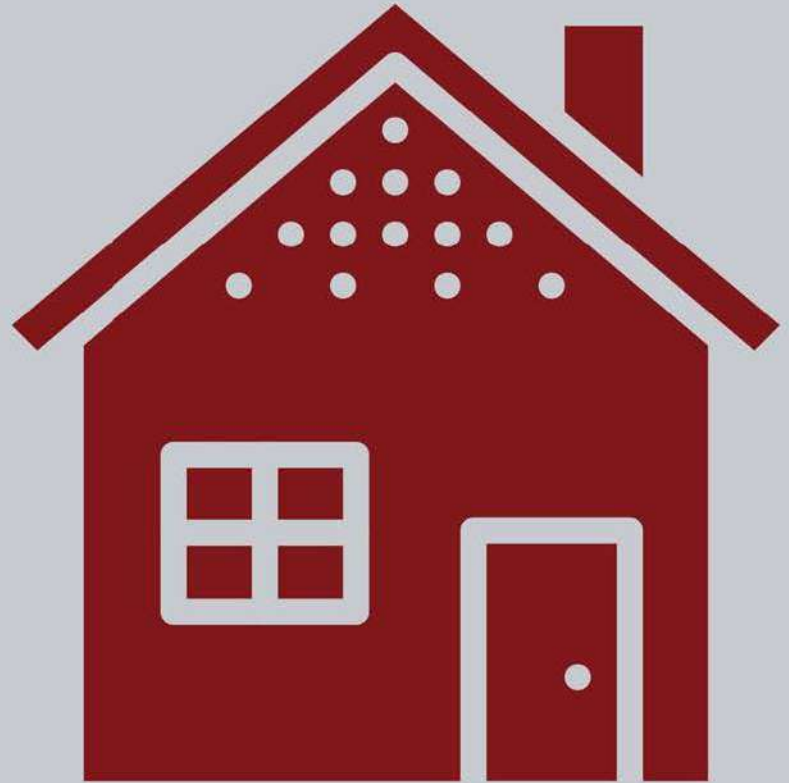

Volume Two



Building Code of Australia
2019

Contents and Introduction

General Table of Contents

Copyright and licence notice

Introduction to the National Construction Code (NCC)

Introduction to NCC Volume Two

General Table of Contents

Contents and Introduction	
Copyright and licence notice.....	7
Introduction to the National Construction Code (NCC)	8
Introduction to NCC Volume Two	10
Section 1 Governing Requirements	
Section 1 Governing Requirements of the NCC	13
Part A1 Interpreting the NCC	14
Part A2 Compliance with the NCC.....	16
Part A3 Application of the NCC in States and Territories.....	20
Part A4 NCC Referenced Documents.....	21
Part A5 Documentation of Design and Construction	23
Part A6 Building Classification.....	28
Section 2 Performance Provisions	
Part 2.0 Application.....	43
Part 2.1 Structure	44
Part 2.2 Damp and weatherproofing	49
Part 2.3 Fire safety	54
Part 2.4 Health and amenity	57
Part 2.5 Safe movement and access	63
Part 2.6 Energy efficiency	66
Part 2.7 Ancillary provisions and additional construction requirements.....	71
Section 3 Acceptable Construction	
How to use Section 3.....	79
Part 3.0 Structural provisions.....	83
Part 3.1 Site Preparation	
Part 3.1 Site preparation.....	90
Part 3.1.1 Earthworks	91
Part 3.1.2 Earth retaining structures	94
Part 3.1.3 Drainage.....	95
Part 3.1.4 Termite risk management.....	101
Part 3.2 Footings and Slabs	
Part 3.2 Footings and slabs	108
Part 3.2.2 Preparation	110
Part 3.2.3 Concrete and reinforcing	116
Part 3.2.4 Site classification.....	119
Part 3.2.5 Footing and slab construction	120
Part 3.3 Masonry	
Part 3.3.1 Unreinforced masonry.....	133
Part 3.3.2 Reinforced masonry	134
Part 3.3.3 Masonry accessories.....	135

Part 3.3.4	Weatherproofing of masonry	136
Part 3.3.5	Masonry veneer	137
Part 3.3.6	Isolated masonry piers	147
Part 3.4 Framing		
Part 3.4.0	Framing	152
Part 3.4.1	Subfloor ventilation	155
Part 3.4.2	Steel framing	159
Part 3.4.3	Timber framing	160
Part 3.4.4	Structural steel members	161
Part 3.5 Roof and Wall Cladding		
Part 3.5	Roof cladding, gutters and downpipes and wall cladding.....	176
Part 3.5.1	Sheet roofing	177
Part 3.5.2	Roof tiles and shingles.....	189
Part 3.5.3	Gutters and downpipes	198
Part 3.5.4	Timber and composite wall cladding	207
Part 3.5.5	Metal wall cladding	218
Part 3.6 Glazing		
Part 3.6	Glazing	221
Part 3.7 Fire Safety		
Part 3.7.1	Fire properties for materials and construction	232
Part 3.7.2	Fire separation of external walls	233
Part 3.7.3	Fire protection of separating walls and floors	259
Part 3.7.4	Fire separation of garage top dwellings	265
Part 3.7.5	Smoke alarms and evacuation lighting	267
Part 3.8 Health and Amenity		
Part 3.8.1	Wet areas and external waterproofing	274
Part 3.8.2	Room heights	279
Part 3.8.3	Facilities.....	281
Part 3.8.4	Light	283
Part 3.8.5	Ventilation.....	287
Part 3.8.6	Sound insulation	290
Part 3.8.7	Condensation management.....	305
Part 3.9 Safe Movement and Access		
Part 3.9.1	Stairway and ramp construction	309
Part 3.9.2	Barriers and handrails.....	318
Part 3.9.3	* * * * *	331
Part 3.10 Ancillary Provisions and Additional Construction Requirements		
Part 3.10.1	Swimming pools	334
Part 3.10.2	Earthquake areas	336
Part 3.10.3	Flood hazard areas	337
Part 3.10.4	Construction in alpine areas.....	338
Part 3.10.5	Construction in bushfire prone areas.....	342
Part 3.10.6	Attachment of decks and balconies to external walls of buildings	343

Part 3.10.7 Boilers, pressure vessels, heating appliances, fireplaces, chimneys and flues	348
Part 3.11 Structural Design Manuals	
Part 3.11 * * * * *	358
Part 3.12 Energy Efficiency	
Part 3.12 Energy efficiency	361
Part 3.12.1 Building fabric	366
Part 3.12.2 External glazing	389
Part 3.12.3 Building sealing	404
Part 3.12.4 Air movement	406
Part 3.12.5 Services	408
Schedule 1 State & Territory Appendices	
Schedule 1 State & Territory Appendices	416
Commonwealth of Australia	
Footnote: Other legislation and policies affecting buildings	419
Australian Capital Territory	
ACT Appendix	423
Footnote: Other legislation affecting buildings	424
New South Wales	
New South Wales additions	427
New South Wales additions	431
New South Wales variations	439
Footnote: Other legislation affecting buildings	440
Northern Territory	
Northern Territory additions	445
Northern Territory variations	446
Footnote: Other legislation affecting buildings	447
Queensland	
Queensland additions	452
Queensland variations	453
Footnote: Other legislation affecting buildings	454
South Australia	
South Australia additions	457
South Australia additions	458
South Australia additions	461
South Australia variations	463
Footnote: Other legislation affecting buildings	464
Tasmania	
Tasmania additions	469
Tasmania additions	470
Tasmania variations	471
Footnote: Other legislation affecting buildings	472

Victoria	
Victoria additions	475
Victoria variations	476
Footnote: Other legislation affecting buildings	477
Western Australia	
Western Australia additions	482
Western Australia variations	484
Footnote: Other legislation affecting buildings	485
Schedule 2 Abbreviations and Symbols	
Schedule 2 Abbreviations and symbols	489
Schedule 3 Definitions	
Schedule 3 Definitions	494
Schedule 4 Referenced Documents	
Schedule 4 Referenced documents	523
Schedule 5 Fire-resistance of Building Elements	
Schedule 5 Fire-resistance of building elements	539
Schedule 6 Fire Hazard Properties	
Schedule 6 Fire hazard properties	549
Schedule 7 Fire Safety Verification Method	
1.0 Preface	554
1.1 Purpose.....	555
1.2 How to use this Verification Method	556
1.3 Performance-based design.....	557
1.4 Design scenarios: NCC Performance Requirements	559
1.5 Fire modelling to determine ASET	562
2.1 Design scenario (BE).....	563
2.2 Design scenario (UT)	564
2.3 Design scenario (CS).....	565
2.4 Design scenario (SF)	566
2.5 Design scenario (HS).....	567
2.6 Design scenario (VS)	568
2.7 Design scenario (IS)	569
2.8 Design scenario (FI).....	570
2.9 Design scenario (UF)	571
2.10 Design scenario (CF)	572
2.11 Design scenario (RC).....	573
2.12 Design Scenario (SS).....	574
History of Amendments	
History of adoption	577
List of Amendments	
List of amendments—NCC 2019—Housing provisions	593

Copyright and licence notice

© Commonwealth of Australia and the States and Territories of Australia 2019, published by the Australian Building Codes Board



The material in this publication is licensed under a Creative Commons Attribution-NonCommercial—4.0 International licence, with the exception of:

- any third party material
- any trade marks, and
- any images or photographs.

You may not make derivatives of this publication, but may only use a verbatim copy. More information on this CC BY NC license is set out at the [Creative Commons Website](#). Enquiries about this publication can be sent to:

Australian Building Codes Board

GPO Box 2013

CANBERRA ACT 2601

Phone: 1300 134 631

Email: ncc@abcb.gov.au

www.abcb.gov.au.

Attribution

Use of all or part of this publication must include the following attribution:

© Commonwealth of Australia and the States and Territories 2019, published by the Australian Building Codes Board.

Disclaimer

By accessing or using this publication, you agree to the following:

While care has been taken in the preparation of this publication, it may not be complete or up-to-date. You can ensure that you are using a complete and up-to-date version by checking the Australian Building Codes Board website (www.abcb.gov.au).

The Australian Building Codes Board, the Commonwealth of Australia and States and Territories of Australia do not accept any liability, including liability for negligence, for any loss (howsoever caused), damage, injury, expense or cost incurred by any person as a result of accessing, using or relying upon this publication, to the maximum extent permitted by law. No representation or warranty is made or given as to the currency, accuracy, reliability, merchantability, fitness for any purpose or completeness of this publication or any information which may appear on any linked websites, or in other linked information sources, and all such representations and warranties are excluded to the extent permitted by law.

This publication is not legal or professional advice. Persons rely upon this publication entirely at their own risk and must take responsibility for assessing the relevance and accuracy of the information in relation to their particular circumstances.

First Published: February 2019

Print version: 1.0

Release date: May 2019

Introduction to the National Construction Code (NCC)

About the NCC

The NCC is Australia's primary set of technical design and construction provisions for buildings. As a performance-based code, it sets the minimum required level for the safety, health, amenity, accessibility and sustainability of certain buildings. It primarily applies to the design and construction of new buildings, and plumbing and drainage systems in new and existing buildings. In some cases it may also apply to structures associated with buildings and new building work or new plumbing and drainage work in existing buildings.

The Australian Building Codes Board (ABCB), on behalf of the Australian Government and each State and Territory government, produces and maintains the NCC. When determining the content of the NCC, the ABCB seeks to—

- ensure requirements have a rigorously tested rationale; and
- effectively and proportionally address applicable issues; and
- create benefits to society that outweigh costs; and
- consider non-regulatory alternatives; and
- consider the competitive effects of regulation; and
- not be unnecessarily restrictive.

The primary users of the NCC include architects, builders, plumbers, building surveyors, hydraulic consultants, engineers and other building and plumbing related professions and trades.

Format of the NCC

The NCC is published in three volumes. The Building Code of Australia (BCA) is Volumes One and Two of the NCC and the Plumbing Code of Australia (PCA) is Volume Three of the NCC.

Components of the NCC

The NCC provides the technical provisions for the design and construction of buildings and other structures, and plumbing and drainage systems.

NCC Volume One primarily covers the design and construction of multi-residential, commercial, industrial and public assembly buildings and some associated structures.

NCC Volume Two primarily covers the design and construction of smaller scale buildings including houses, small sheds, carports and some associated structures.

NCC Volume Three covers the design, construction and maintenance of plumbing and drainage systems in new and existing buildings.

Each volume contains—

- Governing Requirements; and
- Performance Requirements; and
- compliance options to meet the NCC requirements; and
- State and Territory variations and additions.

The NCC uses building classifications to identify requirements for different intended purposes of buildings or parts of buildings. A building classification relates to the characteristics and the intended use of the building. Information on building classifications is found in [Part A6](#) of the Governing Requirements.

Legislative arrangements and the NCC

The NCC is given legal effect through State and Territory, or other statutory authority, building and plumbing legislation. These Acts and Regulations set out the legal framework and administration mechanisms for the NCC to support the design and construction of buildings.

The dates of adoption of the NCC are determined by State and Territory building and plumbing administrations.

How to use the NCC

Each volume of the NCC is split into two main sections:

1. Administrative requirements contained within the Governing Requirements.
2. Technical requirements contained within the remaining sections of the NCC.

The Governing Requirements provide the rules and instructions for using and complying with the NCC. They are vital in understanding how the technical requirements of the NCC should be applied to any particular situation. The Governing Requirements are also important in understanding how the NCC fits with the building and plumbing regulatory framework within Australia.

NCC resources

The NCC has resources created to make the code easier to understand and apply. These resources are available from the ABCB website at: www.abcb.gov.au.

Introduction to NCC Volume Two

About NCC Volume Two

NCC Volume Two contains technical design and construction requirements for certain residential and non-habitable buildings and structures.

Volume Two contains the requirements for—

- Class 1 and 10a buildings (other than access requirements for people with a disability in Class 1b and 10a buildings); and
- certain Class 10b structures (other than access requirements for people with a disability in Class 10b [swimming pools](#)); and
- Class 10c [private bushfire shelters](#).

Components of NCC Volume Two

NCC Volume Two contains the following Sections:

- Section 1 – Governing Requirements
- Section 2 – Performance Requirements and Verification Methods – including—
 - Structure
 - Damp and weatherproofing
 - Fire safety
 - Health and amenity
 - Safe movement and access
 - Ancillary provisions and additional construction requirements
 - Energy efficiency
- Section 3 – Acceptable Construction for Deemed-to-Satisfy Solutions.
- Schedules—
 - State and Territory variations and additions
 - Abbreviations and symbols
 - Definitions
 - Referenced documents
 - Fire-resistance of building elements
 - Fire hazard properties
 - Fire Safety Verification Method

Section 1 contains the mandatory Governing Requirements for the NCC. Section 2 contain the mandatory [Performance Requirements](#). Compliance options to satisfy compliance with the NCC are contained in Sections 2 and/or 3.

Governing Requirements

Section 1	Governing Requirements of the NCC
Part A1	Interpreting the NCC
Part A2	Compliance with the NCC
Part A3	Application of the NCC in States and Territories
Part A4	NCC Referenced Documents
Part A5	Documentation of Design and Construction
Part A6	Building Classification

Section 1 Governing Requirements

Section 1 Governing Requirements of the NCC

Introduction to this Section

Part A1 Interpreting the NCC

Introduction to this Part

A1.0 Interpretation

Part A2 Compliance with the NCC

Introduction to this Part

A2.0 Compliance

A2.1 Compliance with the Performance Requirements

A2.2 Performance Solution

A2.3 Deemed-to-Satisfy Solution

A2.4 A combination of solutions

Part A3 Application of the NCC in States and Territories

Introduction to this Part

A3.0 State and Territory compliance

Part A4 NCC Referenced Documents

Introduction to this Part

A4.0 Referenced documents

A4.1 Differences between referenced documents and the NCC

A4.2 Adoption of referenced documents

Part A5 Documentation of Design and Construction

Introduction to this Part

A5.0 Suitability

A5.1 Evidence of suitability—Volumes One, Two and Three

A5.2 Evidence of suitability—Volumes One and Two

A5.3 Evidence of suitability—Volume Three

A5.4 Fire-resistance of building elements

A5.5 Fire hazard properties

A5.6 Resistance to the incipient spread of fire

Part A6 Building Classification

Introduction to this Part

A6.0 Determining a building classification

A6.1 Class 1 buildings

A6.2 Class 2 buildings

A6.3 Class 3 buildings

A6.4 Class 4 buildings

A6.5 Class 5 buildings

A6.6 Class 6 buildings

A6.7 Class 7 buildings

A6.8 Class 8 buildings

A6.9 Class 9 buildings

A6.10 Class 10 buildings and structures

A6.11 Multiple classifications

Section 1 Governing Requirements of the NCC

Introduction to this Section

The Governing Requirements of the NCC provide the rules and instructions for using and complying with the NCC. They include the following:

- Interpreting the NCC.
- Complying with the NCC.
- Application of the NCC in States and Territories.
- Applying documents referenced in the NCC.
- Documenting the suitability of the design, construction and/or use of materials to comply with the NCC.
- Classifying buildings by their characteristics and intended use.

Part A1 Interpreting the NCC

Introduction to this Part

This Part explains important concepts on how the NCC must be interpreted and applied. There are certain conventions and approaches that need to be taken into account when using the NCC. This includes interpreting specific language and terms. This is critical in understanding the intended technical and legal meaning of the NCC. This Part also explains the difference between the mandatory parts of the NCC and parts that are only explanatory or guidance in nature.

A1.0 Interpretation

- (1) The following components of the NCC are non-mandatory and informative:
 - (a) Content identified as “explanatory information”.
 - (b) For **Volumes One and Two**, the “Introduction to this Part or Section” information, located at the beginning of each Part or Section.
 - (c) For **Volume Three**, the “Introduction to this Section” information, located at the beginning of each Section.
- (2) Words in italics must be interpreted in accordance with—
 - (a) definitions provided in [Schedule 3](#), unless the contrary intention appears; and
 - (b) additional definitions in State or Territory appendices, as appropriate.

Note:

For **Volume Three**, if a word is not defined in [Schedule 3](#), the meaning (if any) attributed to it under AS/NZS 3500.0 Glossary of Terms should be used unless the contrary intention appears.

- (3) The NCC must be interpreted and applied in accordance with the following:
 - (a) A reference to a building is a reference to an entire building or part of a building (as the case requires).
 - (b) A reference to a *plumbing or drainage solution*, or *product* in Volume Three is a reference to an entire installation, system or *product*, or part of an installation, system or *product* (as the case requires).
 - (c) A reference in a *Performance Requirement* to “the degree necessary” means—
 - (i) that consideration of all the criteria referred to in the *Performance Requirement* will determine the outcome appropriate to the circumstances; and
 - (ii) that in certain cases it may not be necessary to incorporate any specific measures to meet the relevant *Performance Requirement*.
 - (d) For **Volume Three** the “Introduction to this Part” information, located at the beginning of each Part, is mandatory and is provided to specify where each Part applies.
 - (e) An “Application” statement is mandatory and is provided to specify where and when a requirement or provision applies.
 - (f) A “Limitation” statement is mandatory and is provided to specify where and when the application of a requirement or provision is limited to a certain circumstance.
 - (g) An “Exemption” statement is mandatory and is provided to specify where or when a requirement or provision does not need to be complied with.
 - (h) A “Note” is part of a provision or requirement and provides additional mandatory instructions.
 - (i) Figures in the NCC are used to illustrate specific issues referenced in the associated text. They are not to be construed as containing all design information that is *required* for that particular building element or situation.
 - (j) The defined symbols and abbreviations listed in [Schedule 2](#).
- (4) A reference to a building class is understood to be a reference to all the sub-classifications of that class.
- (5) The following sub-classifications apply:
 - (a) Classes 1a and 1b are sub-classifications of Class 1.
 - (b) Classes 7a and 7b are sub-classifications of Class 7.

Governing Requirements

- (c) Classes 9a, 9b and 9c are sub-classifications of Class 9.
 - (d) Classes 10a, 10b and 10c are sub-classifications of Class 10.
- (6) A reference to a sub-classification is solely to that sub-classification.

Tas A1.0(7)

Explanatory information:

Explanatory information and Introduction to this Section information contained in the NCC or Introduction to this Part information contained in Volumes One and Two of the NCC are non-mandatory and are provided for guidance purposes only. This informative material should be read in conjunction with the technical provisions of the NCC. Any statements made in the informative and guidance components of the NCC should not be taken to override the NCC. Unlike the NCC, which is adopted by legislation, the informative and guidance components are not called up into legislation and they do not cover State and Territory variations and additions. Because informative and guidance components of the NCC do not have regulatory force, the ABCB accepts no responsibility for its contents when applied to specific buildings or any liability which may result from its use.

Defined words provide the precise meaning and expressions of key words used for understanding and complying with the NCC. Where a word is not defined in the NCC, the relevant common meaning of the word should be used.

Generally, a reference to a building is a reference to the whole building, regardless of classification. However, when a provision is applicable to a specific class or classes of building, that reference to a building may be a reference to the whole building or part of the building depending on how the building is classified.

Whether a provision applies or not depends on the circumstances of the case and the circumstances in which the reference is made. For example, where a building has a single classification, a reference to a building in the NCC is understandably a reference to a whole building. However, where a building has parts of different classification, unless the contrary intention appears (i.e. there is a specific reference to the whole building), a reference to a building in the NCC is a reference to the relevant part of the building. This means that each part of the building must comply with the relevant provisions for its classification.

A number of the *Performance Requirements* of the NCC use the expression “to the degree necessary” or “appropriate to”. These expressions provide flexibility by allowing *appropriate authorities* to determine the degree of compliance necessary in a particular case. Therefore any part of the NCC that uses these expressions should be referenced against the requirements of the *appropriate authority*. For example, an *appropriate authority* might judge that an item need not be installed, or a particular level of performance be achieved.

Application, Limitation, and Exemption statements are used to identify provisions that may or may not apply in certain situations, to varying degrees.

Classes 1a and 1b, 7a and 7b, 9a, 9b and 9c, and 10a, 10b and 10c are separate classifications. In the NCC, when the designation ‘a’, ‘b’ or ‘c’ is not applied, the reference is to all buildings of the general class. For example, ‘Class 9b’ refers only to Class 9b buildings, but ‘Class 9’ refers to Classes 9a, 9b and 9c.

Figures are used to explain the requirements of a particular clause. To ensure the context of the requirement is clearly understood, adjacent construction elements of the building that would normally be *required* in that particular situation are not always shown. Accordingly, aspects of figures that are not shown should not be interpreted as meaning these construction details are not *required*. Therefore a figure must not be used as an indication of the full construction requirements in a given situation, as the only available option, or a substitute for referencing appropriate construction requirements (in other sources) for a given clause.

Part A2 Compliance with the NCC

Introduction to this Part

This Part explains the possible methods of demonstrating compliance with the NCC. It explains the various compliance pathways within the NCC and the appropriate steps that must be taken for each of these pathways.

A2.0 Compliance

Compliance with the NCC is achieved by complying with—

- (1) the Governing Requirements of the NCC; and
- (2) the *Performance Requirements*.

A2.1 Compliance with the Performance Requirements

Performance Requirements are satisfied by one of the following, as shown in Figure 1:

- (1) A *Performance Solution*.
- (2) A *Deemed-to-Satisfy Solution*.
- (3) A combination of (1) and (2).

Figure 1: NCC compliance option structure

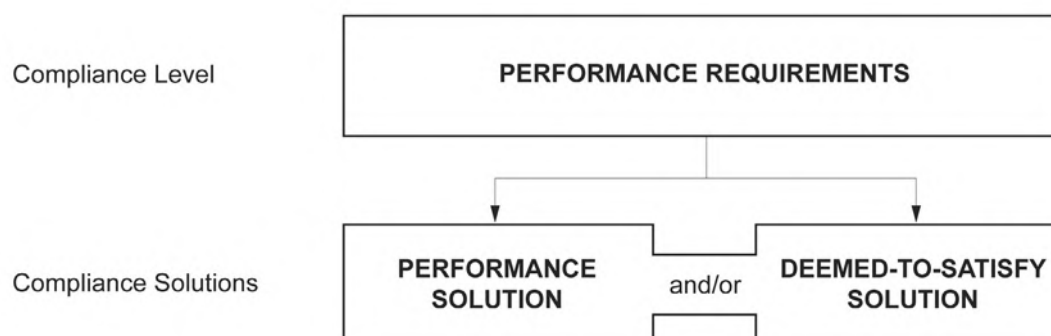

A2.2 Performance Solution

- (1) A *Performance Solution* is achieved by demonstrating—
 - (a) compliance with all relevant *Performance Requirements*; or
 - (b) the solution is at least *equivalent* to the *Deemed-to-Satisfy Provisions*.
- (2) A *Performance Solution* must be shown to comply with the relevant *Performance Requirements* through one or a combination of the following *Assessment Methods*:
 - (a) Evidence of suitability in accordance with Part A5 that shows the use of a material, product, *plumbing* and *drainage product*, form of construction or design meets the relevant *Performance Requirements*.
 - (b) A *Verification Method* including the following:
 - (i) The *Verification Methods* provided in the NCC.
 - (ii) Other *Verification Methods*, accepted by the *appropriate authority* that show compliance with the relevant *Performance Requirements*.
 - (c) *Expert Judgement*.
 - (d) Comparison with the *Deemed-to-Satisfy Provisions*.
- (3) Where a *Performance Requirement* is satisfied entirely by a *Performance Solution*, in order to comply with (1) the

Governing Requirements

following method must be used to determine the *Performance Requirement* or *Performance Requirements* relevant to the *Performance Solution*:

- (a) Identify the relevant *Performance Requirements* from the Section or Part to which the *Performance Solution* applies.
- (b) Identify *Performance Requirements* from other Sections or Parts that are relevant to any aspects of the *Performance Solution* proposed or that are affected by the application of the *Performance Solution*.

A2.3 Deemed-to-Satisfy Solution

- (1) A solution that complies with the *Deemed-to-Satisfy Provisions* is deemed to have met the *Performance Requirements*.
- (2) A *Deemed-to-Satisfy Solution* can show compliance with the *Deemed-to-Satisfy Provisions* through one or more of the following *Assessment Methods*:
 - (a) Evidence of suitability in accordance with *Part A5* that shows the use of a material, product, *plumbing* and *drainage product*, form of construction or design meets a *Deemed-to-Satisfy Provision*.
 - (b) *Expert Judgement*.
- (3) For **Volume Two**:
 - (a) Where an acceptable construction manual and an acceptable construction practice contained in the same Part are considered to satisfy the same component of a *Performance Requirement*, in order to comply with the *Deemed-to-Satisfy Provisions* it is only necessary to satisfy—
 - (i) the appropriate acceptable construction manual; or
 - (ii) the appropriate acceptable construction practice.
 - (b) Where an acceptable construction manual and an acceptable construction practice contained in the same Part are deemed to satisfy different components of a *Performance Requirement*, compliance with the *Deemed-to-Satisfy Provisions* may require satisfying both the listed acceptable construction manual and the acceptable construction practice for their specific components unless otherwise stated.

A2.4 A combination of solutions

- (1) *Performance Requirements* may be satisfied by using a combination of *Performance Solutions* and *Deemed-to-Satisfy Solutions*.
- (2) When using a combination of solutions, compliance can be shown through the following, as appropriate:
 - (a) *A2.2* for assessment against the relevant *Performance Requirements*.
 - (b) *A2.3* for assessment against the relevant *Deemed-to-Satisfy Provisions*.
- (3) Where a *Performance Requirement* is satisfied by a *Performance Solution* in combination with a *Deemed-to-Satisfy Solution*, in order to comply with (1), the following method must be used to determine the *Performance Requirement* or *Performance Requirements* relevant to the *Performance Solution*:
 - (a) Identify the relevant *Deemed-to-Satisfy Provisions* of each Section or Part that are to be the subject of the *Performance Solution*.
 - (b) Identify the *Performance Requirements* from the same Sections or Parts that are relevant to the identified *Deemed-to-Satisfy Provisions*.
 - (c) Identify *Performance Requirements* from other Sections or Parts that are relevant to any aspects of the *Performance Solution* proposed or that are affected by the application of the *Deemed-to-Satisfy Provisions* that are the subject of the *Performance Solution*.

Explanatory information:

To comply with the NCC, a solution must achieve compliance with the Governing Requirements and the *Performance Requirements*. The Governing Requirements contain requirements about how the *Performance Requirements* must be met.

Performance Requirements outline the minimum necessary standards different buildings or building elements must attain. The *Performance Requirements* are the only NCC technical provisions that must be satisfied.

In some instances, State and Territory variations and additions may also be applicable to certain *Performance*

Governing Requirements

Requirements.

A solution may be partly a *Performance Solution* and partly a *Deemed-to-Satisfy Solution*. However, no matter what method is chosen, building proponents need to always meet the *Performance Requirements* of the NCC.

A2.2(2)(b)(ii) provides for the use of *Verification Methods* that are not listed in the NCC. A *Verification Method* may include—

1. a calculation, using analytical methods or mathematical models; or
2. a test, using a technical procedure, either on-site or in a laboratory, to directly measure the extent to which the *Performance Requirements* have been met; or
3. an inspection (and inspection report); or
4. any other acceptable form of certification.

Any *Verification Method* used must be acceptable to the *appropriate authority*.

A *Performance Solution* must comply with all applicable *Performance Requirements* of the NCC. A *Performance Solution* provides a tailored solution to meet the intended objective of the *Performance Requirements*. A *Performance Solution* must comply with all relevant *Performance Requirements* and must be verified using one or a combination of the following *Assessment Methods*:

- Evidence of suitability.
- *Verification Method*.
- *Expert Judgement*.
- Comparison with the *Deemed-to-Satisfy Provisions*.

For example, building proponents who wish to know what has to be done to satisfy the fire safety *Performance Requirements* for a particular building can either follow the *Deemed-to-Satisfy Provisions* or develop a *Performance Solution*. Guidance on how to develop *Performance Solutions* can be found on the ABCB website at: www.abcb.gov.au. The ABCB Resource Library contains information on the development of *Performance Solutions* for both building and plumbing.

A *Deemed-to-Satisfy Solution* is achieved by following all appropriate *Deemed-to-Satisfy Provisions* in the NCC. The *Deemed-to-Satisfy Provisions* are prescriptive (i.e. like a recipe book, they tell you how, what and in which location things must be done). They include materials, components, design factors, and construction methods that, if used, are deemed to meet the *Performance Requirements*, hence the term “Deemed-to-Satisfy”.

A *Deemed-to-Satisfy Solution* may be verified using one or a combination of the following *Assessment Methods*:

- Evidence of suitability.
- *Expert Judgement*.

Some *Performance Requirements* are without *Deemed-to-Satisfy Solutions*. Compliance with these *Performance Requirements* must be achieved by using a *Performance Solution*.

In Section 3 of Volume Two the *Deemed-to-Satisfy Provisions* are divided into two compliance pathways: “acceptable construction practices” and “acceptable construction manuals”:

- “Acceptable construction practices” are some of the most common forms of national construction practices and are written into Section 3.
- “Acceptable construction manuals” are the deemed-to-satisfy referenced documents.

In general, either an “acceptable construction practice” or an “acceptable construction manual” may be used as options when proposing a *Deemed-to-Satisfy Solution*.

Acceptable construction practices are *Deemed-to-Satisfy Provisions* that are considered to meet the legislative requirements for Class 1 and Class 10 buildings.

There is no obligation to adopt any particular option contained in the acceptable construction practices, if it is preferred to meet the *Performance Requirement* in some other way.

However, if one of the options described in these provisions is not complied with, then the *appropriate authority* must be satisfied that the *Performance Requirements* have been met.

When designing a building or *plumbing* or *drainage* system, both *Performance Solutions* and *Deemed-to-Satisfy Solutions* can be used to achieve compliance with *Performance Requirements*. A combination of solutions may be used to satisfy a single *Performance Requirement*. This may include occasions where a specific *Performance Requirement* covers a number of elements of a building or *plumbing* or *drainage* system.

No NCC provision can be considered in isolation. Any departure from the *Deemed-to-Satisfy Provisions* for a *Performance Solution* needs to be assessed against the relevant *Performance Requirements* within the relevant NCC

Governing Requirements

Section or Part. Additionally, the proposed *Performance Solution* may also impact on other *Performance Requirements* in other Sections or Parts. Thus, these additional *Performance Requirements* need to be considered in relation to the subject *Performance Solution*. A2.2(3) and A2.4(3) set out the methods for determining which *Performance Requirements* are relevant.

It is important that a holistic approach is used when determining the appropriate *Performance Requirements*.

More information on NCC compliance methods is located at www.abcb.gov.au.

Part A3 Application of the NCC in States and Territories

Introduction to this Part

This Part explains applying the NCC in accordance with State or Territory legislation. The NCC has legal effect through references in relevant State and Territory building and plumbing legislation.

Although the NCC is a nationally consistent code, there are some situations where a State or Territory enforce a variation, addition or deletion to it. This Part also explains how these variations, additions and deletions apply.

A3.0 State and Territory compliance

- (1) For application within a particular State or Territory, the Volumes of the NCC comprise inclusively of—
 - (a) Sections A to J and associated schedules of Volume One; and
 - (b) Sections 1 to 3 and associated schedules of Volume Two; and
 - (c) Sections A to E and associated schedules of Volume Three.
- (2) State or Territory variations, additions and deletions must be complied with in conjunction with the NCC.
- (3) The NCC is subject to, and may be overridden by, State or Territory legislation.
- (4) For Volumes One and Three, State and Territory variations, additions and deletions are contained in [Schedule 1](#).
- (5) For Volume Two, State and Territory variations, additions and deletions are contained throughout the Volume and in [Schedule 1](#).
- (6) State and Territory variations and deletions are identified throughout the NCC.

Explanatory information:

The NCC is given legal effect by building regulatory legislation in each State and Territory. This legislation consists of an Act of Parliament and subordinate legislation which empowers the regulation of certain aspects of building and plumbing, and contains the administrative provisions necessary to give effect to the legislation.

Although the NCC is a national code, in some instances it is necessary for a State or Territory to vary or apply additional requirements specific to their jurisdiction. [A3.0\(2\)](#) highlights that these variations, additions or deletions must be applied in conjunction with the NCC provisions. Typically, these variations, additions or deletions override the requirements contained within the NCC.

Any provision of the NCC may be overridden by, or subject to, State or Territory legislation. The NCC must therefore be read in conjunction with that legislation. Any queries on such matters should be referred to the State or Territory authority responsible for building and plumbing regulatory matters.

Where a requirement or provision of the NCC is subject to a State or Territory variation, addition, or deletion, a reference to the appropriate provision in [Schedule 1](#) is included with that requirement or provision.

Part A4 NCC Referenced Documents

Introduction to this Part

This Part explains how documents referenced in the NCC are adopted and applied. The NCC itself does not contain details of every design and construction requirement for a building or *plumbing* or *drainage* system. As such, the NCC calls upon or “references” other documents with this information. These are called NCC referenced documents. Examples of these are Australian Standards, ABCB protocols, ABCB standards and other publications.

There are multiple types of referenced documents. A primary referenced document is one referenced in [Schedule 4](#) of the NCC. A secondary referenced document is one referenced in a primary referenced document. Other referenced documents are referenced by secondary and subsequently referenced documents.

A4.0 Referenced documents

- (1) A reference in the NCC to a document refers to the edition or issue and any amendment listed in [Schedule 4](#).
- (2) A document referenced in the NCC is only applicable in the context in which the document is quoted.

Volume Three Tas A4.0(3)

- (3) Where a new edition, issue or amendment of a primary referenced document is not listed under [Schedule 4](#), the new edition, issue or amendment is not referenced for the purposes of the NCC.
- (4) Any document referenced in a primary referenced document is known as a secondary referenced document.
- (5) A reference in a primary referenced document to a secondary or other referenced document is a reference to the document as it existed at the time of publication of the primary referenced document.

Exemption 1:

If the secondary or other referenced document is also a primary referenced document, [A4.0\(5\)](#) does not apply.

A4.1 Differences between referenced documents and the NCC

The NCC overrules any difference between the NCC and a primary referenced document, including any secondary referenced document.

Exemption 1:

[A4.1](#) does not apply to acceptable construction manuals when used in their entirety to comply with requirements of the NCC unless otherwise stated.

A4.2 Adoption of referenced documents

The NCC does not require compliance with requirements in relation to the following matters where they are prescribed in a referenced document:

- (1) The rights, responsibilities or obligations between the manufacturer, supplier or purchaser.
- (2) The responsibilities of any trades person or other building operative, architect, engineer, authority, or other person or body.
- (3) The submission for approval of any material, building component, form or method of construction, to any person, authority or body other than those empowered under State or Territory legislation to give that approval.
- (4) The submission of a material, product, form of construction or design to any person, authority or body for an opinion.
- (5) Any departure from the NCC, rule, specification or provision at the sole discretion of the manufacturer or purchaser, or by arrangement or agreement between the manufacturer and purchaser.

Explanatory information:

[Schedule 4](#) is only mandatory to *Deemed-to-Satisfy Provisions*, *Verification Methods* and [Schedules 3, 5 and 6](#). However, referenced documents are only applicable to the NCC provision that references the document.

A proponent undertaking a *Performance Solution* can use any element or edition of any document, if they help satisfy the *Performance Requirements*. They do not need to use the documents listed in [Schedule 4](#).

Governing Requirements

[Schedule 4](#) lists the specific edition of the Standard or other document adopted, including any amendments considered appropriate for [Schedule 3](#), the *Deemed-to-Satisfy Provisions* or *Verification Methods*. Other editions of (or amendments to) the referenced document are not adopted and have no standing under the NCC.

A primary referenced document may refer to a secondary referenced document. [A4.0\(5\)](#) stipulates that the secondary referenced document is the edition of the document that existed at the time of publication of the primary referenced document. When another edition of (or amendment to) a secondary referenced document is released, subject to [A4.0 Exemption 1](#), that edition (or amendment) is not adopted for the purposes of the primary referenced document.

[A4.2](#) means that contractual matters or clauses defining responsibilities of various parties, and matters not appropriate for adoption in the NCC are not included when a document is called up in the NCC.

Part A5 Documentation of Design and Construction

Introduction to this Part

This Part explains the evidence needed to show that the NCC requirements are met and the solution is “fit for purpose”. It covers the use of materials, products, forms of construction and designs. It details separate requirements for the BCA and PCA.

Examples of evidence to be prepared and retained include certificates, reports, calculations and any other documents or information showing compliance with the NCC requirements.

A5.0 Suitability

- (1) A building and *plumbing* or *drainage* installation must be constructed using materials, products, *plumbing products*, forms of construction and designs fit for their intended purpose to achieve the relevant requirements of the NCC.
- (2) For the purposes of (1), a material, product, *plumbing product*, form of construction or design is fit for purpose if it is—
 - (a) supported by evidence of suitability in accordance with—
 - (i) [A5.1](#); and
 - (ii) [A5.2](#) or [A5.3](#) as appropriate; and
 - (b) constructed or installed in an appropriate manner.

A5.1 Evidence of suitability—Volumes One, Two and Three

- (1) The form of evidence used must be appropriate to the use of the material, product, *plumbing product*, form of construction or design to which it relates.
- (2) Any copy of documentary evidence submitted must be a complete copy of the original certificate, report or document.

A5.2 Evidence of suitability—Volumes One and Two

Application 1:

[A5.2](#) is only applicable to the BCA.

- (1) Subject to [A5.4](#), [A5.5](#) and [A5.6](#), evidence to support that the use of a material, product, form of construction or design meets a *Performance Requirement* or a *Deemed-to-Satisfy Provision* may be in the form of any one, or any combination of the following:
 - (a) A current CodeMark Australia or CodeMark *Certificate of Conformity*.
 - (b) A current *Certificate of Accreditation*.
 - (c) A current certificate, other than a certificate described in (a) and (b), issued by a *certification body* stating that the properties and performance of a material, product, form of construction or design fulfil specific requirements of the BCA.
 - (d) A report issued by an *Accredited Testing Laboratory* that—
 - (i) demonstrates that a material, product or form of construction fulfils specific requirements of the BCA; and
 - (ii) sets out the tests the material, product or form of construction has been subjected to and the results of those tests and any other relevant information that has been relied upon to demonstrate it fulfils specific requirements of the BCA.
 - (e) A certificate or report from a *professional engineer* or other *appropriately qualified person* that—
 - (i) certifies that a material, product, form of construction or design fulfils specific requirements of the BCA; and
 - (ii) sets out the basis on which it is given and the extent to which relevant standards, specifications, rules, codes of practice or other publications have been relied upon to demonstrate it fulfils specific requirements of the BCA.

Governing Requirements

- (f) Another form of documentary evidence, such as but not limited to a *Product Technical Statement*, that—
 - (i) demonstrates that a material, product, form of construction or design fulfils specific requirements of the BCA; and
 - (ii) sets out the basis on which it is given and the extent to which relevant standards, specifications, rules, codes of practice or other publications have been relied upon to demonstrate it fulfils specific requirements of the BCA.
- (2) Evidence to support that a calculation method complies with an ABCB protocol may be in the form of any one, or any combination of the following:
 - (a) A certificate from a *professional engineer* or other *appropriately qualified person* that—
 - (i) certifies that the calculation method complies with a relevant ABCB protocol; and
 - (ii) sets out the basis on which it is given and the extent to which relevant standards, specifications, rules, codes of practice and other publications have been relied upon.
 - (b) Another form of documentary evidence that correctly describes how the calculation method complies with a relevant ABCB protocol.

A5.3 Evidence of suitability—Volume Three

Application 1:

A5.3 is only applicable to the PCA.

- (1) Any *product* that is intended for use in contact with *drinking water* must comply with the relevant requirements of AS/NZS 4020 in the form of either—

Tas A5.3(1)(a)

- (a) a test report provided by a *certification body* or *Accredited Testing Laboratory*, in accordance with AS/NZS 4020; or
- (b) a *WaterMark Licence* issued in accordance with (2), if it includes compliance with AS/NZS 4020.

Tas A5.3(1)(c)

- (2) A *product* of a type listed on the *WaterMark Schedule of Products* is deemed to be fit for its intended purpose if it has a *WaterMark Licence* issued in accordance with the WaterMark Scheme Rules.
- (3) A *product* of a type listed on the *WaterMark Schedule of Excluded Products* requires evidence of suitability in the form of—
 - (a) a current certificate issued by a *certification body* stating that the properties and performance of a *product* can meet the requirements of the PCA; or

Tas A5.3(3)(b)

- (b) a report issued by an *Accredited Testing Laboratory* that—
 - (i) demonstrates that the *product* complies with the relevant requirements of the PCA; and
 - (ii) sets out the tests the *product* has been submitted to and the results of those tests and any other relevant information that has been relied upon to demonstrate suitability for use in a *plumbing* or *drainage* installation.

- (4) Any *product* that is not covered by (2) or (3) must be subjected to a risk assessment in accordance with the WaterMark Scheme Rules.

Tas A5.3(401)

- (5) Evidence to support that a design or system meets the relevant PCA *Performance Requirements* must be in the form of any one or any combination of the following:
 - (a) The design or system complies with a *Deemed-to-Satisfy Provision*.
 - (b) The design or system is a *Performance Solution* from a *professional engineer* or a *recognised expert* that—
 - (i) certifies that the design or system complies with the relevant requirements of the PCA; and
 - (ii) sets out the basis on which it is given and the extent to which relevant standards, specifications, rules, codes of practice or other publications have been relied upon.

Governing Requirements

Tas A5.3(5)(b)(iii)

- (6) Any other form of documentary evidence that—
- (a) demonstrates that a design or system complies with the relevant requirements of the PCA; and
 - (b) sets out the basis on which it is given and the extent to which relevant standards, specifications, rules, codes of practice or other publications have been relied upon.

Tas A5.3(7), (8), (9), (10)

A5.4 Fire-resistance of building elements

Where a *Deemed-to-Satisfy Provision* requires a building element to have an FRL, it must be determined in accordance with [Schedule 5](#).

A5.5 Fire hazard properties

Where a *Deemed-to-Satisfy Provision* requires a building component or assembly to have a *fire hazard property* it must be determined as follows:

- (1) For *average specific extinction area*, *critical radiant flux* and *Flammability Index*, as defined in [Schedule 3](#).
- (2) For *Smoke-Developed Index* and *Spread-of-Flame Index*, in accordance with [Schedule 6](#).
- (3) For a material's *group number* or *smoke growth rate index* (SMOGR_{RC}), in accordance with [Clause 4\(b\)](#) of [Specification C1.10](#).

A5.6 Resistance to the incipient spread of fire

A ceiling is deemed to have a *resistance to the incipient spread of fire* to the space above itself if—

- (1) it is identical with a prototype that has been submitted to the *Standard Fire Test* and the *resistance to the incipient spread of fire* achieved by the prototype is confirmed in a report from an *Accredited Testing Laboratory* that—
 - (a) describes the method and conditions of the test and form of construction of the tested prototype in full; and
 - (b) certifies that the application of restraint to the prototype complies with the *Standard Fire Test*; or
- (2) it differs in only a minor degree from a prototype tested under (1) and the *resistance to the incipient spread of fire* attributed to the ceiling is confirmed in a report from an *Accredited Testing Laboratory* that—
 - (a) certifies that the ceiling is capable of achieving the *resistance to the incipient spread of fire* despite the minor departures from the tested prototype; and
 - (b) describes the materials, construction and conditions of restraint that are necessary to achieve the *resistance to the incipient spread of fire*.

ACT Appendix

Explanatory information:

[A5.0](#) relates to the quality of work and materials needed to construct a building to meet NCC requirements.

This means that—

- all people involved with construction must work skillfully in accordance with good trade practice; and
- all materials must be of a quality to fulfil their function/s within the building.

[A5.0](#) only applies to matters normally covered by the NCC.

While [A5.0](#) outlines quality of work and material demands, sometimes additional conditions may be required by—

- other Commonwealth, State or Territory legislation; and
- contracts that include either specific quality requirements, or requirements for specific materials and the like.

Example

Permit authorities would ordinarily not apply [A5.0](#) to such matters as—

- plastering—other than for fire rating, waterproofing of *wet areas*, and sound insulation; or
- painting—other than that *required* for weatherproofing an *external wall*.

When determining which form of evidence will be used, it is important to consider the appropriateness of the evidence, as some forms of evidence may be more suitable to materials and products and others to designs and forms of

Governing Requirements

construction. The requirement to consider appropriateness of the evidence is specified in [A5.1\(1\)](#).

For further guidance, refer to the ABCB Handbook for Evidence of Suitability.

All copies of documents provided as evidence must be unabridged copies of the originals. No part can be left incomplete.

[A5.2](#) represents the minimum level of documentary evidence needed to show that a material, product, form of construction or design meets the relevant NCC requirements. The evidence can be required by:

- an *appropriate authority*;
- a party to a construction contract; or
- a person certifying compliance with the NCC.

If a building proponent does not produce exactly what is required, the evidence may be rejected.

It should be noted that design may refer to engineering design, architectural design as well as product and material design.

[A5.2\(1\)\(f\)](#) allows for the use of alternative forms of documentary evidence to those included in [A5.2\(1\)\(a\)](#) to [\(e\)](#), as long as they comply with certain specified conditions.

An example of this arises when an authority carries out an inspection of a building site. The inspection alone would not be acceptable as evidence. However, if the authority compiled a written report detailing findings and conclusions from the inspection, then it may comply with the requirements of [A5.2\(1\)\(f\)](#).

A *Product Technical Statement* detailing the characteristics and merits of a particular product or system is also an example of another form of documentary evidence.

There is significant reliance by industry on the use of calculation methods, including software programs, for demonstrating compliance with the NCC. While there is no formal recognition of specific methods, [A5.2\(2\)](#) allows suitable evidence to be submitted to demonstrate that a calculation method (including a software program) complies with a relevant ABCB protocol that establishes the characteristics of a suitable calculation method.

[A5.3\(1\)](#) requires any *product* intended for use in contact with *drinking water* to comply with AS/NZS 4020. Compliance is achieved by passing the relevant tests set out in the Standard. Evidence of compliance must then be provided in accordance with [A5.3\(1\)](#), under which there are two options. The first, at [A5.3\(1\)\(a\)](#), recognises test reports and certificates that cover compliance with AS/NZS 4020 only. The second, at [A5.3\(1\)\(b\)](#), recognises *WaterMark Licences* where compliance with AS/NZS 4020 is a requirement of the relevant *product* Standard or WaterMark Technical Specification.

For *products* that are of a type listed on the *WaterMark Schedule of Products*, [A5.3\(2\)](#) requires that these *products* have a *WaterMark Licence*. A *WaterMark Licence* reflects that the *product* has been certified and authorised in accordance with the WaterMark Scheme Rules.

For *products* that are not subject to WaterMark certification (i.e. excluded *products*), evidence that can be used to support that the *product* is fit for its intended purpose is provided in [A5.3\(3\)](#). This may include demonstrating compliance with a *product* specification referenced in the *WaterMark Schedule of Excluded Products*, where one is available.

[A5.3\(4\)](#) provides that any product that is not listed on the *WaterMark Schedule of Products* or the *WaterMark Schedule of Excluded Products* must be subjected to a risk assessment in accordance with the WaterMark Scheme Rules. The risk assessment will determine whether the product in question requires certification and authorisation, or if it should be listed as an “excluded product”. This in turn will determine the form of evidence of suitability applicable to the *product*.

What is WaterMark?

The *WaterMark Certification Scheme* is a mandatory certification scheme for *plumbing* and *drainage products* to ensure that these *products* are fit for purpose and appropriately authorised for use in a *plumbing* or *drainage* system.

The PCA, through [Part A5](#), requires certain *plumbing* and *drainage products* to be certified and authorised for use in a *plumbing* or *drainage* system. These *products* are certified through the *WaterMark Certification Scheme* and listed on the WaterMark Product Database.

The *WaterMark Certification Scheme* is governed by the WaterMark Scheme Rules, which are available for download from the ABCB website at: www.abcb.gov.au. These rules set out the requirements for risk assessments, evaluation, certification, and the drafting of WaterMark Technical Specifications.

When a *product* is listed on the *WaterMark Schedule of Products* then, for it to be certified and authorised, the *product* must—

- be tested by an *Accredited Testing Laboratory*; and
- comply with an approved *product* specification (either a relevant existing *product* Standard or a WaterMark Technical Specification); and
- be manufactured in accordance with an approved Quality Assurance Program; and

Governing Requirements

- carry a scope of use.

Products that comply fully with the applicable requirements of the *WaterMark Certification Scheme* are then eligible to be certified by a *WaterMark Conformity Assessment Body* and listed on the WaterMark Product Database. Certified *products* are identifiable by the WaterMark certification trade mark, shown below, that must be displayed on the *product* upon granting of a *WaterMark Licence*.

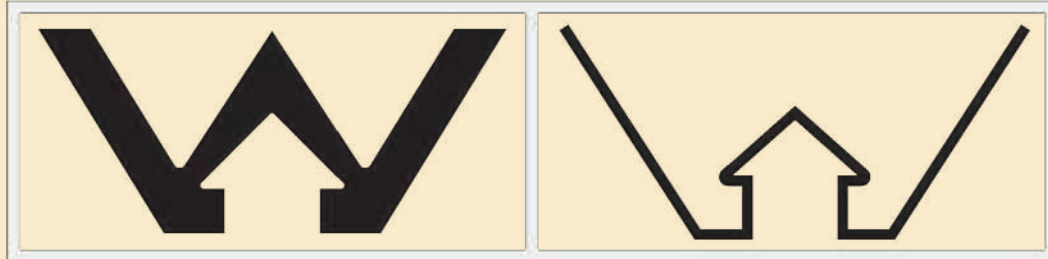

If under a *Deemed-to-Satisfy Provision* a building element is *required* to have an FRL, then *A5.2* may be used to provide evidence to show that the FRL has been determined in accordance with *Schedule 5*.

In the case of a test report from an *Accredited Testing Laboratory*, the report may be either—

- the test report referred to in clause 2.16.2 of AS 1530.4 (also referred to as a full test report); or
- the regulatory information report referred to in clause 2.16.3 of AS 1530.4 (also referred to as a short-form report).

In both cases the report must be an unabridged copy of the original report. A test certificate referred to in clause 2.16.4 of AS 1530.4 on its own is not suitable for showing compliance with the NCC.

If a proposal uses a *Deemed-to-Satisfy Provision* that requires a building element to have *fire hazard properties*, then *A5.2* may be used to provide evidence to support the proposal and show that the *fire hazard properties* have been determined in accordance with *A5.5*.

Refer to the guidance provided in the Guide to Volume One for further information on *fire hazard properties* which includes—

- *Flammability Index*; and
- *Spread-of-Flame Index*; and
- *Smoke-Developed Index*; and
- a material's *group number*; and
- *smoke growth rate index*.

The *Deemed-to-Satisfy Provisions* of the BCA contain a number of provisions requiring a ceiling to have a *resistance to the incipient spread of fire* to the space above itself. *A5.6* sets out the method of determining the incipient spread of fire. The method is based on the method of determining the FRL of a building element and use of the *Standard Fire Test*.

Part A6 Building Classification

Introduction to this Part

The NCC groups buildings and structures by the purpose for which they are designed, constructed or adapted to be used, rather than by the function or use they are put to, assigning each type of building or structure with a classification. This Part explains how each building classification is defined and used in the NCC.

The building classifications are labelled “Class 1” through to “Class 10”. Some classifications also have sub-classifications, referred to by a letter after the number (e.g. Class 1a).

The technical building requirements for Class 2 to 9 buildings are mostly covered by Volume One of the NCC and those for Class 1 and 10 buildings are mostly covered by Volume Two of the NCC. Volume Three of the NCC covers *plumbing* and *drainage* requirements for all building classifications.

A building may have parts that have been designed, constructed or adapted for different purposes. In most cases, each of these parts is a separate classification. A building (or part of a building) may also have more than one such purpose and may be assigned more than one classification.

A6.0 Determining a building classification

- (1) The classification of a building or part of a building is determined by the purpose for which it is designed, constructed or adapted to be used.
- (2) Each part of a building must be classified according to its purpose and comply with all the appropriate requirements for its classification.

Exemption 1:

For A6.0(1) where a part of a building has been designed, constructed or adapted for a different purpose and is less than 10% of the *floor area* of the *storey* it is situated on, the classification of the other part of the *storey* may apply to the whole *storey*.

Limitation 1:

Exemption 1 does not apply where the minor use of a building is a laboratory or a Class 2, 3 or 4 part of a building.

- (3) A room that contains a mechanical, thermal or electrical facility or the like that serves the building must have the same classification as the major part or principal use of the building or *fire compartment* in which it is situated.

Exemption 2:

A6.0(3) does not apply to an *electricity network substation*.

- (4) Unless another classification is more suitable an *occupiable outdoor area* must have the same classification as the part of the building to which it is associated.

A6.1 Class 1 buildings

A Class 1 building includes one or more of the following sub-classifications:

- (1) Class 1a is one or more buildings, which together form a single dwelling including the following:
 - (a) A detached house.
 - (b) One of a group of two or more attached dwellings, each being a building, separated by a *fire-resisting* wall, including a row house, terrace house, town house or villa unit.
- (2) Class 1b is one or more buildings which together constitute—
 - (a) a boarding house, guest house, hostel or the like that—
 - (i) would ordinarily accommodate not more than 12 people; and
 - (ii) have a total area of all floors not more than 300 m² (measured over the enclosing walls of the building or buildings); or
 - (b) four or more single dwellings located on one allotment and used for short-term holiday accommodation.

Governing Requirements

Limitation 1:

For A6.1, a Class 1 building cannot be located above or below another dwelling or another Class of building, other than a *private garage*.

See Figures 1, 2 and 3.

Figure 1: Identification of Class 1 buildings

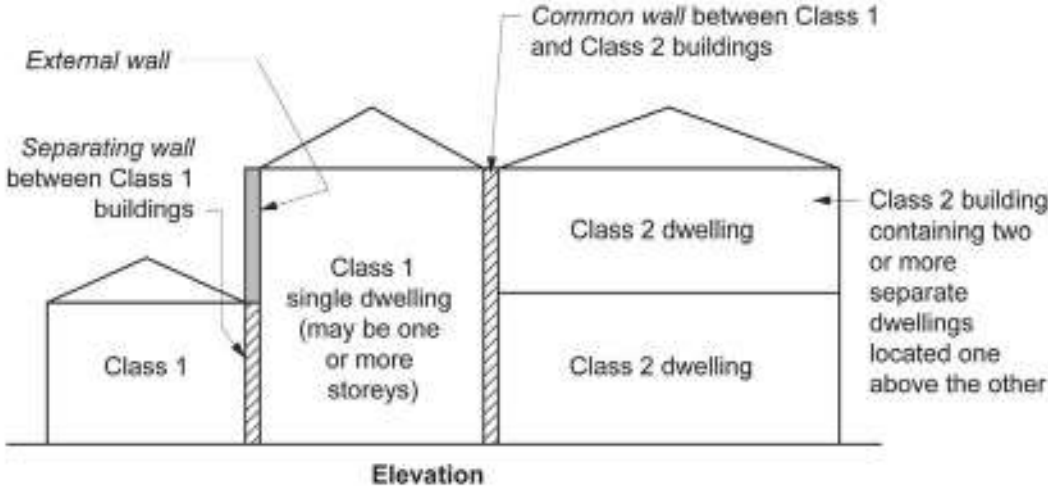

Governing Requirements

Figure 2: Typical Class 1 building configurations

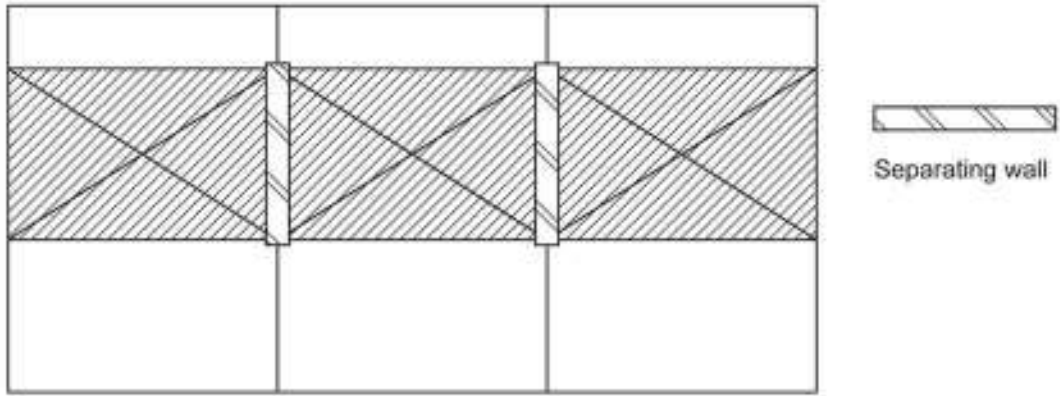

(a) 3 Class 1 buildings
on 3 separate allotments

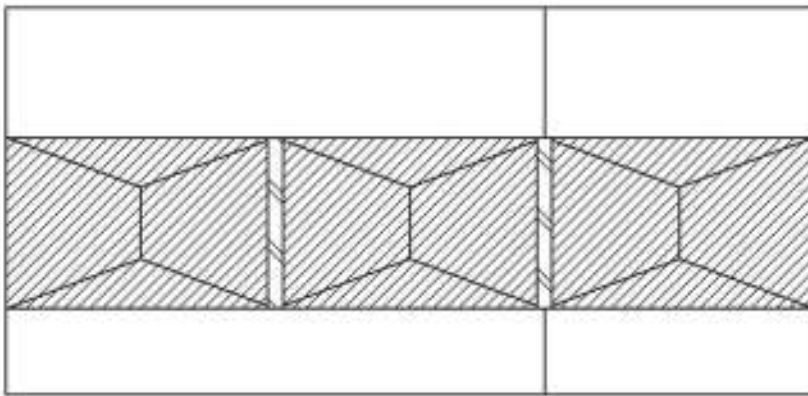

(b) 3 Class 1 buildings
on 2 separate allotments

Plan view

Governing Requirements

Figure 3: Domestic allotment – Classification of buildings and structures

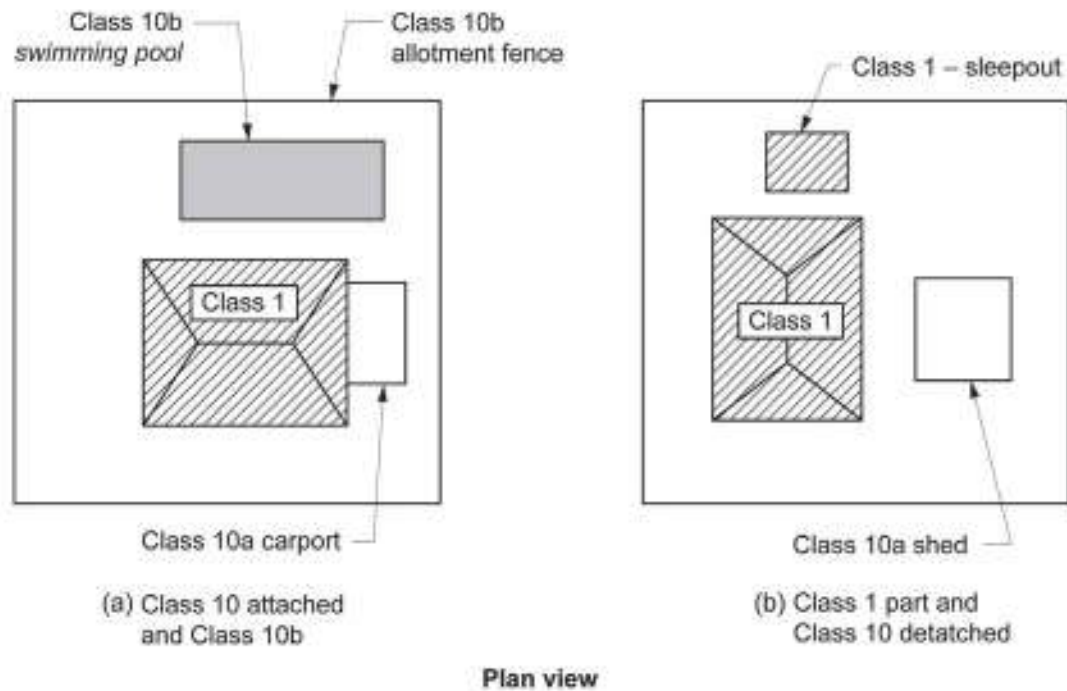

A6.2 Class 2 buildings

- (1) A Class 2 building is a building containing two or more *sole-occupancy units*.
- (2) Each *sole-occupancy unit* in a Class 2 building is a separate dwelling.

A6.3 Class 3 buildings

A Class 3 building is a residential building providing long-term or transient accommodation for a number of unrelated persons, including the following:

- (1) A boarding house, guest house, hostel, lodging house or backpacker accommodation.
- (2) A residential part of a hotel or motel.
- (3) A residential part of a *school*.
- (4) Accommodation for the aged, children, or people with disability.
- (5) A residential part of a *health-care building* which accommodates members of staff.
- (6) A residential part of a *detention centre*.
- (7) A *residential care building*.

Limitation 1:

For [A6.3](#), a Class 3 building is not a Class 1 or 2 residential building. However, a building could be a mixture of Class 3 and another Class.

A6.4 Class 4 buildings

Class 4 is a dwelling in a Class 5, 6, 7, 8 or 9 building.

Application 1:

[A6.4](#) only applies if it is the only dwelling in the building.

A6.5 Class 5 buildings

A Class 5 building is an office building used for professional or commercial purposes.

NSW Class 6

SA Class 6

A6.6 Class 6 buildings

A Class 6 building is a shop or other building used for the sale of goods by retail or the supply of services direct to the public, including—

- (1) an eating room, café, restaurant, milk or soft-drink bar; or
- (2) a dining room, bar area that is not an *assembly building*, shop or kiosk part of a hotel or motel; or
- (3) a hairdresser's or barber's shop, public laundry, or undertaker's establishment; or
- (4) a market or sale room, showroom, or *service station*.

A6.7 Class 7 buildings

A Class 7 building is a storage-type building that includes one or more of the following sub-classifications:

- (1) Class 7a — a *carpark*.
- (2) Class 7b — a building that is used for storage, or display of goods or produce for sale by wholesale.

A6.8 Class 8 buildings

A Class 8 building is a process-type building that includes the following:

- (1) A laboratory.
- (2) A building in which the production, assembling, altering, repairing, packing, finishing, or cleaning of goods or produce for sale takes place.

A6.9 Class 9 buildings

A Class 9 building is a building of a public nature that includes one or more of the following sub-classifications:

- (1) Class 9a — a *health-care building* including any parts of the building set aside as laboratories, and includes a *health-care building* used as a *residential care building*.
- (2) Class 9b — an *assembly building* including a trade workshop or laboratory in a primary or secondary *school*.

Exemption 1:

A6.9(2) excludes any parts of the building that are of another Class.

- (3) Class 9c — a *residential care building*.

A6.10 Class 10 buildings and structures

A Class 10 building includes one or more of the following sub-classifications:

- (1) Class 10a is a non-habitable building including a *private garage*, carport, shed or the like.
- (2) Class 10b is a structure that is a fence, mast, antenna, retaining wall or free-standing wall or *swimming pool* or the like.
- (3) Class 10c is a *private bushfire shelter*.

See [Figure 3](#).

A6.11 Multiple classifications

A building (or part of a building) may be designed, constructed or adapted for multiple purposes and have more than one classification.

Application 1:

For [A6.11](#), a building (or part of a building) must comply with all the relevant requirements that apply to each of the classifications for that building (or part of a building).

Governing Requirements

Explanatory information:

Classification is a process for understanding risks in a building or part, according to its use. It must be correctly undertaken to achieve NCC aims as appropriate to each building in each circumstance.

It is possible for a single building to have parts with different classifications. Part of a building can also have more than one classification. Where there is any conflict between what requirements the part should comply with, the more stringent requirement applies.

Where it is unclear which classification should apply, *appropriate authorities* have the discretion to decide. They base their decision on an assessment of the building proposal.

They will look at what classification the building most closely resembles. They will also take into account the likely *fire load*, plus, the likely consequences of any risks to the safety, health and amenity of people using the building.

Appropriate authorities will also look at any relevant court decisions or determinations of the State or Territory body responsible for considering appeals on building classification matters.

It should be noted that appeals body determinations and, in some States and Territories, certain court decisions are usually not precedent creating. Such decisions are determined on a case-by-case basis.

It should also be noted that State and Territory authorities responsible for building regulatory matters may have issued advice, interpretations or guidelines to assist practitioners in applying the correct classification to a building or part. Advice on such matters should be sought from the relevant authority.

Under [A6.0 Exemption 1](#), if 10% or less of the *floor area* of a *storey* is used for a purpose which could be classified differently to the remainder of that *storey*, that part may be classified as being the same as the remainder. Laboratories and *sole-occupancy units* in Class 2, 3 or 4 parts are excluded from this concession. The reason is that laboratories are considered to have a high *fire hazard* potential and classifying them with the remainder of the building could, in a majority of cases, endanger occupants of the other parts of the building which have a lower *fire hazard* potential. Also, the intent is not to allow *sole-occupancy units* in Class 2, 3 or 4 parts to be regarded as another Class such as Class 6 and then not have any fire or sound insulation between the units and any other classification which may have a high *fire load* and could endanger the occupants of the Class 2, 3 or 4 part.

If [A6.0 Exemption 1](#) is used, it should be remembered that it will still be necessary to use the occupant numbers in Volume One [Table D1.13](#) for the particular use of the area. Likewise, the lighting and equipment levels, people occupancy and load profiles for the area of minor use for the purposes of Volume One [Section J](#) must be in accordance with the use of the area.

If the *storey* has a very large *floor area*, the 10% or less concession area may also be large, even though the rest of the building is classifiable as a building which ordinarily has a lower risk potential. An example of the application of this area concession could be as follows:

- If a single *storey* factory has an office that takes up 8% of the whole *storey's floor area*, the entire building (including the office) can be classified as being Class 8.
- However if that office area takes up 12% of the *storey's floor area*, that area must be classified as Class 5, and the remainder of the building as Class 8.

Under [A6.0\(3\)](#) a plant room, machinery room, lift motor room or *boiler* room, have the same classification as the part of the building they are in. These kinds of rooms do not need to be ancillary or subordinate to the part of the building they are in, that is, the 10% criterion is not applicable.

There are specific provisions for these kinds of rooms. For example, Volume One [Section C](#) requires some of them to be fire separated from the remainder of the building (e.g. see [C2.13](#) with regard to elements of the electricity supply system).

Class 1 buildings are covered in Volumes Two and Three of the NCC. Class 1 buildings are not located above or below another dwelling, or another class of building other than a *private garage*.

A *sole-occupancy unit* used for residential purposes located over another *sole-occupancy unit* used for residential purposes will always be a Class 2 or Class 3 building (depending on the circumstances). It cannot be a Class 1 building.

A single Class 1 dwelling can be made up of more than one building. For example, it may include what is ordinarily called a house, plus one or more habitable 'outbuildings' such as sleepouts. Note that a habitable building such as a sleepout cannot be classified as a Class 10 building.

The height or number of storeys of a Class 1 building makes no difference to its classification.

Class 1b buildings used for short-term holiday accommodation include cabins in caravan parks, tourist parks, farm stay, holiday resorts and similar tourist accommodation. This accommodation itself is typically rented out on a commercial basis for short periods and generally does not require the signing of a lease agreement. Short-term accommodation can also be provided in a boarding house, guest house, hostel, bed and breakfast accommodation or the like.

Governing Requirements

Unlike a Class 1b building described in [A6.1\(2\)\(a\)](#), a Class 1b building described in [A6.1\(2\)\(b\)](#) does not have any *floor area* limitation. Therefore, if 4 or more single dwellings are located on the one allotment and used for short-term holiday accommodation, each single dwelling would be classified as a Class 1b building regardless of the *floor area* of each dwelling or the combined *floor area* of all of the dwellings.

See also Volume One [Table D3.1](#) which contains an explanation of what is considered be “one allotment”.

The Class 1b classification can attract concessions applicable to Class 3 buildings. These concessions allow people to rent out rooms in a house, or run a bed and breakfast, without having to comply with the more stringent Class 3 requirements. The reasoning is that the smaller size of the building and its lower number of occupants represents reduced fire risks.

Apart from their use, the primary difference between Class 1a and Class 1b buildings is that the latter is required to have a greater number of smoke alarms and in some circumstances, access and features for people with a disability.

A Class 2 building is one that includes more than one dwelling, each of which is generally solely occupied by one or more people to the exclusion of others.

Such buildings must not be otherwise classified as a Class 1 or Class 3 building or Class 4 part. See [Figure 4](#) for a typical configuration of Class 1 and Class 2 buildings.

Figure 4: Section showing a typical configuration of Class 1 and Class 2 buildings (with non-combustible roof coverings)

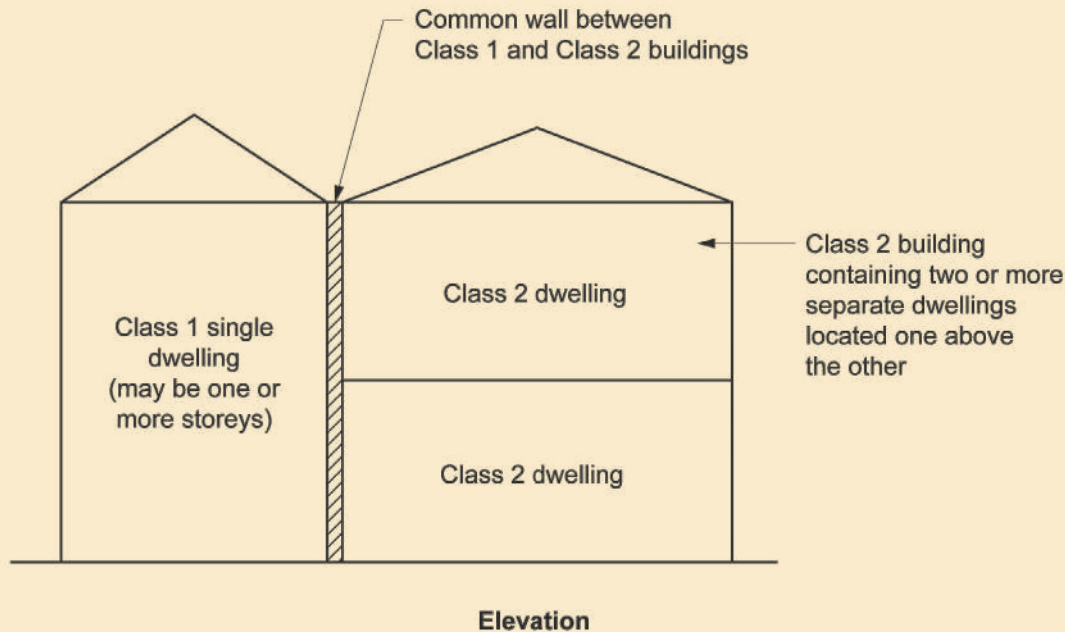

Where a sole-occupancy residential unit is located above another sole-occupancy residential unit, the building containing the units can be either a Class 2 or a Class 3 building, depending on the other circumstances of the building proposal.

Class 2 buildings can be single *storey* attached dwellings. Where there is any common space below such dwellings, they are Class 2 (and cannot be Class 1) irrespective of whether the space below is a *storey* or not (see [Figure 5](#)).

Governing Requirements

Figure 5: Elevation showing a single storey of Class 2 with a common area below

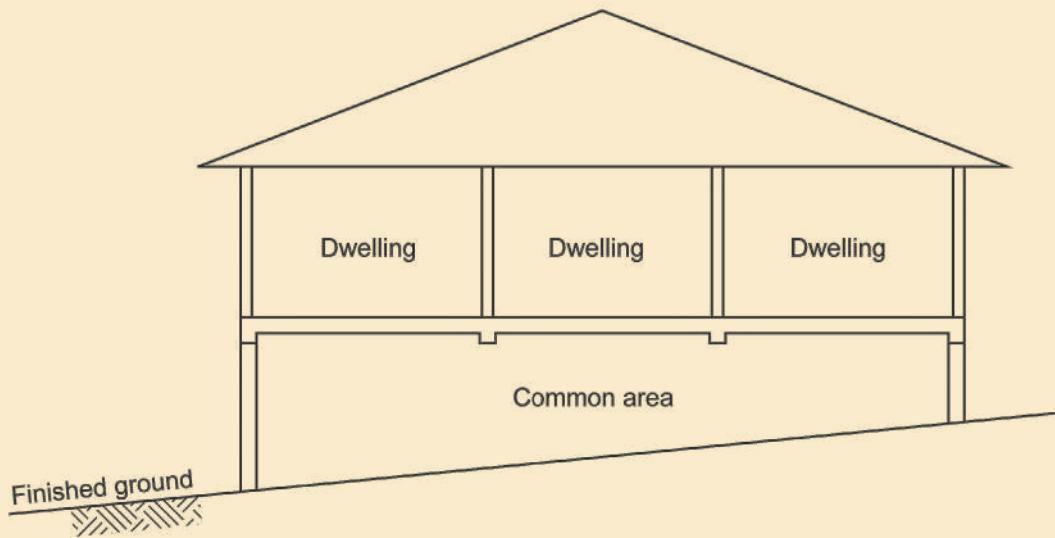

Class 2 buildings can be attached to buildings of another Class. The attached Class 2 buildings need not be attached to one another, and need not be more than a single [storey](#).

When two or more dwellings are attached to another Class, they cannot be Class 4 parts, as any building can only contain one Class 4 dwelling.

Class 3 buildings provide accommodation for unrelated people. The length of stay is unimportant.

Some exceptions to this classification include: certain bed and breakfast accommodation, boarding houses, guest houses, hostels, or lodging houses and the like which fall within the concession provided for Class 1b buildings.

Also, any sized building can be classified as Class 1 or Class 2 if it is used to house any number of unrelated people who jointly own or rent it, or share it on a non-rental basis with an owner or tenant.

It is not unusual for a manager's, owner's or caretaker's dwelling attached to a Class 3 building to be thought of as a Class 4 part of the Class 3 building. However, a Class 4 part of a building can only be part of a Class 5-9 building.

Accordingly, such dwellings are either classified as Class 1, Class 2 or Class 3, depending on the circumstances of the building proposal. However, a building could be a mixture of Class 3 and another Class.

Class 3 buildings include—

- the residential parts of hotels and motels; and
- hotel or motel caretakers', managers' or owners' flats, noting that under certain circumstances such dwellings could be Class 1, Class 2 or Class 3 buildings; and
- dormitory accommodation, in schools or elsewhere, noting that a dormitory is generally (but not always) considered to be a [sole-occupancy unit](#); and
- bed and breakfast accommodation, a boarding house, guest house, hostel, or lodging house; and
- backpackers' accommodation; and
- a building which houses elderly people or other people who require special care. (In some States or Territories it is not acceptable for a Class 1b building to be used to house elderly people or other people who require special care - it is recommended the local building regulatory body be consulted.); and
- workers' quarters, including shearers' or fruit pickers' accommodation, or hotel workers' accommodation.

Class 4 classification applies to some types of accommodation located within a Class 5-9 building. The most common include a caretaker's flat within a building; and accommodation over or otherwise connected to a shop.

A Class 4 part cannot be located within a Class 1, Class 2 or Class 3 building. There can only be one Class 4 dwelling in a building. If there are two or more dwellings, they are Class 1, Class 2, or possibly Class 3. These Class 1, Class 2 or Class 3 parts need not be attached to one another, nor be more than a single [storey](#).

Where a Class 4 part of a building is rented out for accommodation purposes, it retains its Class 4 classification. However, if any other part of the principal building is used for accommodation, for example, the attached shop is converted into an additional flat, both flats become classifiable as Class 2 or, depending on their use, possibly Class 3.

Governing Requirements

Class 5 buildings include professional chambers or suites, lawyers' offices, government offices, advertising agencies and accountants' offices.

A Class 6 building is a building where goods or services are directly sold or supplied to the public. Examples of a Class 6 building may include—

- a place where food or drink may be purchased such as a café or restaurant; or
- a dining room, bar area that is not an *assembly building*, shop or kiosk part of a hotel or motel; or
- a hairdresser's or barber's shop, public laundry, veterinarian; or
- supermarket or sale room, florist, showroom, or *service station*.

Service stations are Class 6 buildings. These are outlets used for the servicing of cars and the selling of fuel or other goods. The expression '*service station*' is not intended to cover buildings where panel beating, auto electrical, muffler replacement, tyre replacement and the like are solely carried out. Such buildings should be classified as Class 6, Class 7 or Class 8 buildings as the *appropriate authority* sees fit.

There are three basic types of Class 7 building. The first is a *carpark* as defined in the NCC. The second is a building used for storage, often referred to as a 'warehouse'. The third is a building used for the display of goods or produce for sale by wholesale. 'Wholesale' means sale to people in the trades or in the business of 'on-selling' goods and services to another party (including the public).

The most common way to describe a Class 8 building is as a 'factory'. However, this can give a simplistic impression of the types of building which can fall within this classification.

For example—

- some laboratories, despite their often small size, have been included as Class 8 buildings principally because of their high *fire hazard*; and
- buildings used for altering or repairing (except *service stations*, which are specifically included in [A6.6](#) as Class 6 buildings); and
- potteries; and
- food manufacturers (but not restaurants, which are specifically included in [A6.6](#) as Class 6 buildings); and
- buildings used for the packing or processing of produce, such as a farm or horticultural building.

Class 9a buildings are *health-care buildings*, including day-care surgeries or procedure units and the like. See definition of *health-care building*. Laboratories that are part of a Class 9a building are Class 9a, despite the general classification of laboratories as Class 8 buildings.

Class 9b buildings are *assembly buildings*. These buildings can include—

- theatres, cinemas and halls, churches, schools, early childhood centres, kindergartens, preschools and child-minding centres; and
- indoor cricket, tennis, basketball centres and sport stadiums; and
- nightclubs, discotheques, bar areas providing live entertainment and/or containing a dance floor, public halls, dance halls and other places of entertainment; and
- snooker halls; and
- bus and railway stations.

Regarding [A6.9\(2\) Exemption 1](#), a building could be a mixture of Class 9b and another Class, or a Class 9b building could contain parts that are of another Class, but be taken as a Class 9b building because of [A6.0 Exemption 1](#).

Class 9c buildings are *residential care buildings* that may contain residents who have various care level needs.

The Class 9c classification recognises that many residents progress through a continuum of care needs from low to high. Many older people enter residential care with low care needs (typically Class 3 facilities) but, as they age, require higher levels of care. In the past, such progression often necessitated the transfer of a hostel resident (Class 3) to a nursing home (Class 9a). This frequently had negative consequences for the health and well-being of the resident, for whom the hostel accommodation was home. It also led, at times, to the separation of couples with differing care needs.

Building designers should note that Class 3 buildings include hostels for the accommodation of the aged, and Class 9a buildings include nursing homes. It is important to be aware, however, that construction of Class 3 or 9a buildings may restrict the options available to the operators of a facility in relation to the profile of the residents they wish to accommodate. Where the potential exists for residents of varying care needs to be accommodated, consideration of the Class 9c provisions may be appropriate. The Class 9c classification allows for any mix of low and high care residents and is intended to allow the mix to change as the residents' care needs change over time, without the need to obtain any further consent or approval from the *appropriate authority*.

Governing Requirements

Multi-care level facilities are for residents who may require the full range of care services outlined by the Aged Care Act. Hence, it is not intended to restrict the resident type and provides maximum flexibility for service providers, residents and the community.

The NCC provisions for Class 9c buildings are based on minimal on duty on-site staff being available at any time. However, it is recognised that the staff numbers vary throughout the course of any one day, due to the care needs of the residents and the functioning of the facility. It is also recognised that the specific care needs of the residents may result in a greater minimum number of staff.

Class 10a buildings are non-habitable buildings. See [Figure 6](#) for an indication of some Class 10 building configurations.

Figure 6: Examples of Class 10 buildings and structures

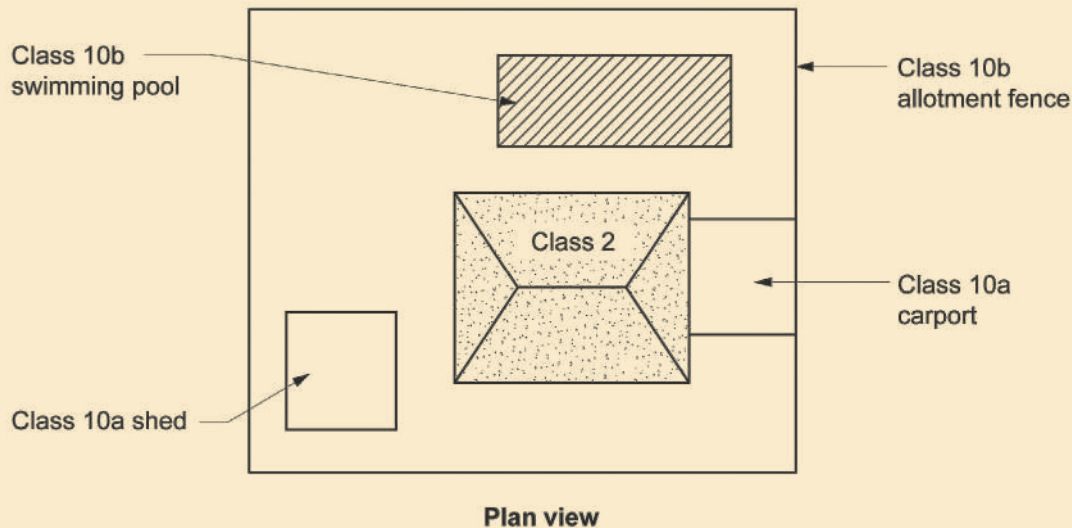

Class 10b structures are non-habitable structures. There is no requirement for Class 10 buildings to be appurtenant to a building of any other Class, for example, a small shed standing on its own on an allotment and a toilet block in a park.

A habitable 'outbuilding' which is appurtenant to another building is generally part of that building. Again, habitable 'outbuildings' cannot be classified as Class 10 buildings.

Typical outbuilding classifications include the following:

- A sleepout on the same allotment as a Class 1 building is part of the Class 1 building.
- A detached entertainment room on the same allotment as a Class 1 building, perhaps associated with a [swimming pool](#), is part of the Class 1 building.
- A small toolshed, used for trade-related hobbies for non-commercial purposes or home repairs, on the same allotment as a Class 1 building, would be classified as a Class 10 building.

Provisions relating to Class 10c structures are only intended to address [private bushfire shelters](#) associated with a single Class 1a dwelling. These provisions are contained in Volume Two of the NCC.

Some States or Territories may exempt some Class 10 buildings or structures (often on the basis of height or size) from the need to have a building permit. Queries on this matter should be referred to the State or Territory body responsible for regulatory matters.

Difficult classifications

Class 2 or Class 3?

There is a fine line between a Class 2 building containing apartments or flats and a Class 3 motel building with units containing bathroom, laundry and cooking facilities, which may both be made available for short term holiday rental. When does a Class 3 motel unit become a Class 2 holiday flat and vice versa?

In general, an assessment will be based on the most likely use of the building by [appropriate authorities](#).

Class 3 buildings, where the occupants are generally unfamiliar with the building and have minimum control over the safety of the building, represent a higher risk level and therefore require higher safety levels. In a case where the classification is unclear, a decision should be made according to the perceived risks inherent in the use of the building.

Class 6 or Class 7?

Governing Requirements

Class 7 buildings include those used to sell goods on the wholesale market, whereas Class 6 buildings are used to sell goods to the public.

Some establishments claim to sell goods to both the wholesale and retail markets. As a rule, however, if the general public has access to the building, it is considered a 'shop', and therefore a Class 6 building.

Hotel bars – Class 6 or 9b

As can be seen from the definition of a Class 6 building, it includes a hotel bar which is not an *assembly building*. The bar includes the bar area and associated standing and seating areas. This clarifies that the bar extends beyond the serving area to include standing and sitting areas where patrons may drink alcohol or other beverages and consume food. The exclusion of an *assembly building* means that a bar providing live entertainment or containing a dance floor is not considered to be Class 6, it must be considered as Class 9b. However, when that use is minor compared with the remainder of the bar, such as a piano bar or the like where patrons only listen to music and there is no dance floor, the *appropriate authority* should exercise judgement on the predominant use and therefore the appropriate classification of the bar.

A Class 9b building is an *assembly building* which is defined to include a building where people may assemble for entertainment, recreational or sporting purposes.

A building may have more than one classification (see A6.11).

Buildings used for farming purposes

Buildings used for *farming*-type purposes are often very diverse in nature, occupancy, use and size. In some States or Territories, *appropriate authorities* may classify *farm buildings* as Class 10a, which covers non-habitable buildings. They would only make this decision if a classification of Class 7 or Class 8 would not be more appropriate.

When making their decision they consider the building's size, purpose, operations and the extent to which people are employed in the building. For example, it may be appropriate to classify a shed which is used to store a tractor as a Class 10a building.

The NCC has definitions of "*farm building*" and "*farm shed*" which are certain Class 7 and 8 buildings used for *farming* purposes. Concessions to specific *Deemed-to-Satisfy Provisions* apply to *farm buildings* and *farm sheds* in recognition of their often low risk features, and it is recommended that reference is made to the definitions of "*farm building*" and "*farm shed*" for further guidance which may assist determination of an appropriate NCC classification.

For example, if people are likely to be employed to stack materials/produce in a storage building or remove materials/produce from a storage building then a classification of Class 7b may be appropriate. Depending upon whether the criteria in the definition of *farm shed* or *farm building* have been met, the associated *Deemed-to-Satisfy Provisions* in NCC Volume One Part H3 may apply.

Similarly if people are likely to be employed to pack or process materials/produce within a building, or employed to feed, clean or collect produce from animals or plants within a building then a classification of Class 8 may be appropriate. Depending upon whether the criteria in the definition of *farm shed* or *farm building* have been met, the associated *Deemed-to-Satisfy Provisions* in NCC Volume One Part H3 may apply.

However identification of low *fire load*, low occupant risk and low risk of fire spread should not be used as justification for choosing a less stringent building classification for a building under the *Deemed-to-Satisfy Provisions*. For example, if the intended use of a building is to grow or store a large amount of tomatoes, such as a large greenhouse, and there is likely to be only one to two persons in the building at any time, it is considered inappropriate to classify the building as a Class 10a under the *Deemed-to-Satisfy Provisions* and a classification of Class 7 or Class 8 would be more appropriate.

The *Deemed-to-Satisfy Provisions* for a Class 7 or Class 8 *farm building* or *farm shed* do not prevent the ability to consider or develop a *Performance Solution* for a particular building where the requirements may not be considered appropriate or are viewed as too stringent. Similarly if a Class 7 or 8 building used for *farming* purposes does not meet all the criteria to be considered a *farm building* or *farm shed* under the *Deemed-to-Satisfy Provisions*, this would not limit the ability to develop a *Performance Solution* which could contain features similar to those allowed under the *Deemed-to-Satisfy Provisions* for *farm buildings* or *farm sheds*.

For example, if a Class 8 commercial poultry building meets all the criteria to be considered a *farm building* under the *Deemed-to-Satisfy Provisions* other than the maximum *floor area* criteria, a *Performance Solution* could be developed to demonstrate that the concessions for a *farm building* under the *Deemed-to-Satisfy Provisions* are appropriate.

In regards to a *farm building* or *farm shed* where the purpose of the building is to park *farm vehicles* when not in use, as well as perhaps clean or polish the vehicle(s), it may be appropriate that this type of building is classified as a Class 7a.

However, a number of *farm buildings* and *farm sheds* are often not only used for the storage of *farm vehicles*, but to store supplies such as fuel, grain or hay. A Class 7a classification may still be appropriate where the majority of the shed's space is intended to be designated for the parking of vehicles. However, it may be more appropriate to classify

Governing Requirements

some types of buildings as Class 7b, rather than Class 7a where a mixed use shed is intended.

Under [A6.11](#) each part of a building (including the entire building) may have more than one classification. This means, for example, that it is permissible to classify part of a building as a Class 6/7 building, or a Class 5/6 building, or whatever is appropriate.

It is expected that this approach may be taken by a builder who is uncertain of what the precise use of a building will be after its sale, or to maximise the flexibility of the building's use.

Under [A6.11 Application 1](#) where a building has more than one classification the more stringent Class requirements will apply.

Performance Provisions

- Part 2.0** **Application**
- Part 2.1** **Structure**
- Part 2.2** **Damp and weatherproofing**
- Part 2.3** **Fire safety**
- Part 2.4** **Health and amenity**
- Part 2.5** **Safe movement and access**
- Part 2.6** **Energy efficiency**
- Part 2.7** **Ancillary provisions and additional construction requirements**

Section 2 Performance Provisions

Part 2.0 Application

2.0.1 Application

Part 2.1 Structure

Performance Requirements

P2.1.1 Structural stability and resistance

P2.1.2 Buildings in flood areas

Verification Methods

V2.1.1 Structural reliability

V2.1.2 Structural robustness

Part 2.2 Damp and weatherproofing

Performance Requirements

P2.2.1 Rainwater management

P2.2.2 Weatherproofing

P2.2.3 Rising damp

P2.2.4 Drainage from swimming pools

Verification Methods

V2.2.1 Weatherproofing

Part 2.3 Fire safety

Performance Requirements

P2.3.1 Spread of fire

P2.3.2 Automatic warning for occupants

Verification Methods

V2.3.1.1 Avoidance of the spread of fire [P2.3.1(a)(i)]

V2.3.1.2 Avoidance of the spread of fire [P2.3.1(a)(ii)]

V2.3.1.3 Avoidance of the spread of fire [P2.3.1(b)] (adjoining allotment)

V2.3.1.4 Avoidance of the spread of fire [P2.3.1(b)] (same allotment)

Part 2.4 Health and amenity

Performance Requirements

P2.4.1 Wet areas

P2.4.2 Room heights

P2.4.3 Personal hygiene and other facilities

P2.4.4 Lighting

P2.4.5 Ventilation

P2.4.6 Sound insulation

P2.4.7 Condensation and water vapour management

Verification Methods

V2.4.2 Room or space height

V2.4.4 Verification of suitable natural light

V2.4.5 Verification of suitable indoor air quality

V2.4.6 Sound insulation

V2.4.7 Verification of condensation management

Part 2.5 Safe movement and access

Performance Requirements

P2.5.1 Movement to and within a building

P2.5.2 Fall prevention barriers

Verification Methods

V2.5.1 Wire barriers

Part 2.6 Energy efficiency

Performance Requirements

P2.6.1 Building

P2.6.2 Services

Verification Methods

V2.6.1 Application of this Part

V2.6.2 * * * * *

V2.6.2.1 * * * * *

V2.6.2.2 Verification using a reference building

V2.6.2.3 Verification of building envelope sealing

V2.6.3 * * * * *

Part 2.7 Ancillary provisions and additional construction requirements

Performance Requirements

P2.7.1 Swimming pool access

P2.7.2 Swimming pool recirculation systems

P2.7.3 Heating appliances

P2.7.4 Buildings in alpine areas

P2.7.5 Buildings in bushfire prone areas

P2.7.6 Private bushfire shelters

Verification Methods

V2.7.1 Combustion appliances

V2.7.2 Buildings in bushfire prone areas

Part 2.0 Application

2.0.1 Application

- (a) This Section contains the [Performance Requirements](#) for Class 1 and 10 buildings (other than access requirements for people with disabilities in Class 1b and 10 buildings).
- (b) For the purposes of this Section a reference to a building includes a reference to both Class 1 and 10 buildings unless otherwise specified.

Note:

Access requirements for people with disabilities in Class 10 buildings are contained in [Part D3](#) of NCC Volume One.

Part 2.1 Structure

Explanatory information:

Objective

O2.1

The Objective is to—

- (a) safeguard people from injury caused by structural failure; and
- (b) safeguard people from loss of amenity caused by structural behaviour; and
- (c) protect *other property* from physical damage caused by structural failure; and
- (d) safeguard people from injury that may be caused by failure of, or impact with, glazing.

Functional statements

F2.1

- (a) A building or structure is to withstand the combination of loads and other actions to which it may be reasonably subjected.
- (b) Glazing is to be installed in a building to avoid undue risk of injury to people.

Performance Requirements

P2.1.1 Structural stability and resistance

- (a) A building or structure, during construction and use, with appropriate degrees of reliability, must—
 - (i) perform adequately under all reasonably expected design actions; and
 - (ii) withstand extreme or frequently repeated design actions; and
 - (iii) be designed to sustain local damage, with the structural system as a whole remaining stable and not being damaged to an extent disproportionate to the original local damage; and
 - (iv) avoid causing damage to *other properties*,
by resisting the actions to which it may reasonably be expected to be subjected.
- (b) The actions to be considered to satisfy (a) include but are not limited to—
 - (i) permanent actions (dead loads); and
 - (ii) imposed actions (live loads arising from occupancy and use); and
 - (iii) wind action; and
 - (iv) earthquake action; and
 - (v) snow action; and
 - (vi) liquid pressure action; and
 - (vii) ground water action; and
 - (viii) rainwater action (including ponding action); and
 - (ix) earth pressure action; and
 - (x) differential movement; and
 - (xi) time dependent effects (including creep and shrinkage); and
 - (xii) thermal effects; and
 - (xiii) ground movement caused by—
 - (A) swelling, shrinkage or freezing of the subsoil; and
 - (B) landslip or subsidence; and
 - (C) siteworks associated with the building or structure; and

Performance Provisions

- (xiv) *construction activity actions*; and
 - (xv) termite actions.
- (c) The structural resistance of materials and forms of construction must be determined using five percentile characteristic material properties with appropriate allowance for—
- (i) known construction activities; and
 - (ii) type of material; and
 - (iii) characteristics of the site; and
 - (iv) the degree of accuracy inherent in the methods used to assess the structural behaviour; and
 - (v) action effects arising from the differential settlement of foundations, and from restrained dimensional changes due to temperature, moisture, shrinkage, creep and similar effects.
- (d) Glass installations that are at risk of being subjected to human impact must have glazing that—
- (i) if broken on impact, will break in a way that is not likely to cause injury to people; and
 - (ii) resists a reasonably foreseeable human impact without breaking; and
 - (iii) is protected or marked in a way that will reduce the likelihood of human impact.

P2.1.2 Buildings in flood areas

- (a) A building in a *flood hazard area* must be designed and constructed, to the degree necessary, to resist flotation, collapse or significant permanent movement resulting from the action of hydrostatic, hydrodynamic, erosion and scour, wind and other actions during the *defined flood event*.
- (b) The actions and requirements to be considered to satisfy (a) include but are not limited to—
- (i) flood actions; and
 - (ii) elevation requirements; and
 - (iii) foundation and footing requirements; and
 - (iv) requirements for enclosures below the *flood hazard level*; and
 - (v) requirements for structural connections; and
 - (vi) material requirements; and
 - (vii) requirements for utilities; and
 - (viii) requirements for occupant egress.

Limitation:

P2.1.2 only applies to a Class 1 building.

State and Territory Variations

P2.1.2 does not apply in Queensland.

Note: Building work in designated *flood hazard areas* is regulated by the Building Act 1975 and Development Code 3.5 - Construction of buildings in flood hazard areas.

In Queensland after P2.1.2 insert QLD P2.1.3 as follows:

QLD P2.1.3

- (a) The risk of *primary building elements* in a Class 1 or 10 building being damaged by subterranean termites must be adequately minimised by the use of a suitable termite management measure that—
- (i) if it serves a non-temporary Class 1 building, has a design life of at least 50 years; or
 - (ii) if it serves a building not specified in (i), has a design life of at least 50 years or the specified design life of the building, whichever is the lesser; or
 - (iii) is easily and readily accessible for replenishment or replacement and is capable of being replenished or replaced.
- (b) A termite management measure *required* by (a), to the degree necessary, must—
- (i) be accessible to enable the installation, maintenance and inspection of the termite management measure to

Performance Provisions

- be carried out; and
- (ii) incorporate suitable measures to adequately minimise the risk of the termite management measure inadvertently being damaged, bridged or breached.

Explanatory information:

QLD P2.1.3(a) requires a termite management measure in Queensland to have a design life of at least 50 years unless it is easily and readily accessible for replenishment or replacement and is capable of being replenished or replaced. In recognition that some buildings other than non-temporary Class 1 buildings may be designed to last less than 50 years, the option of the termite management measure having a design life at least equal to that specified for the building is given. If this option is used, the design life of the building should be agreed upon by all relevant stakeholders at the design stage and should form part of the documentation kept by the *appropriate authority*. It should not be assumed that the design life of 50 years in QLD P2.1.3(a)(i) and (ii) applies to any other provisions of the BCA, unless stated.

An example of a termite management measure that may satisfy QLD P2.1.3(a)(iii) is a chemical reticulation system beneath a concrete floor slab laid directly on the ground, provided that the system is easily and readily accessible for replenishment and is capable of being replenished.

An example of a termite management measure that may not satisfy QLD P2.1.3(a) for a non-temporary Class 1 building is a hand-sprayed chemical beneath a concrete floor slab laid directly on the ground if the chemical does not have a design life of at least 50 years. The concrete floor slab being laid directly on the ground would prevent the area beneath the slab from being easily and readily accessible for replenishment or replacement of the termite management measure.

An example of a termite management measure being inadvertently bridged or breached is when a person places a garden or mulch over the top of or above the level of a termite management measure enabling termites to bypass the measure.

P2.1.2 does not apply in South Australia.

Verification Methods

V2.1.1 Structural reliability

- (a) This *Verification Method* is only applicable to components with a resistance coefficient of variation of at least 10% and not more than 40%. For components with a calculated value less than 10%, then a minimum value of 10% should be used.
- (b) Compliance with P2.1.1(a), (b) and (c) is verified for the design of a structural component for strength when—
- (i) the capacity reduction factor ϕ satisfies—
- $$\phi \leq \text{Average} (\phi_G, \phi_Q, \phi_W, \dots),$$
- where—
- $\phi_G, \phi_Q, \phi_W, \dots$ are capacity reduction factors for all relevant actions and must contain at least permanent (G), imposed (Q) and wind (W) actions; and
- (ii) the capacity reduction factors $\phi_G, \phi_Q, \phi_W, \dots$ are calculated for target reliability indices for permanent action β_{TG} , for imposed action β_{TQ} , for wind action β_{TW} , ... in accordance with the Equation 1—

Equation 1

$$\beta = \ln \left[\left(\frac{\bar{R}}{\bar{S}} \right) \sqrt{\frac{C_S}{C_R}} \right] / \sqrt{\ln(C_R \cdot C_S)}$$

where—

Performance Provisions

$$\left(\frac{\bar{R}}{\bar{S}}\right) = \frac{\left(\frac{\gamma}{\phi}\right)}{\left(\frac{\bar{S}}{S_N}\right)} \left(\frac{\bar{R}}{R_N}\right)$$

$$C_R = 1 + V_R^2$$

$$C_S = 1 + V_S^2$$

where—

$\frac{\bar{R}}{R_N}$ = ratio of mean resistance to nominal; and

$\frac{\bar{S}}{S_N}$ = ratio of mean action to nominal; and

C_S = correction factor for action; and

C_R = correction factor for resistance; and

V_S = coefficient of variation of the appropriate action as given in [Table V2.1.1a](#); and

V_R = coefficient of variation of the resistance; and

γ = appropriate load factor for the action as given in AS/NZS 1170.0; and

ϕ = capacity factor for the appropriate action; and

Table V2.1.1a - Annual action models

Design Action	Ratio of mean action to nominal	Coefficient of variation of the action
Permanent Action ($Y_G = 1.35$)	$(\bar{G}/G_N) = 1.00$	$V_G = 0.10$
Imposed Action ($Y_Q = 1.50$)	$(\bar{Q}/Q_N) = 0.50$	$V_Q = 0.43$
Wind Action ($Y_W = 1.00$)(Non-cyclonic)	$(\bar{W}/W_N) = 0.33$	$V_W = 0.49$
Wind Action ($Y_W = 1.00$)(Cyclonic)	$(\bar{W}/W_N) = 0.16$	$V_W = 0.71$
Snow Action ($Y_S = 1.00$)	$(\bar{S}/S_N) = 0.29$	$V_S = 0.57$
Earthquake Action ($Y_E = 1.00$)	$(\bar{E}/E_N) = 0.05$	$V_E = 1.98$

(iii) the annual target reliability indices β_{TG} , β_{TQ} , β_{TW} ,... are established as follows:

- (A) For situations where it is appropriate to compare with an *equivalent* Deemed-to-Satisfy product, a resistance model must be established for the *equivalent* Deemed-to-Satisfy product and β_{TG} , β_{TQ} , β_{TW} must be calculated for the *equivalent* Deemed-to-Satisfy product in accordance with [Equation 1](#). The target reliability indices β_{TG} , β_{TQ} , β_{TW} ,... thus established, must not be less than those given in [Table V2.1.1b](#) minus 0.5.

Performance Provisions

- (B) For situations where it is not appropriate to compare with an *equivalent* Deemed-to-Satisfy product, the target reliability index β must be as given in [Table V2.1.1b](#).

Table V2.1.1b - Annual target reliability indices (β)

Type of action	Target reliability index β
Permanent action	4.3
Imposed action	4.0
Wind, snow and earthquake action	3.7

Application of [Table V2.1.1b](#):

1. [Table V2.1.1b](#) is applicable for components that exhibit brittle failure similar to concrete as specified in AS 3600.
 2. For components with creep characteristics similar to timber as specified in AS 1720.1, the target reliability index for permanent action must be increased to 5.0.
 3. The above target reliability indices are based on materials or systems that exhibit creep or brittle failure characteristics similar to timber and concrete. [Table V2.1.1b](#) may also be applicable to materials or systems that exhibit creep or brittle failure differently to steel, timber or concrete provided that the creep and/or brittle nature of the material or system are properly accounted for in the design model.
 4. The above target reliability indices are also applicable for materials or systems that exhibit ductile failure characteristics.
- (c) The resistance model for the component must be established by taking into account variability due to material properties, fabrication and construction processes, and structural modelling.

V2.1.2 Structural robustness

Compliance with [P2.1.1\(a\)\(iii\)](#) is verified for structural robustness by—

- (a) assessment of the structure such that upon the notional removal in isolation of—
- (i) any supporting column; or
 - (ii) any beam supporting one or more columns; or
 - (iii) any segment of a load bearing wall of length equal to the height of the wall, the building remains stable and the resulting collapse does not extend further than the immediate adjacent storeys; and
- (b) demonstrating that if a supporting structural component is relied upon to carry more than 25% of the total structure, a systematic risk assessment of the building is undertaken and critical high risk components are identified and designed to cope with the identified hazard or protective measures chosen to minimise the risk.

Explanatory information:

[V2.1.2](#) is a means to verify structural robustness of a building or structure in order to meet the requirements of [P2.1.1\(a\)\(iii\)](#). For further guidance, refer to ABCB Handbook for Structural Robustness.

Part 2.2 Damp and weatherproofing

Explanatory information:

Objective

O2.2

The Objective is to—

- (a) safeguard occupants from illness or injury and protect the building from damage caused by—
 - (i) *surface water*; and
 - (ii) external moisture entering a building; and
 - (iii) the accumulation of internal moisture in a building; and
 - (iv) discharge of *swimming pool* waste water; and
- (b) protect *other property* from damage caused by—
 - (i) redirected *surface water*; and
 - (ii) the discharge of *swimming pool* waste water.

Functional statements

F2.2.1 Surface water

A building including any associated *sitework* is to be constructed in a way that protects people and *other property* from the adverse effects of redirected *surface water*.

F2.2.2 Weatherproofing and dampness

A building is to be constructed to provide resistance to moisture from the outside and moisture rising from the ground.

Limitation:

F2.2.2 does not apply to a Class 10 building except where its construction contributes to the weatherproofing of the Class 1 building.

F2.2.3 Drainage from swimming pools

Adequate means for the disposal of *swimming pool* water and drainage is to be provided to a *swimming pool*.

Performance Requirements

P2.2.1 Rainwater management

- (a) *Surface water*, resulting from a storm having an *average recurrence interval* of 20 years and which is collected or concentrated by a building or *sitework*, must be disposed of in a way that avoids the likelihood of damage or nuisance to any *other property*.
- (b) *Surface water*, resulting from a storm having an *average recurrence interval* of 100 years must not enter the building.

Limitation:

P2.2.1(b) does not apply to a Class 10 building where in the particular case there is no necessity for compliance.

- (c) A drainage system for the disposal of *surface water* resulting from a storm having an *average recurrence interval* of—
 - (i) 20 years must—
 - (A) convey *surface water* to an appropriate *outfall*; and
 - (B) avoid *surface water* damaging the building; and
 - (ii) 100 years must avoid the entry of *surface water* into a building.

P2.2.2 Weatherproofing

A roof and *external wall* (including openings around *windows* and doors) must prevent the penetration of water that could cause—

- (a) unhealthy or dangerous conditions, or loss of amenity for occupants; and

Performance Provisions

- (b) undue dampness or deterioration of building elements.

Limitation:

[P2.2.2\(a\)](#) does not apply to a Class 10 building except where its construction contributes to the weatherproofing of the Class 1 building.

P2.2.3 Rising damp

Moisture from the ground must be prevented from causing—

- (a) unhealthy or dangerous conditions, or loss of amenity for occupants; and
 (b) undue dampness or deterioration of building elements.

Limitation:

[P2.2.3](#) does not apply to a Class 10 building where in the particular case there is no necessity for compliance.

State and Territory Variations

In South Australia delete P2.2.3 and insert SA P2.2.3 as follows:

SA P2.2.3 Rising damp

- (a) Moisture from the ground must be prevented from causing—
- (i) undue dampness or deterioration of building elements; and
 - (ii) unhealthy or dangerous conditions, or loss of amenity for occupants.
- (b) Barriers installed to prevent transfer of moisture from the ground must have—
- (i) high resistance to moisture penetration; and
 - (ii) high resistance to damage during construction; and
 - (iii) high resistance to degradation by dissolved salts.

In New South Wales delete P2.2.3 and insert NSW P2.2.3 as follows:

NSW P2.2.3 Rising damp

- (a) Moisture from the ground must be prevented from causing—
- (i) unhealthy or dangerous conditions, or loss of amenity for occupants; and
 - (ii) undue dampness or deterioration of building elements.
- (b) Barriers installed beneath slab on ground construction for the purposes of (a) must have a high resistance to damage during construction.

Limitation:

[P2.2.3](#) does not apply to a Class 10 building where in the particular case there is no necessity for compliance.

Explanatory information:

The intent of requiring the barrier to have a high resistance to damage during construction is to increase the barrier's ability to resist punctures during construction. By being less susceptible to puncturing, the barrier will provide increased protection against moisture containing dissolved salts from coming into contact with the concrete slab.

P2.2.4 Drainage from swimming pools

A *swimming pool* must have adequate means of draining the pool in a manner which will not—

- (a) cause illness to people; or
 (b) affect *other property*.

Note:

The *Housing Provisions* do not contain any *Deemed-to-Satisfy Provisions* for this *Performance Requirement*.

State and Territory Variations

[P2.2.4](#) does not apply in the Northern Territory.

Performance Provisions

Verification Methods

V2.2.1 Weatherproofing

- (a) Compliance with P2.2.2 for the weatherproofing of an *external wall* that—
 - (i) has a risk score of 20 or less, when the sum of all risk factor scores are determined in accordance with Table V2.2.1a; and
 - (ii) is not subjected to an ultimate limit state wind pressure of more than 2.5 kPa; and
 - (iii) includes only windows that comply with AS 2047,
is verified when a prototype passes the procedure described below:
 - (iv) The test specimen is in accordance with the requirements of (b).
 - (v) The test procedure is in accordance with the requirements of (c).
 - (vi) The test specimen does not fail the criteria in (d).
 - (vii) The test is recorded in accordance with the requirements of (e).

Table V2.2.1a – Risk factors and scores

Risk factor	Category	Risk severity	Score
Wind region	Region A (AS/NZS 1170.2)	Low to medium	0
	Region B (AS/NZS 1170.2)		
	Region C (AS/NZS 1170.2)	High	1
	Region D (AS/NZS 1170.2)	Very high	2
Number of storeys	One storey	Low	0
	Two storeys in part	Medium	1
	Two storeys	High	2
	More than two storeys	Very high	4
Roof/wall junctions	Roof-to-wall junctions fully protected	Low	0
	Roof-to-wall junctions partially exposed	Medium	1
	Roof-to-wall junctions fully exposed	High	3
	Roof elements finishing within the boundaries formed by the <i>external walls</i>	Very high	5
Eaves width	Greater than 600 mm for single storey	Low	0
	451-600 mm for single storey; or greater than 600 mm for two storey	Medium	1
	101-450 mm for single storey; or 451-600 mm for two storey; or greater than 600 mm for above two storey	High	2
	0-100 mm for single storey; or 0-450 mm for two storey; or less than 600 mm for above two storey	Very high	5
Envelope complexity	Simple shape with single cladding type	Low	0
	Complex shape with no more than two cladding types	Medium	1
	Complex shape with more than two cladding types	High	3
	As for high risk but with fully exposed roof-to-wall junctions	Very high	6
Decks, porches and balconies	None; or timber slat deck or porch at ground level	Low	0
	Fully covered in plan view by roof; or timber slat deck attached at first or second floor level	Medium	2
	Balcony exposed in plan view at first floor level; or balcony cantilevered at first floor level	High	4
	Balcony exposed in plan view at second floor level or above; or	Very high	6

Performance Provisions

Risk factor	Category	Risk severity	Score
	balcony cantilevered at second floor level or above		

Notes to Table V2.2.1a:

1. Eaves width is measured horizontally from the external face of any wall cladding to the outer edge of any overhang, including fascia and external gutters.
2. Barriers to prevent falling and parapets are considered as 0 mm eaves.

(b) Test specimen

The test specimen must incorporate—

- (i) representative samples of openings and joints, including—
 - (A) vertical and horizontal control joints; and
 - (B) wall junctions; and
 - (C) *windows* or doors; and
 - (D) electrical boxes; and
 - (E) balcony drainage and parapet flashings; and
 - (F) footer and header termination systems; and
- (ii) for a *cavity wall*—
 - (A) a transparent material for a proportion of the internal wall lining (to provide an unobstructed view of the *external wall* cladding) with sufficient structural capability and similar air tightness to resist the applied wind pressures; and
 - (B) a 15 mm diameter hole in the internal wall lining below a *window*.

(c) Test procedure

- (i) The test procedure for a *direct fix cladding wall* or *unique wall* must be as follows:
 - (A) Apply 100% positive and negative serviceability wind pressures to the external face of the test specimen for a period of not less than 1 minute each.
 - (B) Apply static pressure of either 300 Pa or 30% serviceability wind pressure, whichever is higher, in accordance with the water penetration test procedure at clause 8.5.2 of AS/NZS 4284.
 - (C) Apply cyclic pressure in accordance with—
 - (aa) the three stages of Table V2.2.1b; and
 - (bb) the water penetration test procedure at clause 8.6.2 of AS/NZS 4284.

Table V2.2.1b

Stage number	Serviceability wind pressure
1	15% to 30%
2	20% to 40%
3	30% to 60%

- (ii) The test procedure for a *cavity wall* must be as follows:
 - (A) Apply 100% positive and negative serviceability wind pressures to the external face of the test specimen for a period of not less than 1 minute each.
 - (B) Apply static pressure of either 300 Pa or 30% serviceability wind pressure, whichever is higher, in accordance with the water penetration test procedure at clause 8.5.2 of AS/NZS 4284.
 - (C) Apply cyclic pressure in accordance with—
 - (aa) stage 3 of Table V2.2.1b; and
 - (bb) the water penetration test procedure at clause 8.6.2 of AS/NZS 4284.
 - (D) To simulate the failure of the primary weather-defence or sealing, the following procedure must be applied to the test specimen:

Performance Provisions

- (aa) Insert 6 mm diameter holes through the external face of the *cavity wall* in all places specified below:
 - (AA) Wall/window or wall/door junctions at $\frac{3}{4}$ height.
 - (BB) Immediately above the head flashing.
 - (CC) Through external sealing of the horizontal and vertical joints.
 - (DD) Above any other penetration detail not covered by (AA) to (CC).
- (bb) Repeat the static and cyclic pressure tests of (B) and (C).
- (cc) Within 30 minutes of the completion of (bb), remove the internal lining of the *cavity wall* and check for compliance with (d).
- (dd) With the internal lining removed, apply a final static pressure test at 50 Pa for a period of 15 minutes.

(d) Compliance

- (i) A *direct fix cladding wall* and *unique wall* are verified for compliance with P2.2.2 if there is no presence of water on the inside surface of the facade.
- (ii) A *cavity wall* is verified for compliance with P2.2.2 if there is no presence of water on the removed surface of the cavity, except that during the simulation of the failure of the primary weather-defence or sealing, water may—
 - (A) transfer to the removed surface of the cavity due to the introduced defects (6 mm holes); and
 - (B) contact, but not pool on, battens and other cavity surfaces.

(e) Test report

The test report must include the following information:

- (i) Name and address of the person supervising the test.
- (ii) Test report number.
- (iii) Date of the test.
- (iv) Cladding manufacturer's name and address.
- (v) Construction details of the test specimen, including a description, and drawings and details of the components, showing modifications, if any.
- (vi) Test sequence with the pressures used in all tests.
- (vii) For each of the static and cyclic pressure tests, full details of all leakages, including position, extent and timing.

Explanatory information:

Verification Method V2.2.1 contains the same test procedures, compliance criteria and reporting of test results that are contained in *Verification Method FV1*, Volume One of the BCA. Consequently, the Guide to Volume One of the BCA contains detailed and supportive explanatory information that is also relevant to V2.2.1.

Part 2.3 Fire safety

Explanatory information:

Objective

O2.3

The Objective is to—

- (a) safeguard the occupants from illness or injury by alerting them of a fire in the building so that they may safely evacuate; and
- (b) avoid the spread of fire.

Functional statements

F2.3.1 Protection from the spread of fire

A Class 1 building is to be protected from the spread of fire.

F2.3.2 Fire detection and early warning

A Class 1 building is to be provided with safeguards so that occupants are warned of a fire in the building so that they may safely evacuate.

Performance Requirements

P2.3.1 Spread of fire

- (a) A Class 1 building must be protected from the spread of fire from—
 - (i) another building other than an associated Class 10 building; and
 - (ii) the allotment boundary, other than a boundary adjoining a road or public space.
(see [Figure 2.3.1](#))
- (b) A Class 10a building must not significantly increase the risk of fire spread between Class 2 to 9 buildings.

State and Territory Variations

In South Australia after P2.3.1(a)(i) delete P2.3.1(a)(ii) and insert SA P2.3.1(a)(ii) and (iii) as follows:

- (a)
 - (ii) the allotment boundary, other than a boundary adjoining a road or public space; and
 - (iii) a Class 10b *brush fence*.

Figure 2.3.1 Typical areas of potential fire spread

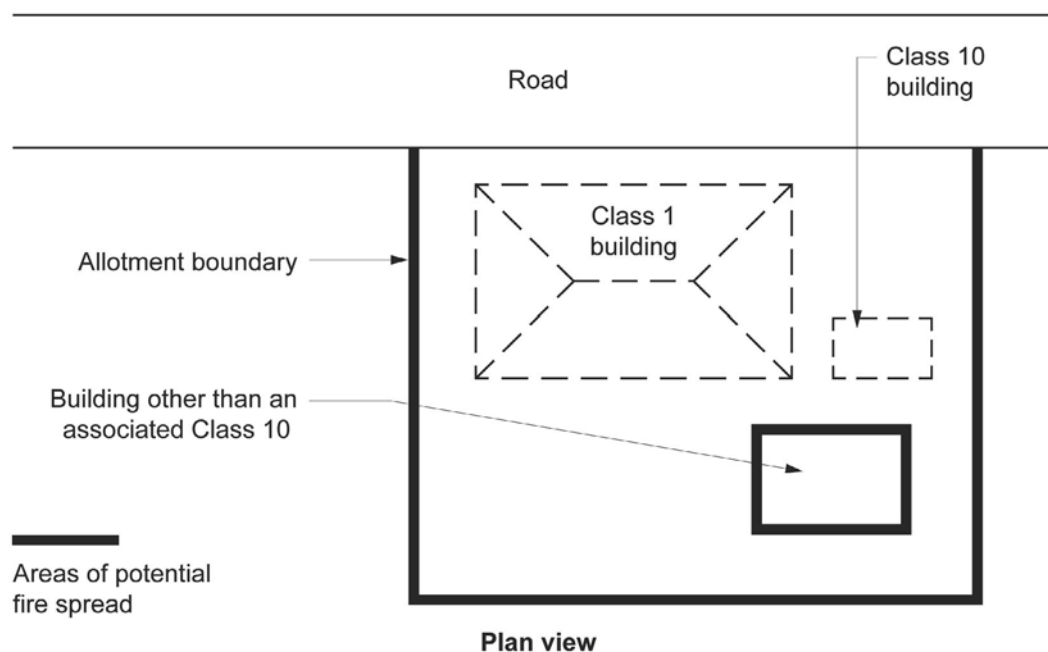

Note to Figure 2.3.1: This diagram indicates areas of potential fire spread. This situation will differ for corner allotments, etc.

P2.3.2 Automatic warning for occupants

In a Class 1 building, occupants must be provided with *automatic* warning on the detection of smoke so that they may evacuate in the event of a fire to a place of safety.

Verification Methods

V2.3.1.1 Avoidance of the spread of fire [P2.3.1(a)(i)]

Compliance with P2.3.1(a)(i) to avoid the spread of fire between buildings on the same allotment is verified when—

- the *external walls* and any openings in the *external walls* of a building, less than 1.8 m from another building, are capable of withstanding 92.6 kW/m² of heat flux for 60 minutes; and
- the *external walls* extend to the underside of a *non-combustible* roof covering or *non-combustible* eaves lining in accordance with 3.7.2.4.

V2.3.1.2 Avoidance of the spread of fire [P2.3.1(a)(ii)]

Compliance with P2.3.1(a)(ii) to avoid the spread of fire from an allotment boundary is verified when—

- the *external walls* and any openings in the *external walls* of a building, less than 0.9 m from an allotment boundary, are capable of withstanding 92.6 kW/m² of heat flux for 60 minutes; and
- the *external walls* extend to the underside of a *non-combustible* roof covering or *non-combustible* eaves lining in accordance with 3.7.2.4.

V2.3.1.3 Avoidance of the spread of fire [P2.3.1(b)] (adjoining allotment)

- Compliance with P2.3.1(b) to avoid the spread of fire between buildings on adjoining allotments is verified when it is calculated that—
 - a building will not cause heat flux in excess of those set out in column 2 of Table V2.3.1.3 at locations within the boundaries of an adjoining property set out in column 1 of Table V2.3.1.3 where another building may be constructed; and

Performance Provisions

- (ii) when located at the distances from the allotment boundary set out in column 1 of [Table V2.3.1.3](#), a building is capable of withstanding the heat flux set out in column 2 of [Table V2.3.1.3](#) without ignition.

Table V2.3.1.3

Column 1 (Location)	Column 2 (Heat flux [kW/m ²])
On boundary	80
1 m from boundary	40
3 m from boundary	20
6 m from boundary	10

Explanatory information:

[V2.3.1.3](#) is equivalent to [CV1](#) in Volume One of the NCC. Guidance on the use of [CV1](#) can be found in the Guide to Volume One of the NCC, and is applicable to the use of [V2.3.1.3](#).

V2.3.1.4 Avoidance of the spread of fire [P2.3.1(b)] (same allotment)

- (a) Compliance with [P2.3.1\(b\)](#) to avoid the spread of fire between buildings on the same allotment is verified when it is calculated that a building—
- (i) is capable of withstanding the heat flux set out in column 2 of [Table V2.3.1.4](#) without ignition; and
 - (ii) will not cause heat flux in excess of those set out in column 2 of [Table V2.3.1.4](#), when the distance between the buildings is as set out in column 1 of [Table V2.3.1.4](#).

Table V2.3.1.4

Column 1 (Location)	Column 2 (Heat flux [kW/m ²])
0 m	80
2 m	40
6 m	20
12 m	10

Explanatory information:

[V2.3.1.4](#) is equivalent to [CV2](#) in Volume One of the NCC. Guidance on the use of [CV2](#) can be found in the Guide to Volume One of the NCC, and is applicable to the use of [V2.3.1.4](#).

Part 2.4 Health and amenity

Explanatory information:

Objective

O2.4.1 Wet areas

The Objective is to safeguard the occupants from illness or injury and protect the building from damage caused by the accumulation of internal moisture arising from the use of *wet areas* in a building.

O2.4.2 Room heights

The Objective is to safeguard the occupants from injury or loss of amenity caused by inadequate height of a room or space.

O2.4.3 Facilities

The Objective is to—

- (a) safeguard occupants from illness caused by infection; and
- (b) safeguard occupants from loss of amenity arising from the absence of adequate personal hygiene facilities; and
- (c) enable occupants to carry out laundering; and
- (d) provide for facilities to enable food preparation; and
- (e) enable unconscious occupants of *sanitary compartments* to be removed from the compartment; and

O2.4.4 Light

The Objective is to safeguard occupants from injury, illness or loss of amenity due to—

- (a) isolation from natural light; and
- (b) lack of adequate artificial lighting.

O2.4.5 Ventilation

The Objective is to safeguard occupants from illness or loss of amenity due to lack of air freshness.

O2.4.6 Sound insulation

The Objective is to safeguard occupants from illness or loss of amenity as a result of undue sound being transmitted between adjoining dwellings.

Functional statements

F2.4.1 Wet areas

A building is to be constructed to avoid the likelihood of—

- (a) the creation of any unhealthy or dangerous conditions; or
- (b) damage to building elements, caused by dampness or water overflow from bathrooms, laundries and the like.

F2.4.2 Room heights

A building is to be constructed to provide height in a room or space suitable for the intended use.

F2.4.3 Facilities

A building is to be provided with suitable—

- (a) space and facilities for personal hygiene; and
- (b) space or facilities for laundering; and
- (c) space and facilities for the preparation and cooking of food; and
- (d) space or other means to permit an unconscious occupant to be removed from a *sanitary compartment*; and
- (e) means for the sanitary disposal of waste water.

Application:

F2.4.3 only applies to a Class 1 building.

F2.4.4 Light

- (a) A *habitable room* within a building is to be provided with openings to admit adequate natural light consistent with its function or use; and

Performance Provisions

- (b) A space within a building used by occupants is to be provided with artificial lighting consistent with its function or use which, when activated in the absence of suitable natural light, will enable safe movement.

F2.4.5 Ventilation

A space used by occupants within a building is to be provided with adequate ventilation consistent with its function or use.

F2.4.6 Sound insulation

A building element which separates dwellings is to be constructed to prevent undue sound transmission between those dwellings.

Performance Requirements

P2.4.1 Wet areas

To protect the structure of the building and to maintain the amenity of the occupants, water must be prevented from penetrating—

- (a) behind fittings and linings; or
 - (b) into concealed spaces,
- of sanitary facilities, bathrooms, laundries and the like.

P2.4.2 Room heights

A room or space must be of a height that does not unduly interfere with its intended function.

P2.4.3 Personal hygiene and other facilities

- (a) Suitable sanitary facilities for personal hygiene must be provided in a convenient location within or associated with a building, appropriate to its function or use.
- (b) * * * * *

This clause has been deliberately left blank.

- (c) Laundering facilities or space for laundering facilities and the means for sanitary disposal of waste water must be provided in a convenient location within or associated with a building, appropriate to its function or use.
- (d) A food preparation facility must be provided which includes—
 - (i) a means for food rinsing, utensil washing and the sanitary disposal of associated waste water; and
 - (ii) a means for cooking food; and
 - (iii) a space for food preparation.
- (e) A *sanitary compartment* must be constructed with sufficient space or other means to enable an unconscious occupant to be removed from the compartment.

Application:

P2.4.3 only applies to a Class 1 building.

Explanatory information:

For the purposes of P2.4.3(c), waste water includes water that is soiled as a result of clothes washing, mopping floors and other domestic cleaning processes.

P2.4.4 Lighting

- (a) A *habitable room* must be provided with *windows*, where appropriate to the function or use of that part of the building, so that natural light, when available, provides an *average daylight factor* of not less than 2%.
- (b) Artificial lighting must be installed to provide an *illuminance* of not less than 20 lux appropriate to the function or use of the building to enable safe movement by occupants.

Application:

Performance Provisions

P2.4.4(b) only applies—

- (a) to *sanitary compartments*, bathrooms, shower rooms, airlocks, laundries and the like; and
- (b) if natural light of a suitable standard is not available.

Explanatory information:

P2.4.4(a) nominates a minimum *average daylight factor* for rooms provided with natural light. Note that *Verification Method V2.4.4* provides a method by which the *average daylight factor* may be calculated.

To comply with P2.4.4(b), the level of artificial light must enable safe movement by occupants, appropriate to the use of the building. For example, in a movie room a lower level of lighting may be appropriate while a movie is being screened, however at the beginning and end of the movie when occupants are entering and exiting the movie room the minimum lighting level of 20 lux may be appropriate.

P2.4.5 Ventilation

- (a) A space within a building used by occupants must be provided with means of ventilation with *outdoor air* which will maintain adequate air quality.
- (b) A mechanical air-handling system installed in a building must control—
 - (i) the circulation of objectionable odours; and
 - (ii) the accumulation of harmful contamination by micro-organisms, pathogens and toxins.
- (c) Contaminated air must be disposed of in a manner which does not unduly create a nuisance or hazard to people in the building or *other property*.

P2.4.6 Sound insulation

- (a) Walls separating dwellings must provide insulation against the transmission of airborne sound sufficient to prevent illness or loss of amenity to the occupants.
- (b) Walls separating a bathroom, *sanitary compartment*, laundry or kitchen in a dwelling from a *habitable room* (other than a kitchen) in an adjoining dwelling, must provide insulation against impact generated sound sufficient to prevent illness or loss of amenity to the occupants.
- (c) The *required* sound insulation of walls must not be compromised by the incorporation or penetration of a pipe or other service element.

State and Territory Variations

In Northern Territory P2.4.6 is replaced with the following:

P2.4.6 Sound insulation

- (a) Walls separating dwellings must provide insulation against the transmission of airborne and impact generated sound sufficient to prevent illness or loss of amenity to the occupants.
- (b) The *required* sound insulation of walls must not be compromised by the incorporation or penetration of a pipe or other service element.

P2.4.7 Condensation and water vapour management

Risks associated with water vapour and *condensation* must be managed to minimise their impact on the health of occupants.

Application:

P2.4.7 only applies to a Class 1 building.

Verification Methods

V2.4.2 Room or space height

- (a) Compliance with P2.4.2 is verified where the height of a room or space provides an appropriate *activity support level* that does not unduly interfere with its intended function.

Performance Provisions

- (b) For a room or space in (a), the *activity support level* must consider the dimensions of—
- (i) doors, ramps, barriers, stairs and *windows*; and
 - (ii) fixed fittings and *domestic services*; and
 - (iii) fixed and moveable equipment or furniture; and
 - (iv) occupant circulation spaces.

Explanatory information:

The intent of P2.4.2 is the height of a room or space is sufficient for the intended use of the room or space. 'Intended use' recognises that the height required in a room or space is directly related to the room or space's intended function. V2.4.2 is a means to verify that the height of a room or space is suitable for the intended use, and therefore meets the requirement of P2.4.2.

In relation to the intended function of a room or space, the activities that are likely to be undertaken by occupants in the room of space, as well the features of the activities, are relevant considerations when determining a suitable height.

For example, if the intended use of a room is a gymnasium, then gymnastic activities are likely to be undertaken in the room. These activities often involve jumps and flips which require significant space in order to be undertaken safely.

In terms of the occupants, their features and needs are also relevant when determining a suitable height. For example, occupant features and needs would differ between rooms or spaces intended as a child's play area, and rooms or spaces intended for adult's indoor cricket.

The method requires the consideration of occupant characteristics and activity characteristics through the defined terms '*activity traits*', '*occupant traits*' and '*activity support level*'. Refer to Schedule 3 for more information on these terms.

When determining the *activity support level*, the method requires consideration of the relevant dimensions of items likely to be located in the room or space, as well as occupant circulation spaces.

Some of these considerations are—

- stairs and ramps, since the height of the room of the space will change relative to the occupant during incline and decline; and
- fixed fittings such as lights that may protrude from the ceiling and wash-basins; and
- domestic services such as air-conditioners, heaters, ceiling fans and heated water systems; and
- fixed equipment such manufacturing or processing equipment, permanent signage or displays and lifts; and
- moveable equipment such as whitegoods; and
- fixed furniture such as built-in wardrobes and permanent seating; and
- moveable furniture such as wardrobes, desks and beds; and
- occupant circulation spaces so that occupants can move comfortably and safety around the room or space.

For example, the location and dimensions of a wash-basin is a relevant consideration in determining the *activity support level* of a bathroom. This is because an occupant will typically need to access the wash-basin whilst standing, which will influence the necessary height of the space.

Another example is the consideration of moveable equipment such as a refrigerator in a kitchen. If the intended use of a space is a kitchen, then it would be unrealistic to determine a sufficient height for the room without considering the height of a typical refrigerator that would be located in the room.

V2.4.4 Verification of suitable natural light

Compliance with P2.4.4(a) is verified for the provision of natural light in all *habitable rooms* when the *average daylight factor* for each *window* is determined in accordance with the following formula:

Performance Provisions

$$\text{Average Daylight Factor} = \frac{W}{A} \frac{T\theta}{(1 - R^2)}$$

W = the net area of the light transmitting area of the *window* (m²); and

A = the total area of the internal wall, floor and ceiling surfaces (m²); and

T = the diffuse light transmittance of the *window*; and

θ = visible sky angle in degrees, measured in a vertical plane normal to and from the centre of the *window*; and

R = the area-weighted average reflectance of area A.

Explanatory information:

V2.4.4 is equivalent to FV4.3 in Volume One of the NCC. Guidance on the use of FV4.3 can be found in the Guide to Volume One of the NCC, and is applicable to the use of V2.4.4.

V2.4.5 Verification of suitable indoor air quality

For a Class 1 building, compliance with P2.4.5(a) and P2.4.5(b)(i) is verified when it is determined that the building under typical conditions in use is provided with sufficient ventilation with *outdoor air* such that contaminant levels do not exceed the limits specified in Table V2.4.5.

Table V2.4.5 Maximum contaminant limits for acceptable indoor air quality

Pollutant	Averaging Time	Maximum Air Quality Value
Carbon dioxide, CO ₂	8 hours	850 ppm ^{Note 1}
Carbon monoxide, CO	15 minutes	90 ppm
Carbon monoxide, CO	30 minutes	50 ppm
Carbon monoxide, CO	1 hour	25 ppm
Carbon monoxide, CO	8 hours	10 ppm
Formaldehyde, CH ₂ O	30 minutes	0.1 mg/m ³
Nitrogen dioxide, NO ₂	1 year	40 µg/m ³ (0.0197 ppm) ^{Note 2}
Nitrogen dioxide, NO ₂	1 hour	200 µg/m ³ (0.0987 ppm) ^{Note 2}
Ozone, O ₃	8 hour, daily maximum	100 µg/m ³ (0.0473 ppm)
Particulate matter, PM _{2.5}	1 year	10 µg/m ³
Particulate matter, PM _{2.5}	24 hour (99th percentile)	25 µg/m ³
Particulate matter, PM ₁₀	1 year	20 µg/m ³
Particulate matter, PM ₁₀	24 hour (99th percentile)	50 µg/m ³
Total volatile organic compounds	1 hour	500 µg/m ³

Notes to Table V2.4.5:

- Based on body odour metric (i.e. 450 ppm above ambient CO₂ level of 400 ppm and demand control ventilation provisions in AS 1668.2).
- Based on pressure of 101.325 kPa and temperature of 25 degrees (i.e. the conversion is mg/m³ = ppm (molecular weight/24.4)).

V2.4.6 Sound insulation

Compliance with P2.4.6(a) and (c) to insulate against transmission of airborne sound through walls separating dwellings is verified when it is measured in-situ that the wall has a weighted standardised level difference with spectrum adaptation term ($D_{nT,w} + C_{tr}$) not less than 45 when determined under AS/NZS ISO 717.1.

State and Territory Variations

V2.4.6 does not apply in Northern Territory.

V2.4.7 Verification of condensation management

Compliance with P2.4.7 is verified when modelling that assesses the effects of—

- (a) indoor and outdoor temperature and humidity conditions; and
- (b) heating and cooling set points; and
- (c) rain absorption; and
- (d) wind pressure; and
- (e) solar radiation; and
- (f) material hygrothermal properties,
determines that moisture will not accumulate—
- (g) interior to the primary *water control layer* within a building envelope; or
- (h) on the interior surface of the *water control layer*.

Part 2.5 Safe movement and access

Explanatory Information:

Objective

O2.5

The Objective is to provide people with safe access to and within a building.

Functional statements

F2.5.1 Safety from falling

A building is to provide safe access for people to the services and facilities within.

Performance Requirements

P2.5.1 Movement to and within a building

So that people can move safely to and within a building—

- (a) walking surfaces must have safe gradients; and
- (b) any stairway or ramp must—
 - (i) have suitable handrails where necessary to assist and provide stability to people using the stairway or ramp; and
 - (ii) have suitable landings to avoid undue fatigue of users; and
 - (iii) be suitable for safe passage in relation to the nature, volume and frequency of likely usage; and
 - (iv) have slip-resistant walking surfaces on ramps, and on stairway treads or near the edge of the nosing.

P2.5.2 Fall prevention barriers

Where people could fall—

- (a) 1 m or more—
 - (i) from a floor or roof or through an opening (other than through an openable window) in the *external wall*; or
 - (ii) due to a sudden change of level within or associated with a building; or
- (b) 2 m or more from a floor through an openable window in a bedroom; or
- (c) 4 m or more from a floor through an openable window not covered by (b),
a barrier must be provided which must be—
 - (d) continuous and extend for the full extent of the hazard; and
 - (e) of a height to protect people from accidentally falling from the floor or roof or through the opening or openable window; and
 - (f) constructed to prevent people from falling through the barrier; and
 - (g) capable of restricting the passage of children; and
 - (h) of strength and rigidity to withstand—
 - (i) the foreseeable impact of people; and
 - (ii) where appropriate, the static pressure of people pressing against it.

Verification Methods

V2.5.1 Wire barriers

Compliance with P2.5.2(f) and (g) for wire barriers is verified when the wire barrier passes the test described below:

- (a) **Application**

Performance Provisions

The test must be carried out on either—

- (i) a prototype of a wire barrier that is identical to that proposed to be installed on site; or
- (ii) a wire barrier installed on site.

(b) **Test equipment**

The test equipment must consist of the following:

- (i) A horizontally suspended 125 mm diameter, 405 mm long cylinder of 1 mm thick steel having a highly polished 105 mm long cone at one end with a 20 mm diameter flat leading edge to which an eye bolt is fixed.
- (ii) A sufficiently flexible horizontal cable with mechanisms capable of applying and measuring a tension of 150 N (or a 15.3 kg weight suspended over a low friction pulley) is to be attached to the eye bolt (see [Figure V2.5.1](#)).
- (iii) A mechanism capable of measuring the tension force applied to each wire.

Figure V2.5.1 Apparatus for testing wire barriers

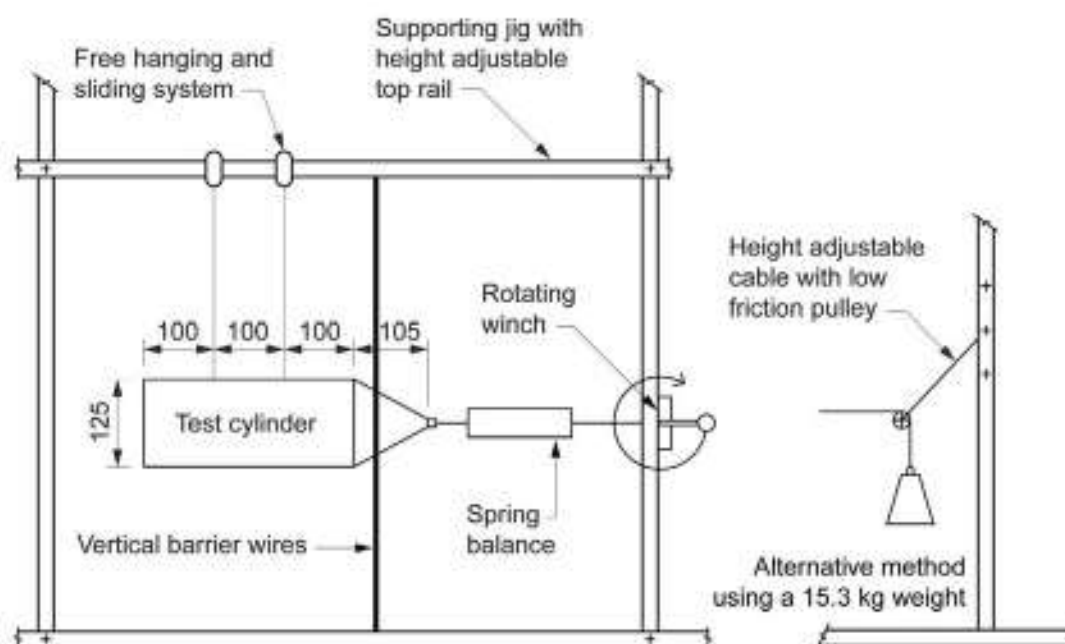

(c) **Test procedure**

The test procedure must be as follows:

- (i) Tension the wires, within their safe load, to the same tension in all wires and measure the tensions with a strain indicator.
- (ii) For—
 - (A) horizontal or near horizontal wires, position the cone against a pair of wires at the mid-span between supports, then apply the 150 N tension force to the cone; and
 - (B) vertical wires, position the cone against a pair of wires at the mid-span between supporting rails, then apply the 150 N tension force to the cone; and
 - (C) near-vertical wires, position the cone against a pair of wires at the widest opening between the wires, then apply the 150 N tension force to the cone.
- (iii) Attempt to pull the cone through the gap between the wires under the 150 N load, and—
 - (A) increase the tension in the wires and repeat (ii) until such time as the cone will not pull through; or
 - (B) if it does not pull through, reduce the tension in the wires and repeat step (ii).
- (iv) When the cone is just prevented from pulling through the gap, the wires are at the correct tension in which case the cone is withdrawn and the tension recorded.

Performance Provisions

- (v) Reduce the tension in the wires and repeat steps (ii) to (iv) twice more, recording the tension in each case after the cone has been removed and then calculate the average of the three tensions as the *required* tension for each wire.
 - (vi) For prototype tests of horizontal or near horizontal wires, record the deflection of each wire at the average tension calculated in accordance with (v) when a 2 kg mass is hung at mid-span between supports.
- (d) **Test report**
- The test report must include the following information:
- (i) The name and address of the person supervising the test.
 - (ii) The test report number.
 - (iii) The date of the test.
 - (iv) The wire manufacturer's name and address, and specifications of the wires used in the test including the safe load limit of the wires.
 - (v) The construction details of the test specimen, including a description and drawings and details of the components including supports, post or railing spacings and wire spacings.
 - (vi) For a prototype test, the *required* tension calculated in accordance with (c)(v).
 - (vii) For prototype tests of horizontal or near horizontal wires, the deflection measured in accordance with (c)(vi).

Explanatory information:

V2.5.1 is a means to verify that a proposed wire barrier satisfies the requirements of P2.5.2(f) and (g).

The meaning of the phrase "prototype that is identical to that proposed to be installed" is similar to the testing of prototypes for fire resistance. That is the prototype and the installation must be identical with respect to the type of wire, the wire diameter, the number of lays, the wire tension, the post spacing and size, etc.

The test procedure is slightly different for barriers with horizontal or near horizontal wires and vertical wires or near vertical wires (see the test procedures set out in V2.5.1(c)(ii)).

V2.5.1(c)(vi) allows measuring deflection of wires to verify that the *required* tension has been achieved.

It should be noted that V2.5.1 is only one form of compliance solution which can be used to demonstrate compliance with P2.5.2(f) and (g). The following means of verification are available:

- (a) V2.5.1.
- (b) The *Deemed-to-Satisfy Provisions* in 3.9.2.5.
- (c) A *Performance Solution* that uses one of the other NCC *Assessment Methods* which verifies that P2.5.2(f) and (g) will be achieved.

See also explanatory information to 3.9.2.5.

Part 2.6 Energy efficiency

Note:

From 1 May 2019 to 30 April 2020 Part 2.6 of NCC 2016 Volume Two may apply instead of [Part 2.6](#) of NCC 2019. From 1 May 2020 [Part 2.6](#) of NCC 2019 applies.

State and Territory Variations

(a) In New South Wales, [Part 2.6](#) does not apply.

Note: The New South Wales Additions contain energy efficiency measures that apply in New South Wales to support and complement BASIX.

(b) In the Northern Territory, [Part 2.6](#) is replaced with BCA 2009 Part 2.6.

Explanatory information:

Objective

O2.6

The Objective is to reduce greenhouse gas emissions.

Functional statements

F2.6

To reduce greenhouse gas emissions, to the degree necessary—

- (a) a building, including its *domestic services*, is to be capable of efficiently using energy; and
- (b) a building's *domestic services* for heating are to obtain their energy from—
 - (i) a low greenhouse gas intensity source; or
 - (ii) an on-site *renewable energy* source; or
 - (iii) another process as reclaimed energy.

Explanatory information:

1. The greenhouse gas intensity of energy sources vary. For example, natural gas has a low greenhouse gas intensity compared with electricity generated from coal.
2. For the purposes of F2.6, the *renewable energy* source must be on-site (so not Greenpower) and includes, but is not limited to, solar, wind, hydroelectric, wave action and geothermal.

Performance Requirements

P2.6.1 Building

A building must have, to the degree necessary, a level of thermal performance to facilitate the efficient use of energy for artificial heating and cooling appropriate to—

- (a) the function and use of the building; and
- (b) the internal environment; and
- (c) the geographic location of the building; and
- (d) the effects of nearby permanent features such as topography, structures and buildings; and
- (e) solar radiation being—
 - (i) utilised for heating; and
 - (ii) controlled to minimise energy for cooling; and
- (f) the sealing of the building *envelope* against air leakage; and
- (g) the utilisation of air movement to assist cooling.

Explanatory information:

Performance Provisions

In P2.6.1(d) the term “permanent” is used to describe features that will have a long term impact on the building and includes natural features of the landscape, such as mountains and escarpments, while permanent man made features would be buildings likely to be in place for a long period of time.

State and Territory Variations

P2.6.1 is replaced in Victoria as follows:

P2.6.1 Building

A building must have, to the degree necessary, a level of thermal performance to facilitate the efficient use of energy for artificial heating and cooling and a level of water use performance to facilitate the efficient use of water, appropriate to—

- (a) the function and use of the building; and
- (b) the internal environment; and
- (c) the geographic location of the building; and
- (d) the effects of nearby permanent features such as topography, structures and buildings; and
- (e) solar radiation being—
 - (i) utilised for heating; and
 - (ii) controlled to minimise energy for cooling; and
- (f) the sealing of the building *envelope* against air leakage; and
- (g) the utilisation of air movement to assist cooling; and
- (h) water resources available; and
- (i) pertinent water management measures of the responsible water authority.

P2.6.2 Services

Domestic services, including any associated distribution system and components must, to the degree necessary—

- (a) have features that facilitate the efficient use of energy appropriate to—
 - (i) the *domestic service* and its usage; and
 - (ii) the geographic location of the building; and
 - (iii) the location of the *domestic service*; and
 - (iv) the energy source; and
- (b) obtain heating energy from—
 - (i) a source that has a greenhouse gas intensity that does not exceed 100 g CO₂-e/MJ of thermal energy load; or
 - (ii) an on-site *renewable energy* source; or
 - (iii) another process such as reclaimed energy.

Explanatory information:

1. For (a)(iv) the energy source can be a consideration if, for example, *renewable energy* such as electricity from a photovoltaic panel or a wind turbine was used to meet or supplement the lighting or cooling electricity load. For (b)(ii) similar sources could meet or supplement the heating load.
2. The intent of P2.6.2(b) is to constrain the use of a high greenhouse gas intensity source of energy. It does not prevent the use of electricity because the greenhouse gas intensity is related to the thermal load rather than the energy consumption which is covered by P2.6.2(a). P2.6.2 also contains the qualification that it is to be applied “to the degree necessary”, allowing electricity to be used, even by low efficiency plant when there are no reasonable alternatives.
3. For the purposes of P2.6.2 the *renewable energy* source must be on-site (so not Greenpower) and includes, but is not limited to, solar, wind, hydroelectric, wave action and geothermal.

State and Territory Variations

In Victoria, P2.6.2 does not apply to a hot water supply system.

Performance Provisions

Note: In Victoria, the design and installation of a hot water supply system is regulated under the Plumbing Regulations 2018.

Verification Methods

V2.6.1 Application of this Part

The *Verification Methods* in this Part only apply to—

- (a) a Class 1 building; and
- (b) an enclosed Class 10a building attached to a Class 1 building.

Explanatory information:

The *Verification Methods* in this Part are intended to apply to whole Class 1 buildings and to whole Class 1 buildings that incorporate attached and enclosed Class 10a parts, such as attached garages. The *Verification Methods* are not intended to apply to detached garages or to open carports.

State and Territory Variations

V2.6.1 is replaced in Victoria as follows:

V2.6.1 Application of this Part

The *Verification Methods* in this Part only apply to—

- (a) a new Class 1 building that has either a rainwater tank connected to all sanitary flushing systems, or a solar water heater system, installed in accordance with the Plumbing Regulations 2018; and
- (b) a Class 1 building other than a new Class 1 building; and
- (c) an enclosed Class 10a building attached to a Class 1 building.

V2.6.2 * * * * *

This clause has deliberately been left blank.

V2.6.2.1 * * * * *

This clause has deliberately been left blank.

V2.6.2.2 Verification using a reference building

- (a) Compliance with P2.6.1 is verified when a proposed building—
 - (i) compared to a *reference building*, using a calculation method other than *house energy rating software*, has—
 - (A) in *climate zones* 1 and 2, a *cooling load* equal to or less than that of the *reference building*; or
 - (B) in *climate zones* 7 and 8, a *heating load* equal to or less than that of the *reference building*; or
 - (C) in *climate zones* 3, 4, 5 and 6, a *heating load* and a *cooling load* equal to or less than that of the *reference building*; and
 - (ii) complies with—
 - (A) for building *fabric* thermal insulation, 3.12.1.1; and
 - (B) for thermal break, 3.12.1.2(c) and 3.12.1.4(d); and
 - (C) for compensating for a loss of ceiling insulation, 3.12.1.2(e); and
 - (D) for floor edge insulation, 3.12.1.5(c) and 3.12.1.5(d); and
 - (E) for building sealing, Part 3.12.3 or V2.6.2.3.
- (b) The *heating loads* and *cooling loads* in (a) must be calculated for the *reference building* using—
 - (i) internal heat gains from appliances and equipment of 5 W/m² averaged for 24 hours per day, 7 days per week; and

Performance Provisions

- (ii) an infiltration value of 0.6 air changes per hour; and
- (iii) the modelling criteria in [Table V2.6.2.2](#).

Table V2.6.2.2 Reference building requirements

Item	Description	Criteria to be modelled
1	Roof	Pitched roof (23 degrees) with solar absorptance of 0.6
2	Ceiling	2.4 m high horizontal, 10 mm plasterboard ceiling
3	Roof and ceiling insulation	In accordance with Tables 3.12.1.1a to 3.12.1.1g
4	Roof lights	No <i>roof light</i> , unless <i>required</i> by Part 3.8.4
5	External walls	Masonry veneer with 110 mm thick masonry with a solar absorptance of 0.6
6	Wall insulation	The minimum <i>Total R-Value</i> specified in 3.12.1.4(b)
7	Internal walls	70 mm timber frame with 10 mm internal plaster lining
8	Ground floor	Concrete slab-on-ground, insulated in accordance with 3.12.1.5(c)
9	Glazing	In accordance with Part 3.12.2
10	Air movement	In accordance with Part 3.12.4
11	Artificial lighting	In accordance with the maximum <i>illumination power density</i> allowed by 3.12.5.5 without any increase for a control device <i>illumination power density</i> adjustment factor

- (c) The *heating load* and *cooling load* for the proposed building and the *reference building* must be determined using the same—
- (i) calculation method; and
 - (ii) location specific data, including that of climate and topography appropriate to the location where the proposed building is to be constructed if the data is available, or the nearest location with similar climatic conditions in the same *climate zone* for which the data is available; and
 - (iii) impact of adjoining structures and features; and
 - (iv) soil conditions; and
 - (v) orientation; and
 - (vi) floor plan, including the location and size of *glazing*; and
 - (vii) number of storeys; and
 - (viii) roof cladding and *roof lights*; and
 - (ix) *separating walls*; and
 - (x) external non-glazed doors; and
 - (xi) intermediate floors; and
 - (xii) floor coverings; and
 - (xiii) internal heat gains from equipment and appliances; and
 - (xiv) air infiltration and ventilation; and
 - (xv) function and use of the building and spaces, including zoning, hours of occupation, hours of heating and cooling availability; and

Performance Provisions

- (xvi) space temperature settings within the ranges of 20°C to 21°C for heating and 25°C to 28°C for cooling; and
 - (xvii) the profiles for occupancy and air-conditioning.
- (d) The calculation method used must comply with ANSI/ASHRAE Standard 140 and be capable of assessing the *heating load* and *cooling load* by modelling—
- (i) the building *fabric*; and
 - (ii) *glazing* and shading; and
 - (iii) air infiltration and ventilation; and
 - (iv) the function and use of the building including zoning, hours of occupation, hours of heating and cooling availability and internal heat gains; and
 - (v) relevant built-environment and topographical features; and
 - (vi) the sensible heat component of the *cooling load* and *heating load*.
- (e) Climatic data employed in the calculation method must be based on hourly recorded values and be representative of a typical year for the proposed location.

Explanatory information:

1. The items listed in (c) must be the same for both the proposed building and *reference building*. This means that those factors applicable to the proposed building must be applied to the *reference building*. For example, if the proposed building is subject to overshadowing by an existing adjoining building, in accordance with (c)(iii) the same overshadowing must be applied to the *reference building*.
2. In (d)(iv), the number of hours per day for which heating and cooling is available would be expected to lie between 8 and 17, with values outside this range unlikely in other than exceptional circumstances.
3. To comply with (c)(xv) all internal zones need to be modelled for each internal area. For example, zones for *conditioned spaces*, unconditioned spaces, day time, night time and the like appropriate to their intended usage. It is expected that each room including significant hallways will be modelled as a separate thermal zone.
4. Suitable climatic data including dry-bulb temperature, direct and diffuse solar radiation, wind speed, wind direction and cloud cover can be obtained from the Australian national climate database.

V2.6.2.3 Verification of building envelope sealing

Compliance with P2.6.1(f) is verified when a building *envelope* is sealed at an air permeability of not more than 10 m³/hr.m² at 50 Pa reference pressure when tested in accordance with AS/NZS ISO 9972 Method 1.

Explanatory information

The intent is that 10 m³/hr.m² at 50 Pa is broadly equivalent to 10 air changes per hour at 50 Pa when applied to homes. It should be noted that V2.6.2.3 is only one way of achieving compliance with P2.6.1(f). Other ways of complying include the following:

- (a) The relevant provisions of Part 3.12.3.
- (b) A *Performance Solution* that uses one of the other NCC *Assessment Methods* which verifies that compliance with P2.6.1(f) will be achieved.

V2.6.3 * * * * *

This clause has deliberately been left blank.

Explanatory information:

The content of V2.6.3, which existed in BCA 2013, has been moved to Part B2 of NCC Volume Three — Plumbing Code of Australia.

Part 2.7 Ancillary provisions and additional construction requirements

Explanatory information:

Objective

O2.7

The Objective is to—

- (a) safeguard young children from drowning or injury in a *swimming pool*; and
- (b) safeguard people from drowning or injury due to suction by a *swimming pool* water recirculation system; and
- (c) safeguard the occupants from illness or injury caused by fire from heating appliances installed within the building; and
- (d) safeguard the occupants from illness or injury in *alpine areas* from an emergency while evacuating the building; and
- (e) protect a building from the effects of a bushfire; and
- (f) reduce the likelihood of fatalities arising from occupants of a Class 1a dwelling not evacuating a property prior to exposure from a bushfire event.

Application:

O2.7(a) and (b) only apply to a *swimming pool* with a depth of water more than 300 mm.

O2.7(f) only applies to a Class 10c building.

Functional statements

F2.7.1 Swimming pool access

A *swimming pool* is to be provided with—

- (a) means to restrict access to it by young children; and
- (b) means to reduce the possibility of a person being entrapped or injured due to suction by a water recirculation system.

Application:

F2.7.1 only applies to a *swimming pool* with a depth of water more than 300 mm.

F2.7.2 Heating appliances

Heating appliances using controlled combustion located in a building are to be installed in a way which reduces the likelihood of—

- (a) fire spreading beyond the appliance; and
- (b) smoke from the appliance entering the building.

F2.7.3 Alpine areas

A building in an *alpine area* is to be provided with additional measures in view of the increased difficulties in fighting fire and maintaining access and means of egress in snow conditions.

F2.7.4 Bushfire areas

A Class 1 building or a Class 10a building or deck associated with a Class 1 building constructed in a *designated bushfire prone area* is to provide resistance to bushfires in order to reduce the danger to life and reduce the risk of the loss of the building.

F2.7.5 Private bushfire shelters

A structure designed for emergency occupation during a bushfire event must provide shelter to occupants from direct and indirect actions of a bushfire.

Application:

F2.7.5 only applies to a Class 10c building.

Performance Requirements

P2.7.1 Swimming pool access

A barrier must be provided to a *swimming pool* and must—

Performance Provisions

- (a) be continuous for the full extent of the hazard; and
- (b) be of a strength and rigidity to withstand the foreseeable impact of people; and
- (c) restrict the access of young children to the pool and the immediate pool surrounds; and
- (d) have any gates and doors fitted with latching devices not readily operated by young children, and constructed to automatically close and latch.

Application:

P2.7.1 only applies to a *swimming pool* with a depth of water more than 300 mm.

State and Territory Variations

(a) **P2.7.1 applies in New South Wales** to a *swimming pool* with a depth of water of more than 300 mm, in conjunction with the Swimming Pools Act 1992 and the Swimming Pools Regulation 2018.

(b) **P2.7.1 does not apply in the Northern Territory.**

Note: Restriction of access to *swimming pools* in the Northern Territory is regulated under the Swimming Pool Safety Act.

(c) **P2.7.1 does not apply in Queensland.**

Note: Restriction of access to *swimming pools* in Queensland is regulated under the Building Act 1975.

P2.7.2 Swimming pool recirculation systems

A *swimming pool* water recirculation system must incorporate safety measures to avoid entrapment of, or injury to, a person.

Application:

P2.7.2 only applies to a *swimming pool* with a depth of water more than 300 mm.

P2.7.3 Heating appliances

A heating appliance and its associated components within a building, including an open fire-place, chimney, or the like, must be installed—

- (a) to withstand the temperatures likely to be generated by the appliance; and
- (b) so that it does not raise the temperature of any building element to a level that would adversely affect the element's physical or mechanical properties or function; and
- (c) so that hot products of combustion will not—
 - (i) escape through the walls of the associated components; and
 - (ii) discharge in a position that will cause fire to spread to nearby *combustible* materials or allow smoke to penetrate through nearby *windows*, ventilation inlets, or the like in the building containing the heating appliance.

State and Territory Variations

P2.7.3(c) has been replaced in Tasmania as follows:

P2.7.3(c)

- (c) so that hot products of combustion will not—
 - (i) escape through the walls of the associated components; and
 - (ii) discharge in a position that will cause fire to spread to nearby *combustible* materials or allow smoke to penetrate through nearby *windows*, ventilation inlets, or the like in the building containing the heating appliance; and
 - (iii) in the case of solid-fuel burning appliances, be discharged above appropriate emission limits.

P2.7.4 Buildings in alpine areas

- (a) An external doorway from a building in an *alpine area* must be installed so that opening the door is not obstructed by snow or ice.

Performance Provisions

- (b) A building in an *alpine area* containing external trafficable structures forming part of the means of egress must be constructed so that they remain, as far as practicable, useable under snow conditions.
- (c) A building in an *alpine area* must be constructed so that snow or ice is not shed from the building onto the allotment, any adjoining allotment, road or public space in a location or manner that will—
 - (i) obstruct a means of egress from any building to a road or open space; or
 - (ii) otherwise endanger people.

P2.7.5 Buildings in bushfire prone areas

A Class 1 building or a Class 10a building or deck associated with a Class 1 building that is constructed in a *designated bushfire prone area* must, to the degree necessary, be designed and constructed to reduce the risk of ignition from a bushfire, appropriate to the—

- (a) potential for ignition caused by burning embers, radiant heat or flame generated by a bushfire; and
- (b) intensity of the bushfire attack on the building.

State and Territory Variations

P2.7.5 has been replaced in Tasmania as follows:

A Class 1 building or a Class 10a building or deck associated with a Class 1 building that is constructed in a *designated bushfire prone area* must, to the degree necessary, be—

- (a) designed and constructed to reduce the risk of ignition from a bushfire, appropriate to the—
 - (i) potential for ignition caused by burning embers, radiant heat or flame generated by a bushfire; and
 - (ii) intensity of the bushfire attack on the building; and
- (b) provided with vehicular access to the *site* to assist fire fighting and emergency personnel defend the building or evacuate occupants; and
- (c) provided with access at all times to a sufficient supply of water for fire fighting purposes on the *site*.

P2.7.6 Private bushfire shelters

A *private bushfire shelter* must be designed and constructed to provide a tenable environment for occupants during the passage of untenable conditions arising from a bushfire event, appropriate to the—

- (a) location of the *private bushfire shelter* relative to fire hazards including—
 - (i) predominant vegetation; and
 - (ii) adjacent buildings and structures; and
 - (iii) allotment boundaries; and
 - (iv) other combustible materials; and
- (b) occupancy of the *private bushfire shelter*; and
- (c) bushfire intensity having regard for the bushfire attack level; and
- (d) fire intensity from adjacent buildings and structures, allotment boundaries and other combustible materials; and
- (e) ready access to the *private bushfire shelter* from the associated dwelling and occupant egress after the fire; and
- (f) tenability within the *private bushfire shelter* for the estimated maximum period of occupancy; and
- (g) generation of smoke, heat and toxic gases from materials used to construct the *private bushfire shelter*; and
- (h) structural and fire loads and actions to which it may reasonably be subjected, appropriate to—
 - (i) the topography between the *private bushfire shelter* and the predominant vegetation or other fire hazards; and
 - (ii) the distance between the *private bushfire shelter* and the predominant vegetation or other fire hazards; and
 - (iii) the size of the potential fire source and fire intensity; and
 - (iv) wind loading; and
 - (v) potential impact from debris such as falling tree limbs; and

Performance Provisions

- (i) degree of external signage identifying the location of the *private bushfire shelter*; and
- (j) degree of internal signage identifying the design capacity and maximum period of occupancy; and
- (k) degree of occupant awareness of outside environmental conditions; and
- (l) degree of essential maintenance.

Application:

P2.7.6 only applies to a Class 10c building.

Note:

The *Housing Provisions* do not contain any *Deemed-to-Satisfy Provisions* for this *Performance Requirement*, however the ABCB Performance Standard for Private Bushfire Shelters contains guidance for this *Performance Requirement*.

Verification Methods

V2.7.1 Combustion appliances

Compliance with P2.7.3(a) and (b) is verified when—

- (a) components used within an appliance and its installation are constructed from—
 - (i) heat-resistant materials for maximum operating temperatures more than 600°C, where the material complies with (c); or
 - (ii) heat-tolerant materials for maximum operating temperatures more than 150°C and less than 600°C, where the material complies with (c); and
- (b) the building elements surrounding the appliance maintain their designed function and material properties inclusive of a full range of thermal movements when exposed to the heat effects of the appliance; and
- (c) a sample of the material is tested to the maximum operating temperature, specified in (a)(i) or (a)(ii) for a minimum of 96 hours and the tested sample complies with the following:
 - (i) When allowed to cool, the tested sample must be free from—
 - (A) visible cracks and fractures; and
 - (B) visible indication of de-lamination; and
 - (C) linear distortion in excess of the equivalent of 10 mm per metre; and
 - (D) deterioration of the appearance of any surface finish, when compared to an unheated sample.

Explanatory information:

Under V2.7.1, the user needs to demonstrate that the proposed appliance will not deteriorate under standard operating conditions. Examples of deterioration may include deformation or failure of components that would render the appliance unsafe to use.

For the purposes of demonstrating compliance with sub-clause (a), the typical operating temperature of a combustion device can be established by testing.

For the purposes of demonstrating compliance with sub-clause (b), materials used for building elements (walls, floors and ceiling) in the areas surrounding an appliance can be appropriately selected and/or designed to align with the quantified values as determined by sub-clause (a). This could either be achieved by using *Expert Judgement* or by adhering to manufacturer's specifications. Certification in accordance with CodeMark Australia would also be a possibility in demonstrating compliance using the *Verification Method*.

Full range of thermal movements relates to both the appliance and materials when exposed to both the heated and ambient conditions,

Benefits to industry derived from the application of this *Verification Method* includes the potential use of non-standard national or internationally manufactured appliances. For example, test reports from appliances complying with various ISO Standards and various British Standards could be used to demonstrate compliance with the *Verification Method*. The *Verification Method* also allows for in situ testing of unique combustion appliances, which would not easily be tested in accordance with the Australian Standard. Such testing would need to be verified by a suitably qualified practitioner and be supported by appropriate documentation.

Performance Provisions

V2.7.2 Buildings in bushfire prone areas

- (a) Compliance with [P2.7.5](#) is verified if the ignition probability for a building exposed to a design bushfire does not exceed 10%.
- (b) Bushfire design actions must be determined in consideration of the annual probability of a design bushfire derived from—
- (i) assigning the building or structure with an importance level in accordance with [\(c\)](#); and
 - (ii) determining the corresponding annual probability of exceedance in accordance with [Table V2.7.2](#).
- (c) A building or structure's importance level must be identified as one of the following:
- (i) Importance level 1 — where the building or structure presents a low degree of hazard to life and *other property* in the case of failure.
 - (ii) Importance level 2 — where the building or structure is not of importance level 1 or 4 and is a Class 1a or 1b building accommodating 12 people or less.
 - (iii) Importance level 4 — where the building is a Class 10c building and is subject to a necessary 'defend in place' strategy.

Table V2.7.2 Annual Probability of Exceedance (APE) for design bushfire actions

Importance level	Complex analysis APE for bushfire exposure	Simple analysis APE for weather conditions (design bushfire)
1	No requirement	No requirement
2	1:500	1:50
3	N/A for Class 1 and 10 buildings	N/A for Class 1 and 10 buildings
4	1:2000	1:200

Note to Table V2.7.2: Complex analysis must consider the probability of ignition, fire spread to the urban interface and penetration of the urban interface coincident with fire weather conditions.

Explanatory information:

Volume Two does not apply to buildings that are importance level 3, therefore this importance level is not included under [\(c\)](#).

- (d) The ignition probability for a building must be assessed by application of the following:
- (i) An event tree analysis of relevant bushfire scenarios.
 - (ii) Design bushfire conditions that include combinations of the following actions appropriate to the distance between the building and the bushfire hazard:
 - (A) Direct attack from airborne burning embers.
 - (B) Burning debris and accumulated embers adjacent to a building element.
 - (C) Radiant heat from a bushfire front.
 - (D) Direct flame attack from a bushfire front.
- (e) Applied fire actions must allow for reasonable variations in—
- (i) fire weather; and
 - (ii) vegetation, including fuel load, burning behaviour of vegetation (including the potential for crown fires); and
 - (iii) the distance of the building from vegetation; and
 - (iv) topography, including slopes and features that may shield; and
 - (v) ignition of adjacent buildings, building elements, plants, mulch and other materials; and
 - (vi) effective size of fire front; and
 - (vii) duration of exposure; and
 - (viii) flame height; and
 - (ix) flame tilt; and

Performance Provisions

- (x) flame adhesion to sloping land; and
- (xi) the height of the building and its elements.
- (f) The assessment process must include consideration of—
 - (i) the probability of non-complying construction of critical aspects of an approved design; and
 - (ii) the probability of critical aspects of an approved design being fully functional during the life of the building; and
 - (iii) inclusion of safety factors; and
 - (iv) sensitivity analysis of critical aspects of a proposed design.

Acceptable Construction

How to use Section 3

Part 3.0 Structural provisions

Section 3 Acceptable Construction

How to use Section 3

Introduction

The scope of these provisions

Suitability of Performance Solutions

The use of maps

Consultation with appropriate authorities

Layout of Parts 3.0 to 3.12

Interpretation

How to use the requirements of each Part

Part 3.0 Structural provisions

Acceptable Construction Practice

3.0.1 Application

3.0.2 Resistance to actions

3.0.3 Determination of individual actions

3.0.4 Determination of structural resistance of materials and forms of construction

3.0.5 Structural software

How to use Section 3

Explanatory information:

This is a non-mandatory guide on how to use Section 3 of the [Housing Provisions](#).

Introduction

Section 3, [Parts 3.0 to 3.12](#) are [Deemed-to-Satisfy Provisions](#) that are considered to be acceptable forms of construction that meet the legislative requirements for complying with the [Housing Provisions](#) (i.e. they comply with the [Performance Requirements](#) listed in Section 2 of the [Housing Provisions](#)).

There is no obligation to adopt any particular option contained in Section 3 of the [Housing Provisions](#), if it is preferred to meet the [Performance Requirement](#) in some other way.

However, if one of the options described in Section 3 is not complied with, then the [appropriate authority](#) must be satisfied that the [Performance Requirements](#) have been met.

The scope of these provisions

In Section 3 of Volume Two the [Deemed-to-Satisfy Provisions](#) are divided into two compliance pathways; “acceptable construction practices” and “acceptable construction manuals”.

- “Acceptable construction practices” are some of the most common forms of national construction practice and are written into Section 3.
- “Acceptable construction manuals” are the deemed-to-satisfy referenced documents.

In general, either an “acceptable construction practice” or an “acceptable construction manual” may be used as options when proposing a [Deemed-to-Satisfy Solution](#).

However, it should be noted that not all Parts within Section 3 contain both an “acceptable construction practice” and an “acceptable construction manual” compliance option. Some Parts within Section 3 may contain only an “acceptable construction practice” option (e.g. [Part 3.7.2 Fire separation of external walls](#)) or an “acceptable construction manual” (e.g. [Part 3.10.1 Swimming Pools](#)). Where an “acceptable construction practice” and an “acceptable construction manual” contained in the same Part of Section 3 are deemed-to-satisfy the same component of a [Performance Requirement](#), in order to comply with the [Deemed-to-Satisfy Provisions](#) it is only necessary to satisfy the “acceptable construction practice” or one of the “acceptable construction manuals” listed.

Some of these options described as “acceptable construction practice” may have very specific limitations and accordingly will not be suitable for all applications. In the case of the “acceptable construction practice”, these limitations generally relate to climatic ([design wind speed](#)), geographical and topographical conditions and building geometry or in specific cases, may have a limiting scope that does not fully cover the subject matter of the Part. In the case of the “acceptable construction manual”, the scope may be limited to specific components of the subject matter.

If the “acceptable construction practice” option is not suitable for the proposed construction or [site](#) conditions, an alternative approach may be found in one of the “acceptable construction manuals” listed at the start of each Part.

[Part 3.0](#) of Section 3 contains a number of structural design manuals, which can be used to design building elements using engineering principles.

There is no obligation for the provisions of [Part 3.0](#) to be used apart from situations where a particular building, building element or component is [required](#) to comply with the [Housing Provisions](#) and is not contained in the scope of the “acceptable construction practice” or the “acceptable construction manual”.

[Part 3.10](#) contains additional construction requirements that are ancillary to the construction of a building or structure, such as the construction of [swimming pools](#), heating appliances, fireplaces, methods of attaching decks and balconies to [external walls](#) and the like. [Part 3.10](#) also addresses additional construction requirements for buildings constructed in areas subject to geographical, topographical or climatic conditions that are beyond the scope of the preceding Parts of the [Housing Provisions](#). The [Part 3.10](#) provisions are to be read in conjunction with the other relevant requirements of the [Housing Provisions](#).

Situations where it is necessary for a mixed application of the “acceptable construction practice” and the “acceptable construction manual” may be identified by reference to differing components of the [Performance Requirement](#) (see [A2.3](#)). (For further explanation on the scope of the Section 3 [Deemed-to-Satisfy Provisions](#) see [A2.3](#)).

Suitability of Performance Solutions

The options described in Section 3 are typical examples of national construction methods. They are certainly not the only means available of complying with the *Housing Provisions*. The performance format of the *Housing Provisions* provides flexibility and allows the use of alternative construction methods to those described in the *Deemed-to-Satisfy Provisions*. *Performance Solutions* may be used provided they comply with the *Performance Requirements* listed in Section 2 (for further explanation see [Part A2](#)).

The use of maps

Maps have been used throughout Section 3 to indicate areas where particular requirements apply. These maps are indicative and some variation in conditions will apply, especially on the border of marked areas.

It is recommended that the *appropriate authority* be consulted and in most cases they may be able to identify what conditions apply in such areas at the early stage of building design.

Consultation with appropriate authorities

When building in certain locations there may be local conditions or other site constraints that may limit the type of construction that can be used. This is particularly important with buildings that are constructed in areas subject to increased structural loading conditions that may occur due to geographical, topographical or climatic conditions and soil types.

Appropriate authorities have a wide range of experience and information on the geographical and topographical conditions found in their area of responsibility, and should be consulted during the initial design stage.

Layout of Parts 3.0 to 3.12

[Parts 3.0 to 3.12](#) of the *Housing Provisions* are organised in a manner that follows the logical construction sequence of a building. The following table outlines some of the more frequently used details and where they are located in this document.

Information guide	
Relevant part	Part reference
Earthworks	3.1.1
Fire safety	3.7.1, 3.7.2, 3.7.3 and 3.7.4
Facilities	3.8.3
Room heights	3.8.2
Light and ventilation	3.8.4 and 3.8.5
Stairway and ramp construction	3.9.1
Energy efficiency	3.12
Site preparation and drainage	3.1.3 and 3.1.4
Footings and slabs	3.2
Masonry	3.3
Framing	3.4
Roof cladding, gutters and downpipes and wall cladding	3.5
Gutters and downpipes	3.5.3
Glazing	3.6
Barriers and handrails	3.9.2
Wet areas and external waterproofing	3.8.1
Sound insulation	3.8.6
Condensation management	3.8.7
Swimming pools	3.10.1
Termite risk management	3.1.4
Earth retaining structures	3.1.2
Subfloor ventilation	3.4.1
Smoke alarms and evacuation lighting	3.7.5
Boilers, pressure vessels, heating appliances, fireplaces, chimneys and flues	3.10.7
Earthquake areas	3.10.2
Flood hazard areas	3.10.3
Construction in Bushfire areas	3.10.5
Construction in Alpine areas	3.10.4
Attachment of decks and balconies to external walls of buildings	3.10.6
High wind areas	3.0
Class 10 buildings and structures	various

Initial concept considerations	→	Earthworks Fire safety Facilities Room heights Light and ventilation Stairway and ramp construction Energy efficiency Site preparation and drainage Footings and slabs Masonry Framing Roof cladding, gutters and downpipes and wall cladding Gutters and downpipes Glazing
Construction issues	→	Barriers and handrails Wet areas and external waterproofing Sound insulation Condensation management Swimming pools Termite risk management Earth retaining structures Subfloor ventilation Smoke alarms and evacuation lighting
Special requirements	→	Boilers, pressure vessels, heating appliances, fireplaces, chimneys and flues Earthquake areas Flood hazard areas Construction in Bushfire areas Construction in Alpine areas Attachment of decks and balconies to external walls of buildings High wind areas Class 10 buildings and structures

Interpretation

Throughout Section 3, diagrams, explanatory information and cross-volume considerations are included. [A1.0](#) (interpretation) contains information on these elements and their purpose within the *Housing Provisions*.

How to use the requirements of each Part

The following is an example page layout from [Part 3.2](#). This diagram explains the concepts behind typical clauses contained throughout Section 3.

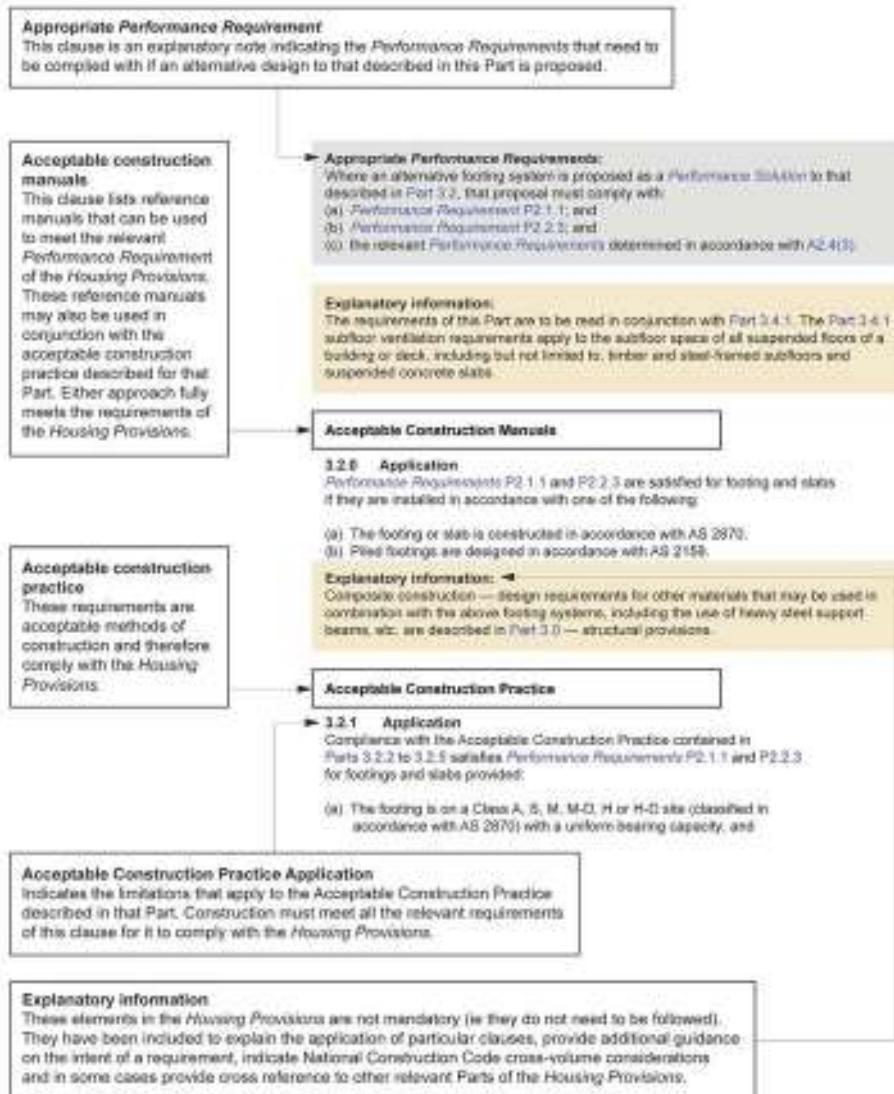

Part 3.0 Structural provisions

Appropriate *Performance Requirements*

Where it is proposed to use an alternative structural design manual as a *Performance Solution* to that described in [Part 3.0](#), that proposal must comply with—

- (a) *Performance Requirement P2.1.1*; and
- (b) the relevant *Performance Requirements* determined in accordance with [A2.2\(3\)](#) and [A2.4\(3\)](#) as applicable.

Acceptable Construction Practice

3.0.1 Application

Compliance with this acceptable construction practice satisfies *Performance Requirement P2.1.1* provided the Class 1 or Class 10 building is constructed in accordance with—

- (a) [3.0.2](#) to [3.0.5](#); or
- (b) the relevant provisions of other Parts of Section 3 of the *Housing Provisions* relating to structural elements; or
- (c) any combination thereof.

3.0.2 Resistance to actions

The resistance of a building or structure must be greater than the most critical action effect resulting from different combinations of actions, where—

- (a) the most critical action effect on a building or structure must be determined in accordance with [3.0.3](#) and the general design procedures contained in AS/NZS 1170.0; and
- (b) the resistance of a building or structure is determined in accordance with [3.0.4](#).

Explanatory information:

A building or structure must be designed to resist the most critical effect resulting from different combinations of actions, taking into consideration—

- (a) the probability of simultaneous occurrence of two or more actions; and
- (b) the levels of reliability of the structure when subject to combined actions; and
- (c) the characteristics of the action.

Determining the levels of reliability of the structure when subject to combined actions should be consistent with the levels of reliability implicit in the design events for natural phenomenon.

When designing for the maximum combined actions, a principle frequently adopted is that the maximum is likely to occur when at least one of the actions is at its maximum value.

3.0.3 Determination of individual actions

The magnitude of individual actions must be determined in accordance with the following:

- (a) Permanent actions:
 - (i) the design or known dimensions of the building or structure; and
 - (ii) the unit weight of the construction; and
 - (iii) AS/NZS 1170.1.
- (b) Imposed actions:
 - (i) the known loads that will be imposed during the occupation or use of the building or structure; and
 - (ii) *construction activity actions*; and
 - (iii) AS/NZS 1170.1.

Acceptable Construction

Explanatory information:

Permanent actions include the dead loads of the building or structure. These include the load imposed by the building's components inclusive of the forces imposed by the floors, walls, roofs, suspended ceilings, etc.

Imposed actions include live loads on the building or structure. These include the load arising from construction activity and the intended use or function of the building or structure.

- (c) Wind, snow and earthquake actions:
- (i) the applicable annual probability of design event for safety, determined by—
 - (A) assigning the building or structure an Importance Level in accordance with [Table 3.0.3a](#); and
 - (B) determining the corresponding annual probability of exceedance for safety in accordance with [Table 3.0.3b](#); and
 - (ii) for wind actions, AS/NZS 1170.2 or AS 4055; and
 - (iii) for snow and ice actions, AS/NZS 1170.3; and
 - (iv) for earthquake actions, AS 1170.4.

Explanatory information:

There are certain limitations on the application to domestic structures such as Class 1a and Class 1b buildings in Appendix A of AS 1170.4. These limitations include building height, roof slope, etc. For additional information refer to Appendix A of AS 1170.4.

State and Territory Variations

3.0.3(c)(v) is added in the Northern Territory.

- (v) Masonry veneer — Masonry veneer construction must be designed so that the structural framing to which the masonry veneer is tied will ensure the stability of the masonry veneer.

- (d) Actions not covered in (a), (b) and (c) above:
- (i) the nature of the action; and
 - (ii) the nature of the building or structure; and
 - (iii) the Importance Level of the building or structure determined in accordance with [Table 3.0.3a](#); and
 - (iv) AS/NZS 1170.1.
- (e) For the purposes of (d) the actions include but are not limited to—
- (i) liquid pressure action; and
 - (ii) ground water action; and
 - (iii) rainwater action (including ponding action); and
 - (iv) earth pressure action; and
 - (v) differential movement; and
 - (vi) time dependent effects (including creep and shrinkage); and
 - (vii) thermal effects; and
 - (viii) ground movement caused by—
 - (A) swelling, shrinkage or freezing of the subsoil; and
 - (B) landslip or subsidence; and
 - (C) siteworks associated with the building or structure; and
 - (ix) *construction activity actions*.

Table 3.0.3a Importance Levels of buildings and structures

Importance Level	Building types
1	Buildings or structures presenting a low degree of hazard to life and <i>other property</i> in the case

Acceptable Construction

Importance Level	Building types
	of failure.
2	Buildings or structures not included in Importance Level 1.

Explanatory information:

Table 3.0.3a provides a generic description of building types to which Importance Levels have been assigned. The “Importance Level” concept is applicable to building structural safety only. More specific examples are provided in the following Table. The examples are indicative and not exhaustive.

Importance Level examples

Importance Level	Examples of building types
1	Isolated minor Class 10a buildings and Class 10b structures.
2	Class 1 buildings. Class 10a buildings and Class 10b structures associated with Class 1 buildings.

Note: Importance Levels must be assigned on a case by case basis and relate to the hazards to human life and *other property* in the event of the structure’s failure. For example—

- (a) Importance Level 1 is for minor isolated structures that rarely contain people, are not required as part of normal infrastructure and present a low risk to life and *other property*.
- (b) Importance Level 2 includes domestic housing and structures intended to contain reasonable numbers of people under normal operations.

Table 3.0.3b Design events for safety—annual probability of exceedance

Importance level	Non-cyclonic wind	Cyclonic wind	Snow	Earthquake
1	1:100	1:200	1:100	1:250
2	1:500	1:500	1:150	1:500

Figure 3.0.1 Wind regions



Explanatory information:**Construction in cyclonic areas**

The intent of building construction in cyclonic areas (see [Figure 3.0.1](#)) is to ensure the structure has sufficient strength to transfer wind forces to the ground with an adequate safety margin to prevent collapse of the building and the building being lifted, or slid off its foundations.

To resist these forces it is necessary to have—

- (a) an anchorage system, where the roof is connected by the walls to the footings by a chain of connections; and
- (b) a bracing system to prevent horizontal collapse due to wind forces; and
- (c) continuity of the system where each structural element is interlocked to its adjoining structural element throughout the building.

Anchorage

Anchorage of the system is achieved by using a variety of connectors. Each connector must be capable of carrying the uplift force, because the ability of the building to resist the wind forces is directly related to its weakest link.

Acceptable construction manuals to achieve these requirements are described in this Part.

3.0.4 Determination of structural resistance of materials and forms of construction

The following requirements, or any combination of them, must be used to determine the structural resistance of materials and forms of construction as appropriate:

- (a) Earthworks: [Part 3.1](#).
- (b) Earth retaining structures: [Part 3.1](#).
- (c) Termite risk management: [Part 3.1](#).
- (d) Concrete construction (including slabs and footings, piled footings and reinforced and prestressed concrete structures): [Part 3.2](#) or AS 3600 as applicable.
- (e) Post-installed and cast-in fastenings in concrete: AS 5216.
- (f) Masonry (including masonry veneer, *unreinforced masonry* and *reinforced masonry*): [Part 3.3](#).
- (g) Steel construction (including steel framing and structural steel members): [Part 3.4](#).
- (h) Timber construction (including design of timber structures, timber framing and design of nail-plated timber roof trusses): [Part 3.4](#).
- (i) Composite steel and concrete: AS/NZS 2327.
- (j) Aluminium construction:
 - (i) AS/NZS 1664.1.
 - (ii) AS/NZS 1664.2.
- (k) Roof construction (including plastic sheeting, roofing tiles, metal roofing and terracotta, fibre-cement and timber slates and shingles): [Part 3.5](#).
- (l) Wall cladding: [Part 3.5](#).
- (m) Glazed assemblies: [Part 3.6](#).
- (n) Barriers and handrails (including stairway and ramp construction):
 - (i) [Part 3.9](#); and
 - (ii) AS/NZS 1170.1 for the determination of loading forces on a barrier.
- (o) Attachment of decks and balconies to *external walls* of buildings: [Part 3.10](#).
- (p) Garage doors and other large access doors in openings not more than 3 m in height in *external walls* of buildings determined as being located in wind region C or D in accordance with [Figure 3.0.1](#): AS/NZS 4505.
- (q) For *high wind areas*: requirements listed in [3.0.4](#) as appropriate or the Northern Territory Deemed to Comply Standards Manual.

Explanatory information:

Acceptable Construction

The weight of roof or ceiling insulation, particularly if additional ceiling insulation is used for compliance with the energy efficiency provisions, needs to be considered in the selection of plasterboard, plasterboard fixings and building framing.

3.0.5 Structural software

- (a) Structural software used in computer aided design of a building or structure, that uses design criteria based on the *Deemed-to-Satisfy Provisions* of the *Housing Provisions*, including its referenced documents, for the design of steel or timber trussed roof and floor systems and framed building systems, must comply with the ABCB Protocol for Structural Software.
- (b) The requirements of (a) only apply to structural software used to design steel or timber trussed roof and floor systems and framed building systems for buildings within the following geometrical limits:
 - (i) The distance from ground level to the underside of eaves must not exceed 6 m.
 - (ii) The distance from ground level to the highest point of the roof, neglecting chimneys, must not exceed 8.5 m.
 - (iii) The building width including roofed verandahs, excluding eaves, must not exceed 16 m.
 - (iv) The building length must not exceed five times the building width.
 - (v) The roof pitch must not exceed 35 degrees.
- (c) The requirements of (a) do not apply to design software for individual frame members such as electronic tables similar to those provided in—
 - (i) AS 1684 Parts 2, 3 and 4; or
 - (ii) NASH Standard Residential and Low-Rise Steel Framing, Part 2.

Explanatory information:

3.0.5 does not apply where a software package simply eliminates manual calculations and the process of the package requires identical methodology as that undertaken manually, e.g. AS 1684 span tables and bracing calculations.

Part **3.1**

Site Preparation

- Part 3.1** **Site preparation**
- Part 3.1.1** **Earthworks**
- Part 3.1.2** **Earth retaining structures**
- Part 3.1.3** **Drainage**
- Part 3.1.4** **Termite risk management**

Part 3.1 Site Preparation

Part 3.1 Site preparation

Part 3.1.1 Earthworks

Acceptable Construction Practice

3.1.1.0 Application

3.1.1.1 Un-retained bulk earthworks — site cut

3.1.1.2 Un-retained bulk earthworks — fill

Part 3.1.2 Earth retaining structures

Acceptable Construction Manual

3.1.2.0

Part 3.1.3 Drainage

Acceptable Construction Manual

3.1.3.0 Application

Acceptable Construction Practice

3.1.3.1 Application

3.1.3.2 Drainage requirements

3.1.3.3 Surface water drainage

3.1.3.4 Subsoil drainage

3.1.3.5 Stormwater drainage

Part 3.1.4 Termite risk management

Acceptable Construction Practice

3.1.4.1 Application

3.1.4.2 Requirements for termite management systems

3.1.4.3 Termite management systems

3.1.4.4 Durable notice

Part 3.1 Site preparation

Explanatory information:

These provisions relate to general *site* preparation for footings, services, drainage and installation of termite management systems. It should be noted that other construction methods may be used to achieve the same results as specified in this Part provided they comply with the appropriate *Performance Requirement*.

Part 3.1.1 Earthworks

Appropriate *Performance Requirement*:

Where an alternative approach to earthworks is proposed as a *Performance Solution* to that described in [Part 3.1.1](#), that proposal must comply with—

- (a) *Performance Requirement P2.1.1*; and
- (b) the relevant *Performance Requirements* determined in accordance with [A2.2\(3\)](#) and [A2.4\(3\)](#) as applicable.

Explanatory information:

The provisions in [Part 3.1.1](#) will enable earthworks associated with the construction of a building to be carried out safely and to avoid potential damage to the subject building, adjoining structures and property through the soil collapsing or subsiding. Exceptional *site* conditions (including the effects of torrential rain) may need special consideration and additional advice from appropriately qualified people should be considered.

State and Territory legislation may also have requirements that apply to earthworks, especially in relation to adjoining property and notification of owners of that property. Advice should be obtained from the *appropriate authority* before commencement of works.

The requirements of this Part are to be read in conjunction with [Part 3.1.2](#) where an earth retaining structure is installed.

State and Territory Variations

Except for [Table 3.1.1.1](#) as referenced by [Figure 3.1.3.1](#) and except for [Clause 3.1.1.0\(a\)](#) for determination of a normal site as referenced by [Clause 3.2.1](#), [Part 3.1.1](#) does not apply in New South Wales.

Note: In New South Wales requirements for shoring and adequacy of excavation works are a prescribed condition of development consent. In addition consent authorities can place specific controls on siteworks associated with the construction of a building, by imposing further conditions of development consent. Information addressing siteworks can be found in the Department of Planning and Environment – Act and Regulation note “Health, safety and amenity during construction”.

Acceptable Construction Practice

3.1.1.0 Application

Compliance with this acceptable construction practice satisfies *Performance Requirement P2.1.1* for earthworks associated with the construction of a building or structure provided—

- (a) the *site* is classified as A, S, M, H or E in accordance with [Part 3.2.4](#) and the work is undertaken in normal *site* conditions; and
- (b) un-retained bulk earthworks are undertaken in accordance with [3.1.1.1](#) and [3.1.1.2](#); and

Explanatory information:

“Normal” *site* conditions relates to parameters such as—

- the *site* conditions not being significantly modified by the removal of previous buildings or other structures; and
- the moisture conditions on *site* being as a result of seasonal and climatic changes; and
- the *site* conditions not being subject to unusual moisture conditions caused by drains, dams, channels, ponds or tanks which are to be maintained or removed; and
- large trees have not been recently removed from the *site* in the area where the building is to be constructed; and
- other similar matters.

Further information regarding normal and abnormal *site* conditions can be found in AS 2870.

Site Preparation

Table 3.1.1.1 Un-retained embankment slope ratios

Soil class (see Part 3.2.4 for material description)	Site cut (excavation) (maximum embankment slope ratio, angle of site cut H:L ^{Note 1})	Compacted fill (maximum embankment slope ratio, angle of batter H:L ^{Note 1})
Stable rock (Class A)	8:1	2:3
Sand (Class A)	1:2	1:2
Firm clay (Class M-E)	1:1	1:2
Soft clay (Class M-E)	2:3	Not suitable

Notes to Table 3.1.1.1:

1. See Figure 3.1.1.1 for some examples of un-retained embankment slopes.
2. Retaining walls must be installed in accordance with Part 3.1.2 where—
 - a. the embankment slope is steeper than described in this Table; or
 - b. the soil type is not described in this Table.

Figure 3.1.1.1a Site cut and fill using un-retained embankments - Site cut commencing at the allotment boundary or affecting an adjoining property

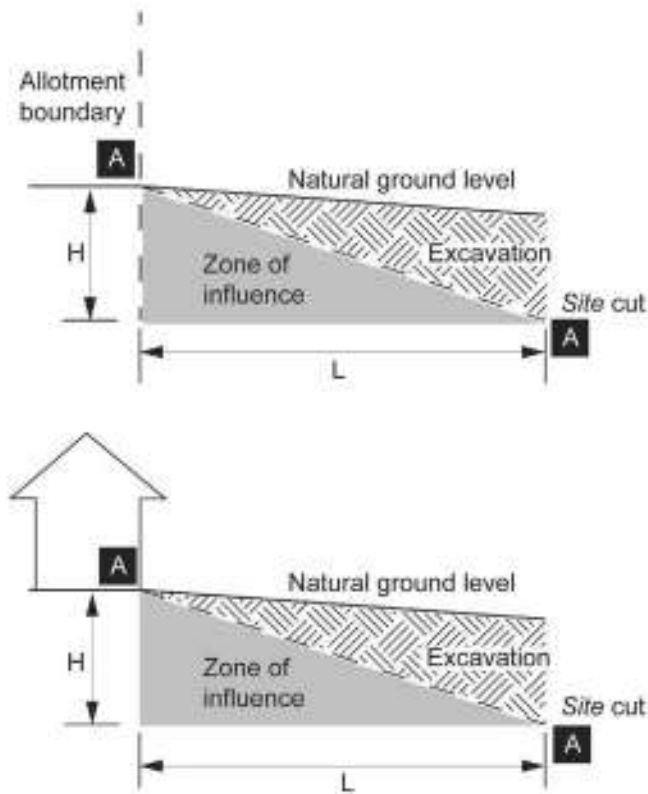

Site Preparation

Figure 3.1.1.1b Site cut and fill using un-retained embankments - Fill commencing at the allotment boundary or affecting an adjoining property

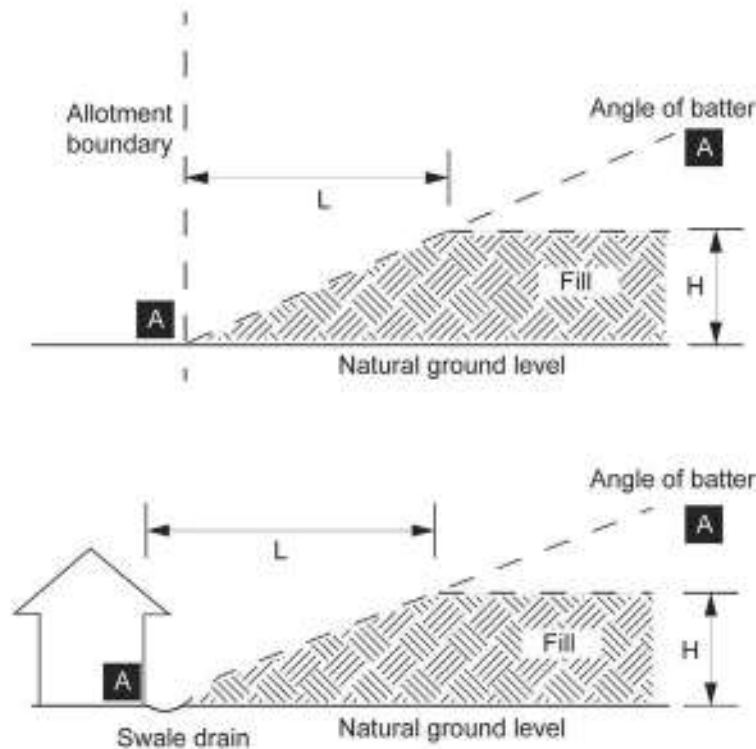

Notes to Figure 3.1.1.1b:

1. The angle for line A-A is defined as the maximum embankment slope ratio H:L in Table 3.1.1.1 and is taken from the bottom of the existing footing and is defined as the area suitable for excavation.
2. Consideration must be given for drainage of *surface water*, particularly where fill affects an adjoining property.

3.1.1.1 Un-retained bulk earthworks — site cut

A *site* cut using an un-retained embankment must be—

- (a) within the allotment; and
- (b) not within the zone of influence of any existing structure on the property, or the allotment boundary as defined in Table 3.1.1.1 and Figure 3.1.1.1a; and
- (c) not deeper than 2 m from the natural ground level at any point.

3.1.1.2 Un-retained bulk earthworks — fill

Fill, using an un-retained embankment must—

- (a) be placed within the allotment; and
- (b) be placed at a gradient which complies with Table 3.1.1.1 and Figure 3.1.1.1b; and
- (c) be placed and mechanically compacted in layers not more than 150 mm; and
- (d) be not more than 2 m in height from the natural ground level at any point; and
- (e) where used to support footings or slabs, be placed and compacted in accordance with Part 3.2; and
- (f) have *surface water* diverted away from any existing structure on the property or adjoining allotment in accordance with 3.1.3.3.

Part 3.1.2 Earth retaining structures

Appropriate *Performance Requirements*:

Where an alternative earth retaining structure design is proposed as a *Performance Solution* to that described in [Part 3.1.2](#), that proposal must comply with—

- (a) *Performance Requirement P2.1.1*; and
- (b) The relevant *Performance Requirements* determined in accordance with [A2.2\(3\)](#) and [A2.4\(3\)](#) as applicable.

Acceptable Construction Manual

3.1.2.0

Performance Requirement P2.1.1 is satisfied for an earth retaining structure associated with the construction of a building or structure if it is designed and constructed in accordance with AS 4678.

Explanatory information:

AS 4678 contains requirements for earth retaining structures between 800 mm and 15 m in height, and does not apply to structures which are founded in exceptional *site* conditions (e.g. landslips), are subjected to sustained cyclic loading or are used for the purposes of water-retaining (e.g. dams and reservoirs).

It should be noted that [3.1.2.0](#) is only one way of achieving compliance with [P2.1.1](#). Other ways of complying include the following:

- (a) The relevant structural design manuals in [Part 3.0](#).
- (b) The relevant provisions of other Parts of Section 3 relating to earth retaining structures.
- (c) A *Performance Solution* that uses one of the other NCC *Assessment Methods* which verifies that compliance with [P2.1.1](#) will be achieved.

Part 3.1.3 Drainage

Appropriate *Performance Requirements*

Where an alternative drainage system is proposed as a *Performance Solution* to that described in [Part 3.1.3](#), that proposal must comply with—

- (a) *Performance Requirement P2.2.1*; and
- (a) the relevant *Performance Requirements* determined in accordance with [A2.2\(3\)](#) and [A2.4\(3\)](#) as applicable.

Acceptable Construction Manual

3.1.3.0 Application

Performance Requirement P2.2.1 is satisfied for drainage if it is designed and constructed in accordance with AS/NZS 3500.3.

Acceptable Construction Practice

3.1.3.1 Application

Compliance with this acceptable construction practice satisfies *Performance Requirement P2.2.1* for drainage of—

- (a) roofs in areas subject to 5 minute duration rainfall intensities of not more than 255 mm per hour over an *average recurrence interval* of 20 years (as per [Table 3.5.2.1](#)) where a drainage system is *required*; and
- (b) sub-soil areas where excessive soil moisture problems may occur; and
- (c) land adjoining and under buildings,

provided the stormwater drainage system otherwise complies with the acceptable construction manual.

Explanatory information:

1. The BCA does not require the installation of drainage systems. Accordingly these requirements need only be applied when these systems are used.
2. Information on the need for drainage systems may be obtained from the *appropriate authority*.
3. The legal discharge point from a building *site* is generally determined by local government authorities.

3.1.3.2 Drainage requirements

Drainage systems must be installed as follows—

- (a) areas adjoining and under buildings — *surface water* drainage in accordance with [3.1.3.3](#); and
- (b) where *site* conditions exist that create a need for subsoil water to be diverted away from footings, basements, retaining walls etc — sub-soil drainage in accordance with [3.1.3.4](#); and
- (c) where underground drainage from roof areas is *required* or permitted — underground stormwater drainage in accordance with [3.1.3.5](#); and
- (d) excavation for drains adjacent to existing footings must be within the area described in [Figure 3.1.3.1](#) as being safe for excavation.

Site Preparation

Figure 3.1.3.1 Excavation for drains adjacent to footings

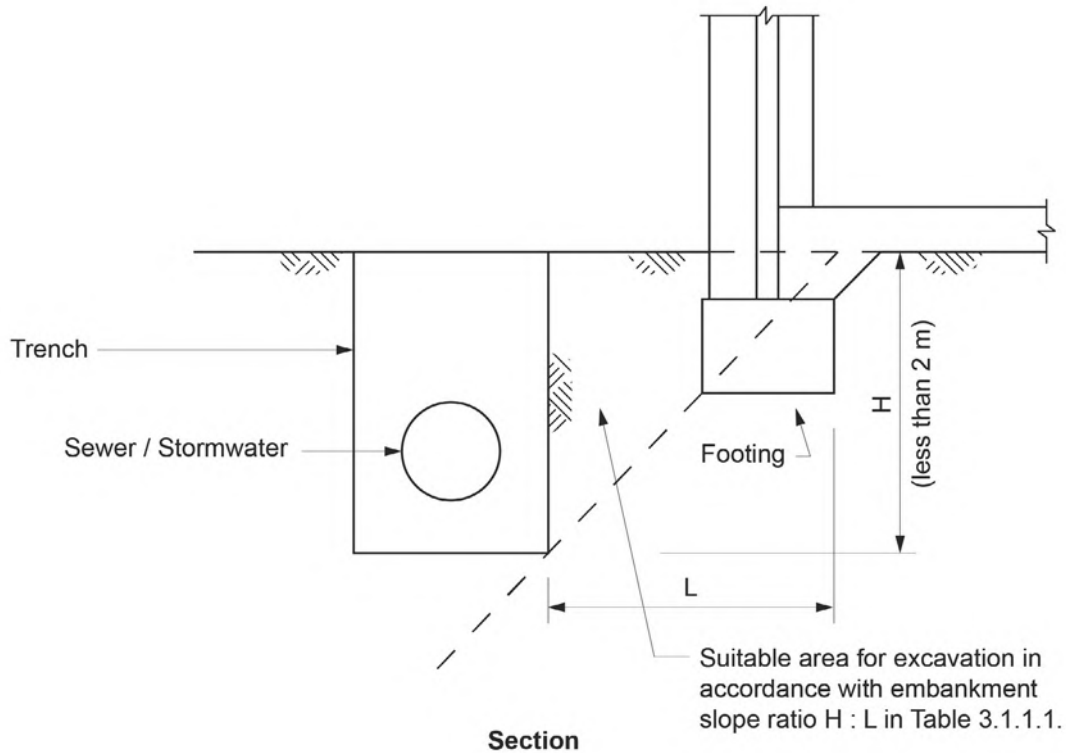

Note to Figure 3.1.3.1: Any excavation below the area defined as being safe for excavation will need additional protection measures to be determined by appropriately qualified persons.

3.1.3.3 Surface water drainage

Surface water must be diverted away from Class 1 buildings as follows:

- (a) Slab-on-ground — finished ground level adjacent to buildings:
the external finished surface surrounding the slab must be drained to move *surface water* away from the building and graded to give a slope of not less than (see Figure 3.1.2.2)—
- (i) 25 mm over the first 1 m from the building in *low rainfall intensity areas* for surfaces that are reasonably impermeable (such as concrete or clay paving); or
 - (ii) 50 mm over the first 1 m from the building in any other case.
- (b) Slab-on-ground — finished slab heights:
the height of the slab-on-ground above external finished surfaces must be not less than (see Figure 3.1.3.2)—
- (i) 100 mm above the finished ground level in *low rainfall intensity areas* or sandy, well-drained areas; or
 - (ii) 50 mm above impermeable (paved or concreted areas) that slope away from the building in accordance with (a); or
 - (iii) 150 mm in any other case.

Explanatory information:

The appropriate slab height above finished ground level and the slope of the external finished surface surrounding the slab may vary depending on:

1. The local plumbing requirements; in particular the height of the overflow relief gully relative to drainage fittings and ground level (to work effectively they must be a minimum of 150 mm below the lowest sanitary fixture).
2. The run-off from storms, particularly in areas of high rainfall intensity, and the local topography.
3. The effect of excavation on a cut and fill *site*.

Site Preparation

4. The possibility of flooding.
5. Termite risk management provisions.

Clearances between wall cladding and the finished ground level are provided in [3.5.4.7](#).

- (c) The ground beneath suspended floors must be graded so that the area beneath the building is above the adjacent external finished ground level and *surface water* is prevented from ponding under the building (see [Figure 3.1.3.3](#)).

Figure 3.1.3.2 Site surface drainage

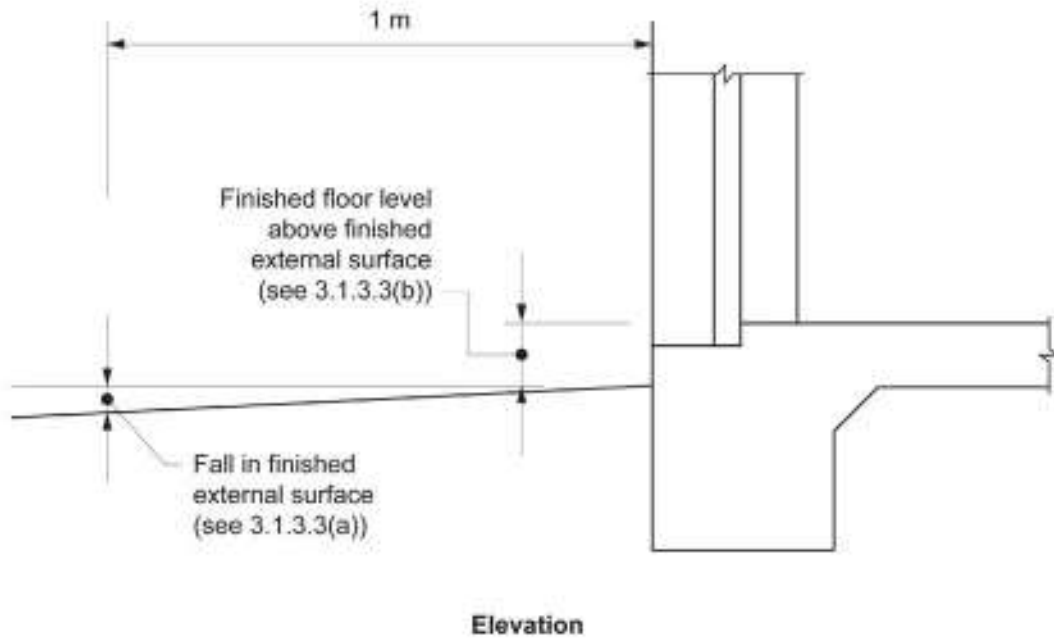
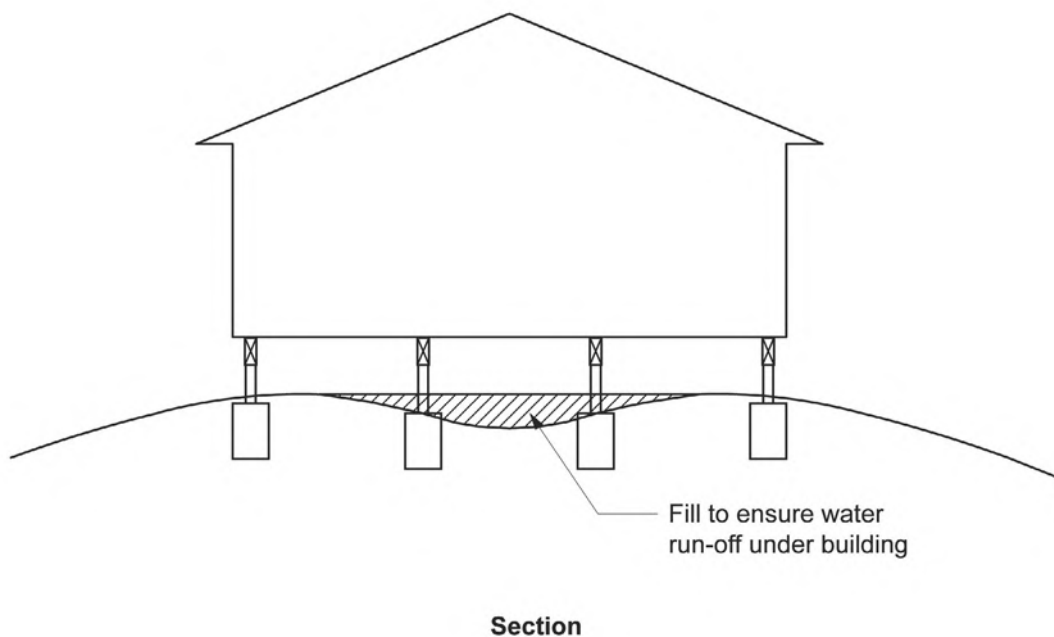

Figure 3.1.3.3 Grading of ground under suspended floors



3.1.3.4 Subsoil drainage

Where a subsoil drainage system is installed to divert subsurface water away from the area beneath a building, the subsoil drain must—

- (a) be graded with a uniform fall of not less than 1:300; and
- (b) discharge into an external silt pit or sump with—
 - (i) the level of discharge from the silt pit or sump into an impervious drainage line not less than 50 mm below the invert level of the inlet (see [Figure 3.1.3.4](#)); and
 - (ii) provision for cleaning and maintenance.

Figure 3.1.3.4 Construction of silt pits

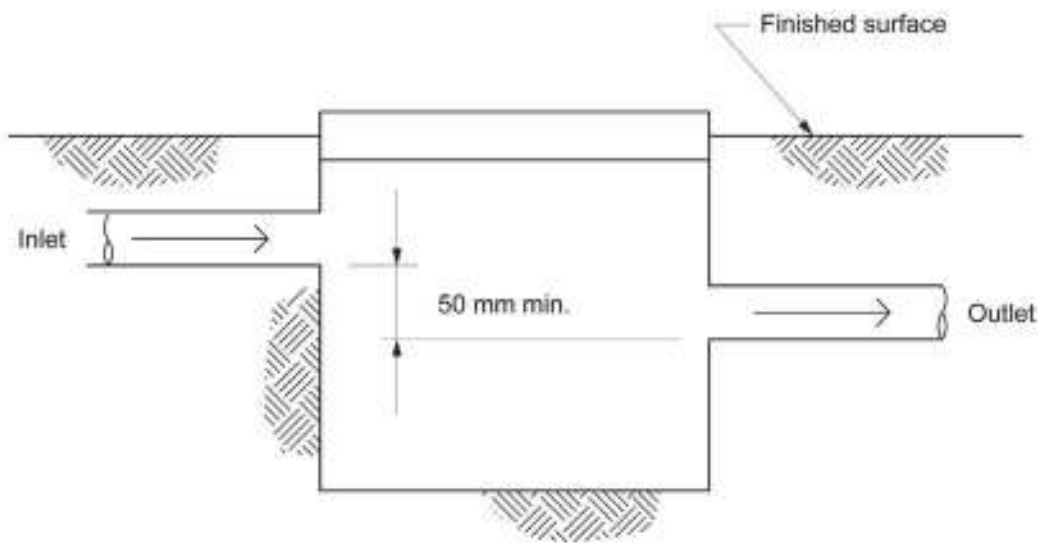

Explanatory information:

Subsoil drainage systems may need to be installed where subsurface water movement could damage buildings or cause loss of amenity through the build up of excessive moisture or lateral water pressure. Typical locations of subsoil drainage systems are on the uphill side of cut and fill sites, adjacent to deep footings, behind retaining walls and adjacent to basement walls.

The design and installation of subsoil drainage systems should take into account the nature of the soil and the anticipated water level, quantity and movement. In some cases, detailed investigations involving excavations, field observations and soil tests may be necessary to determine the appropriate solution. Typical subsoil drain configurations are shown in the following diagrams.

In clay soil, subsoil drains can alter the long-term moisture content in the soil, adversely affecting the building foundation by removing or, in some cases, introducing water. In such conditions, subsoil drains should only be used where there are no other options for dealing with subsoil water.

Additional guidance on subsoil drainage systems can be found in AS/NZS 3500.3 and AS 2870.

Site Preparation

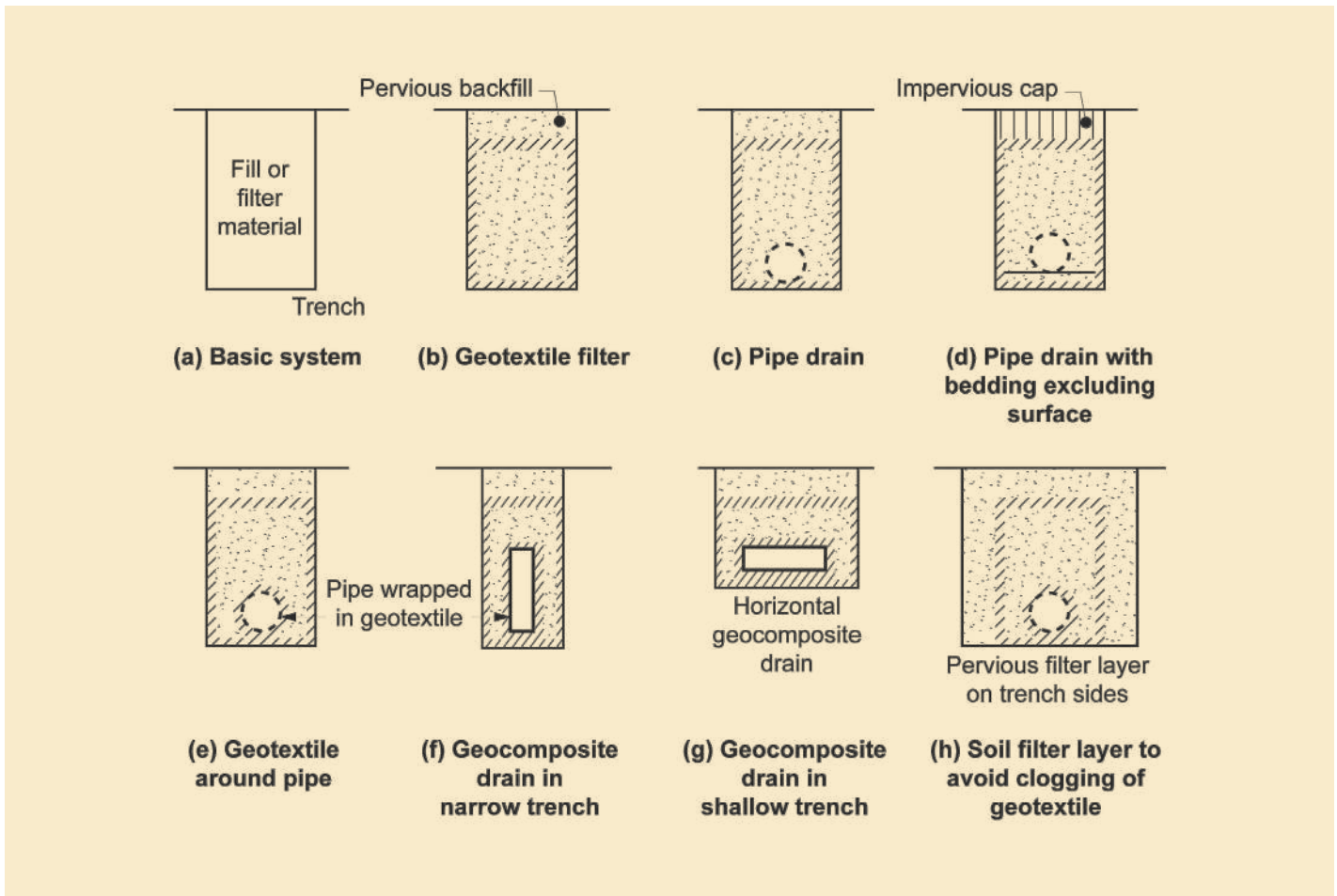

3.1.3.5 Stormwater drainage

Where a stormwater drainage system is installed, it must comply with the following:

- (a) The position and manner of discharge of the stormwater drainage system must be to the satisfaction of the *appropriate authority*.
- (b) The stormwater drainage system must be designed so that any overflow during heavy rain periods is prevented from flowing back into the building.

Explanatory information:

The manner of discharge of stormwater drainage systems includes consideration of discharge points. Some examples of discharge points which may be acceptable to the *appropriate authority* are:

- (a) A legal discharge point at the allotment boundary.
 - (b) On-site catchment systems, such as stormwater tanks.
 - (c) On-site soil drainage systems, such as soaker wells.
- (c) Cover to stormwater drains:
the cover to 90 mm Class 6 UPVC stormwater drains installed underground must be not less than—
- (i) under soil — 100 mm; or
 - (ii) under paved or concrete areas — 50 mm; or
 - (iii) under areas subject to light vehicle traffic—
 - (A) reinforced concrete — 75 mm; or
 - (B) paved — 100 mm.

Explanatory information:

Different depths of soil cover (or no cover at all) can be achieved using other types of pipes. The cover specified is

Site Preparation

measured from the top of the pipe to either the finished ground level or, in the case of paved or concreted areas, to the underside of the paving or concrete.

Part 3.1.4 Termite risk management

Appropriate *Performance Requirements*

Where an alternative termite management system is proposed as a *Performance Solution* to that described in [Part 3.1.4](#), that proposal must comply with—

- (a) *Performance Requirement P2.1.1*; and
- (b) the relevant *Performance Requirements* determined in accordance with [A2.2\(3\)](#) and [A2.4\(3\)](#) as applicable.

Acceptable Construction Practice

3.1.4.1 Application

Compliance with this acceptable construction practice satisfies *Performance Requirement P2.1.1* for termite risk management.

Explanatory information:

The intent of these requirements is to provide for a termite management system that deters termites from gaining entry to a building via a concealed route. The installation of a termite management system will not stop termite activity from occurring on the *site*.

State and Territory Variations

In Queensland delete 3.1.4.1 and replace with the following:

3.1.4.1 Application

Compliance with this acceptable construction practice satisfies *Performance Requirements P2.1.1* and [QLD P2.1.3](#).

3.1.4.2 Requirements for termite management systems

- (a) The requirements of this Part apply where:
 - (i) a Class 1 or 10 building is constructed in an area where subterranean termites are known to present a potential risk of attack; and
 - (ii) a *primary building element* of a Class 1 or 10 building is considered susceptible to termite attack.
- (b) For the purposes of (a), a *primary building element* consisting entirely of, or a combination of, any of the following materials is considered not subject to termite attack:
 - (i) Steel, aluminium or other metals.
 - (ii) Concrete.
 - (iii) Masonry.
 - (iv) Fibre-reinforced cement.
 - (v) Timber — naturally termite resistant in accordance with Appendix C of AS 3660.1.
 - (vi) Timber — preservative treated in accordance with Appendix D of AS 3660.1.

Explanatory information:

1. [3.1.4.2\(a\)](#): Termites are not considered to be a risk in Tasmania and a lesser risk in parts of Victoria. The *appropriate authority* may have records of termite activity for each area and may be able to advise on whether termite risk management is needed.
2. [3.1.4.2\(b\)](#): Where individual *primary building elements* are susceptible to termite attack and the remainder of the *primary building elements* are constructed of termite resistant materials, only the susceptible elements need to be provided with a termite management system.
3. [3.1.4.2\(b\)\(iii\)](#): states that masonry is not subject to termite attack, however termites may gain entry through mortar and other joints.

Site Preparation

Figure 3.1.4.1 Flow chart for identifying if a termite management system is required

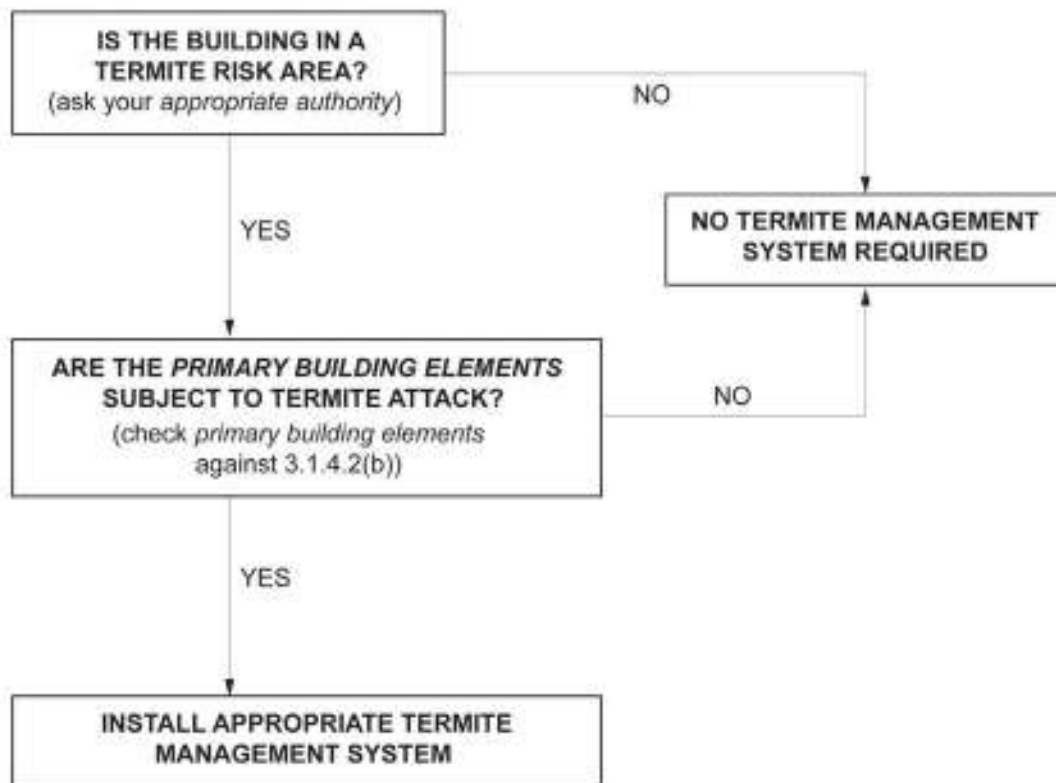

State and Territory Variations

In Northern Territory delete 3.1.4.2(b)(v) and replace with the following:

(v) Timber — naturally termite resistant timber in accordance with Appendix C of AS 3660.1 in areas where *Mastotermes darwiniensis* are not prevalent.

State and Territory Variations

In Queensland delete 3.1.4.2 and replace with the following:

3.1.4.2 Requirements for termite management systems

- (a) The requirements of this Part apply where:
- (i) a Class 1 or 10 building is constructed in an area where subterranean termites are known to present a potential risk of attack; and
 - (ii) a *primary building element* of a Class 1 or 10 building is considered susceptible to termite attack.
- (b) For the purposes of (a), a *primary building element* consisting entirely of, or a combination of, any of the following materials is considered not subject to termite attack:
- (i) Steel, aluminium or other metals.
 - (ii) Concrete.
 - (iii) Masonry.
 - (iv) Fibre-reinforced cement.
 - (v) Timber — naturally termite resistant in accordance with Appendix C of AS 3660.1.
 - (vi) Timber — preservative treated in accordance with Appendix D of AS 3660.1.
- (c) A termite management system installed in a Class 1 or 10 building to minimise the risk of termite attack to *primary building elements* shall be in accordance with clause 3.1.4.3.
- (d) The termite management system required by (c) must have—
- (i) for a non-temporary Class 1 building, a design life of at least 50 years; or
 - (ii) for other than a non-temporary Class 1 building, a design life of at least 50 years or the specified design life

Site Preparation

of the building, whichever is the lesser.

- (e) A termite management system need not comply with (d) if it is easily and readily accessible for replenishment or replacement and is capable of being replenished or replaced.
- (f) Where a chemical is used as an external perimeter termite management system, it must be—
 - (i) installed by excavating trenches, treating the exposed trench and backfilling the trench with treated material; and
 - (ii) covered by a concrete cover strip not less than 50 mm thick and 300 mm wide measured from the external wall of the building.

3.1.4.3 Termite management systems

Where a termite management system is *required* it must—

- (a) be selected appropriate to [Table 3.1.4.1](#); and
- (b) comply with—
 - (i) AS 3660.1; or
 - (ii) have been tested and passed the tests required by Section 5 of AS 3660.3; and
- (c) have a durable notice installed in accordance with [3.1.4.4](#); and
- (d) where a chemical termite management system is used, the chemical must be included on the *appropriate authority's* pesticides register.

Explanatory information:

[3.1.4.3\(b\)\(ii\)](#) provides the option of having a chemical termite management system tested to AS 3660.3. In order for the test results to remain valid, the system would then have to be installed as tested.

State and Territory Variations

In the Northern Territory delete 3.1.4.3(d) and insert 3.1.4.3(d) and (e) as follows:

- (d) include additional termite risk management measures in areas where *Mastotermes darwiniensis* are prevalent; and
- (e) where a chemical termite management system is used—
 - (i) the chemical must be included on the *appropriate authority's* pesticides register; and
 - (ii) when used as an external perimeter termite management system for *Mastotermes darwiniensis*, it is—
 - (A) installed by excavating trenches, treating the exposed trench and backfilling the trench with treated material; and
 - (B) covered by a concrete cover strip not less than 50 mm thick and 300 mm wide measured from the external wall of the building.

State and Territory Variations

In Queensland delete 3.1.4.3 and replace with the following:

3.1.4.3 Termite management systems

Where a termite management system is *required* it must—

- (a) be selected appropriate to [QLD Table 3.1.4.1](#); and
- (b) comply with—
 - (i) AS 3660.1 subject to clause [3.1.4.2\(d\)](#), (e) and (f); or
 - (ii) have been tested and passed the test results required by Section 5 of AS 3660.3; and
- (c) have a durable notice installed in accordance with [3.1.4.4](#); and
- (d) where a chemical termite management system is used, the chemical must be included on the *appropriate authority's* pesticides register.

3.1.4.4 Durable notice

A durable notice must be permanently fixed to the building in a prominent location, such as in a meter box or the like,

Site Preparation

indicating—

- (a) the termite management system used; and
- (b) the date of installation of the system; and
- (c) where a chemical is used, its life expectancy as listed on the *appropriate authority's* register label; and
- (d) the installer's or manufacturer's recommendations for the scope and frequency of future inspections of termite activity.

Explanatory information:

1. Appropriate authority

For the purpose of the pesticides register, the *appropriate authority* is the government body responsible for the registration of pesticides. Currently, the Australian Pesticides and Veterinary Medicines Authority (APMVA) coordinates the registration scheme.

2. Durable notice

Where a durable notice is *required* by 3.1.4.3 a durable notice must be fixed to the building in a prominent location advising the building occupants that the system should be inspected and maintained.

The notice should be clearly written, on a material that will not deteriorate or fade over time and be located in or near the electrical meter box or similar location so that it can be easily seen and read by future owners of the building. Additional information may be included if desired by the person placing the notice.

Table 3.1.4.1 Acceptable termite management systems and components

Building element	Termite management system or component options
Concrete slab-on-ground: Slab perimeter or <i>external wall</i> perimeter	Slab edge exposure Sheet material Granular material Chemical
Concrete slab-on-ground: Penetrations/control joints/area beneath the slab (see Note)	Sheet material Granular material Chemical
Suspended floors	Sheet material Granular material Chemical
Attachments to buildings	Termite management system to the attachment Inspection zone between attachment and building

Note to Table 3.1.4.1: The entire area beneath the slab must be treated when the slab-on-ground is not designed and constructed in accordance with AS 2870 or AS 3600.

Explanatory information:

1. Component

A component of a system as referred to in Table 3.1.4.1 is one that when used in combination with other components, will form a "full system".

For example, if a concrete slab is used as a component of a system, it in itself will not provide a complete termite management system. Depending on the construction methods and the *site* conditions, additional requirements will be necessary for service penetrations through the concrete slab. Each of these are "components", when integrated, will form a "full system".

2. Integrity of the termite management system

There are more than 350 species of termites in Australia, about 30 of which achieve economic importance by causing costly damage to building structures. Due to the nature of termites, it is extremely difficult to prevent them gaining access to a building.

In addition to correct installation of a termite management system, its effectiveness will rely on regular maintenance and competent inspection.

3. Attachments to buildings

Site Preparation

Attachments referred to in [Table 3.1.4.1](#) include downpipes, service pipes, steps, verandahs, porches, access ramps, carports, trellises, decks, heated water systems, airconditioners and the like.

State and Territory Variations

In Queensland delete [Table 3.1.4.1](#) and replace with the following:

Table 3.1.4.1 Acceptable termite management systems and components (as per AS 3660.1)

Footing system	Slab edge exposure	Termite shielding	Stainless steel mesh	Graded stone	Chemicals
Concrete slab-on-ground complying with AS 2870: Penetrations and control joints	Not suitable	Not suitable	Component; or full system subject to 3.1.4.2(d)	Component; or full system subject to 3.1.4.2(d)	Full system beneath slab subject to 3.1.4.2(d) and (e)
Concrete slab-on-ground complying with AS 2870: Slab perimeter	Suitable subject to 3.1.4.2(d)	Not suitable	Component; or full system subject to 3.1.4.2(d)	Component; or full system subject to 3.1.4.2(d)	Perimeter system subject to 3.1.4.2(d) and (f)
Concrete slab-on-ground not complying with AS 2870: Beneath slab (includes penetrations and control joints)	Not suitable	Not suitable	Full system subject to 3.1.4.2(d)	Full system subject to 3.1.4.2(d)	Full system beneath slab subject to 3.1.4.2(d) and (e)
Concrete slab-on-ground not complying with AS 2870: Slab perimeter	Suitable subject to 3.1.4.2(d)	Not suitable	Full system subject to 3.1.4.2(d)	Full system subject to 3.1.4.2(d)	Perimeter system subject to 3.1.4.2(d) and (f)
Suspended floors	Not applicable	Suitable subject to 3.1.4.2(d)	Suitable subject to 3.1.4.2(d)	Component; or full system subject to 3.1.4.2(d)	Full system subject to 3.1.4.2(d) and (e)

Footings and Slabs

- Part 3.2** **Footings and slabs**
- Part 3.2.2** **Preparation**
- Part 3.2.3** **Concrete and reinforcing**
- Part 3.2.4** **Site classification**
- Part 3.2.5** **Footing and slab construction**

Part 3.2 Footings and Slabs

Part 3.2 Footings and slabs

Acceptable Construction Manuals

3.2.0 Application

Acceptable Construction Practice

3.2.1 Application

Part 3.2.2 Preparation

3.2.2.1 Excavation for footings

3.2.2.2 Filling under concrete slabs

3.2.2.3 Foundations for footings and slabs

3.2.2.4 Slab edge support on sloping sites

3.2.2.5 Stepped footings

3.2.2.6 Vapour barriers

3.2.2.7 Edge rebates

Part 3.2.3 Concrete and reinforcing

3.2.3.1 Concrete

3.2.3.2 Steel reinforcement

Part 3.2.4 Site classification

3.2.4.1 Site classification

Part 3.2.5 Footing and slab construction

3.2.5.1 Footing and slab construction

3.2.5.2 Footings and slabs to extensions to existing buildings

3.2.5.3 Shrinkage control

3.2.5.4 Minimum edge beam dimensions

3.2.5.5 Footings for fireplaces on Class A and S sites

3.2.5.6 Stump footing details

Part 3.2 Footings and slabs

Explanatory information:

This Part specifies the requirements for the excavation and filling for the footing or slab together with the construction of various alternative concrete slab and footing configurations. The slab and footing configurations detailed in [Part 3.2.5](#) are only suitable for the specified soil classifications. The requirements contained in the remainder of this Part are more general and may be applied to all slab and footing construction.

Appropriate *Performance Requirements*

Where an alternative footing system is proposed as a *Performance Solution* to that described in [Part 3.2](#), that proposal must comply with—

- (a) *Performance Requirement P2.1.1*; and
- (b) *Performance Requirement P2.2.3*; and
- (c) the relevant *Performance Requirements* determined in accordance with [A2.2\(3\)](#) and [A2.4\(3\)](#) as applicable.

Explanatory information:

The requirements of this Part are to be read in conjunction with [Part 3.4.1](#). The [Part 3.4.1](#) subfloor ventilation requirements apply to the subfloor space of all suspended floors of a building or deck, including but not limited to, timber and steel-framed subfloors and suspended concrete slabs.

Acceptable Construction Manuals

3.2.0 Application

Performance Requirements P2.1.1 and *P2.2.3* are satisfied for footings and slabs if they are installed in accordance with one of the following:

- (a) The footing or slab is constructed in accordance with AS 2870.
- (b) Piled footings are designed in accordance with AS 2159.

Explanatory information:

Composite construction — design requirements for other materials that may be used in combination with the above footing systems, including the use of heavy steel support beams, etc. are described in [Part 3.0](#) — structural provisions.

State and Territory Variations

In New South Wales delete 3.2.0(a) and insert NSW 3.2.0(a) as follows:

- (a) The footing or slab is constructed in accordance with AS 2870 except that for the purposes of Clause 5.3.3.1 of AS 2870 a damp-proofing membrane is required to be provided.

Acceptable Construction Practice

3.2.1 Application

Compliance with the acceptable construction practice contained in [Parts 3.2.2](#) to [3.2.5](#) satisfies *Performance Requirements P2.1.1* and *P2.2.3* for footings and slabs, provided—

- (a) the footing is on a Class A, S, M, M-D, H or H-D *site* (classified in accordance with AS 2870) with a uniform bearing capacity; and
- (b) the slab is not more than 30 m long; and
- (c) slabs containing permanent joints (eg construction joints) are not used; and
- (d) the structure supported by the footing does not contain—
 - (i) more than two trafficable floors; or

Footings and Slabs

- (ii) a wall height exceeding 8 m, excluding any gable; and
- (e) the footing does not support more than one concrete slab; and

Explanatory information:

For the purpose of (e) split level slabs are considered as one slab.

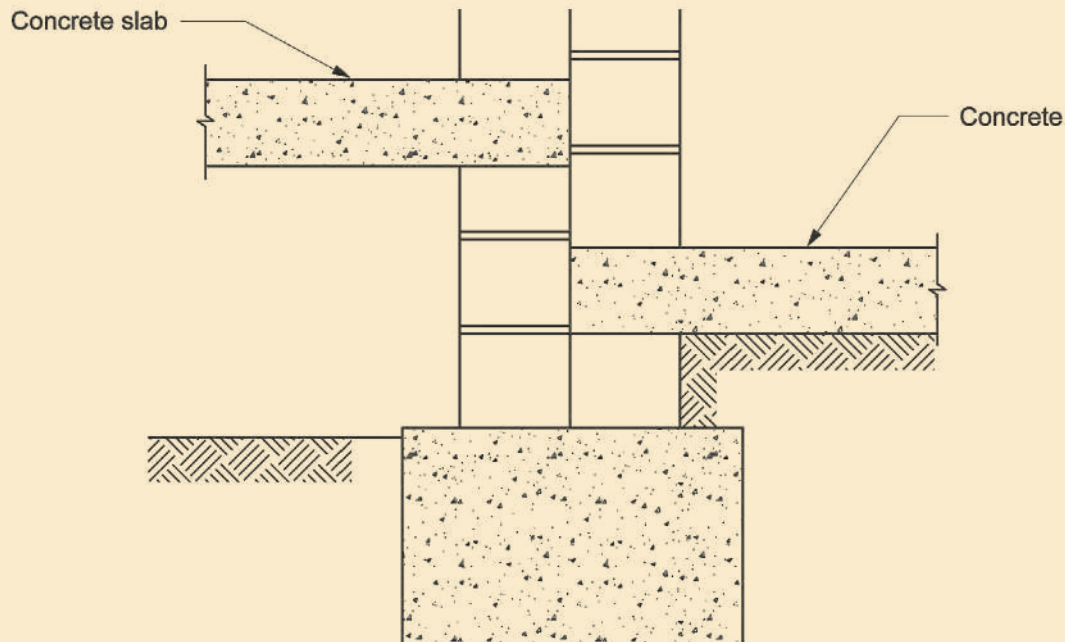

Diagram 1 — Split level concrete slab

- (f) the building does not include wing walls or masonry arches not detailed for movement in accordance with Cement Concrete and Aggregates Australia TN 61; and
- (g) single leaf earth or stone masonry walls do not exceed 3 m in height; and
- (h) the *site* is considered to be normal as defined in [Part 3.1.1](#); and
- (i) the *site* is not located in an *alpine area*.

Part 3.2.2 Preparation

3.2.2.1 Excavation for footings

- (a) Excavation for footings, including thickenings for slabs and pads must be clean cut with vertical sides, wherever possible.
- (b) The base of the excavation must be—
 - (i) for flat *sites*, generally level but may slope not more than 1:40 to allow excavations to drain; and
 - (ii) sloping *sites* at an angle of not more than 1:10; and
 - (iii) stepped footings in accordance with 3.2.2.5.
- (c) Footing excavations must be free of loose earth, tree roots, mud or debris immediately before pouring concrete.
- (d) Topsoil containing grass roots must be removed from the area on which the footing will rest.
- (e) Excavation depths and soil cuts must comply with Part 3.1.1.

State and Territory Variations

3.2.2.1(e) does not apply in New South Wales.

Note: In New South Wales requirements for shoring and adequacy of excavation works are a prescribed condition of development consent. In addition consent authorities can place specific controls on siteworks associated with the construction of a building, by imposing further conditions of development consent. Information addressing siteworks can be found in the Department of Planning and Environment – Act and Regulation note “Health, safety and amenity during construction”.

- (f) On loose sand *sites* or *sites* subject to wind or water erosion, the depth below *finished ground level* for footings must be not less than 300 mm.
- (g) Height of finished slab-on-ground must be in accordance with 3.1.3.3(b).

3.2.2.2 Filling under concrete slabs

Filling placed under a slab (except where the slab is suspended) must comply with the following:

- (a) Filling must be either *controlled fill* or *rolled fill* as follows:
 - (i) Sand used in *controlled fill* or *rolled fill* must not contain any gravel size material and achieve a blow count of 7 or more per 300 mm using the test method described in AS 1289.6.3.3.
 - (ii) Clay used in *controlled fill* or *rolled fill* must be moist during compaction.
 - (iii) *Controlled fill*:
 - (A) Sand fill up to 800 mm deep — well compacted in layers not more than 300 mm deep by vibrating plate or vibrating roller.
 - (B) Clay fill up to 400 mm deep — well compacted in layers of not more than 150 mm by a mechanical roller.
 - (iv) *Rolled fill*:
 - (A) Sand fill up to 600 mm deep — compacted in layers of not more than 300 mm by repeated rolling by an excavator or other suitable mechanical equipment.
 - (B) Clay fill up to 300 mm deep — compacted in layers of not more than 150 mm by repeated rolling by an excavator or similar machine.
- (b) * * * * *
- (c) A level layer of clean quarry sand must be placed on top of the fill, with a depth of not less than 20 mm.
- (d) A graded stone termite management system complying with Part 3.1.4 may be substituted for the sand *required* in (c).

3.2.2.3 Foundations for footings and slabs

Footings and slabs, including internal and edge beams, must be founded on soil with an allowable bearing pressure as follows:

- (a) Slab panels, load support panels and internal beams — natural soil with an allowable bearing pressure of not less than 50 kPa or *controlled fill* or *rolled fill* compacted in accordance with 3.2.2.2.
- (b) Edge beams connected to the slab — natural soil with an allowable bearing pressure of not less than 50 kPa or *controlled fill* compacted in accordance with 3.2.2.2(a)(iii) and extending past the perimeter of the building 1 m with a slope ratio not steeper than 2 horizontal to 1 vertical (see Figure 3.2.2.1).
- (c) Pad footings, strip footings and edge beams not connected to the slab, must be—
 - (i) founded in natural soil with an allowable bearing pressure of not less than 100 kPa; or
 - (ii) for Class A and S *sites* they may be founded on controlled sand fill in accordance with 3.2.2.2(a).

3.2.2.4 Slab edge support on sloping sites

Footings and slabs installed on the low side of sloping *sites* must be as follows:

- (a) Slab panels — in accordance with 3.2.2.3(a).
- (b) Edge beams—
 - (i) supported by *controlled fill* in accordance with 3.2.2.3(b) (see Figure 3.2.2.1, Option 1); or
 - (ii) supported by deepened edge beams or bulk piers designed in accordance with AS 3600 (see Figure 3.2.2.1, Option 2); or
 - (iii) deepened (as per AS 2870) to extend into the natural soil level with a bearing capacity in accordance with 3.2.2.3(b) (see Figure 3.2.2.1, Option 3); or
 - (iv) stepped in accordance with AS 2870.
- (c) Edge beams not connected to the slab, pad footings and strip footings — founded in accordance with 3.2.2.3(c).
- (d) Where an excavation (cut) of the natural ground is used it must be in accordance with Part 3.1.1.

Footings and Slabs

Figure 3.2.2.1

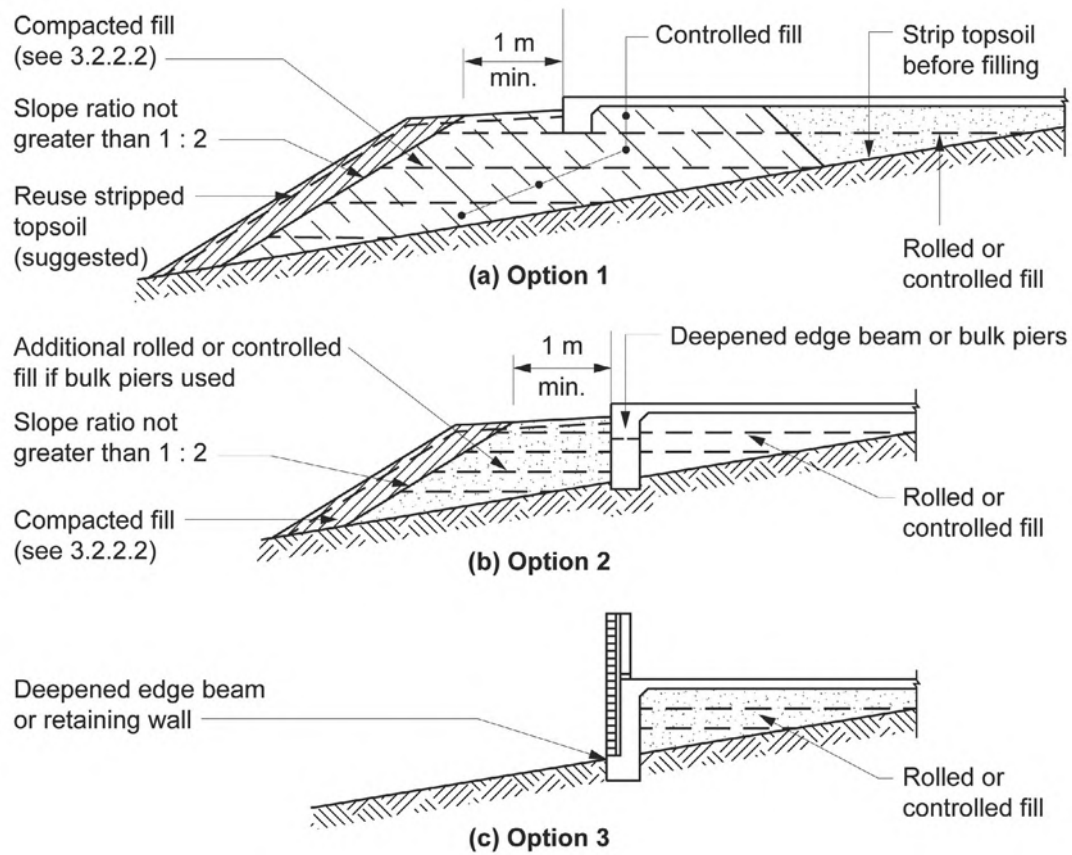
**Explanatory information:**

The *foundations* of a building are critical to its successful performance. As such, the soil must have the strength or bearing capacity to carry the building load with minimum movement.

The bearing capacity of a soil varies considerably and needs to be determined on a *site* by *site* basis. For this to occur, the appropriate people need to be consulted. These people may include a qualified engineer or experienced engineering geologist, or it may be determined by a person with appropriate local knowledge. The minimum bearing capacity (soil strength rating) may depend on the *site* conditions. The soil may be naturally undisturbed or be disturbed by building work or the like. Where soil is disturbed by building work and the like, the bearing capacity can be dramatically altered. This is typically the case for sloping *sites* where cut and fill procedures are used. In these situations the soil needs to be consolidated, generally via compaction, to achieve the *required* bearing capacity.

There are a number of alternatives for working on cut and filled sites. These are described in Figure 3.2.2.1.

Option 1 of Figure 3.2.2.1 refers to the *controlled fill* process which involves the compaction of fill in layers to achieve the bearing capacity described in 3.2.2.3. The depth of fill for each layer is specified to ensure effective compaction. Fill beyond these depths will need to be installed in accordance with the acceptable construction manuals set out in 3.2.0.

Option 2 and 3 of Figure 3.2.2.1 refer to edge beams that extend through the fill into undisturbed soil which provides the 3.2.2.3 *required* bearing capacity. In this situation the fill is essentially only taking the internal slab loads.

3.2.2.5 Stepped footings

Stepped strip footings must be constructed as follows—

- the base of the footing must be horizontal or have a slope of not more than 1:10; or
- be stepped in accordance with one of the methods shown in Figure 3.2.2.2.

Footings and Slabs

Figure 3.2.2.2 Stepped strip footings

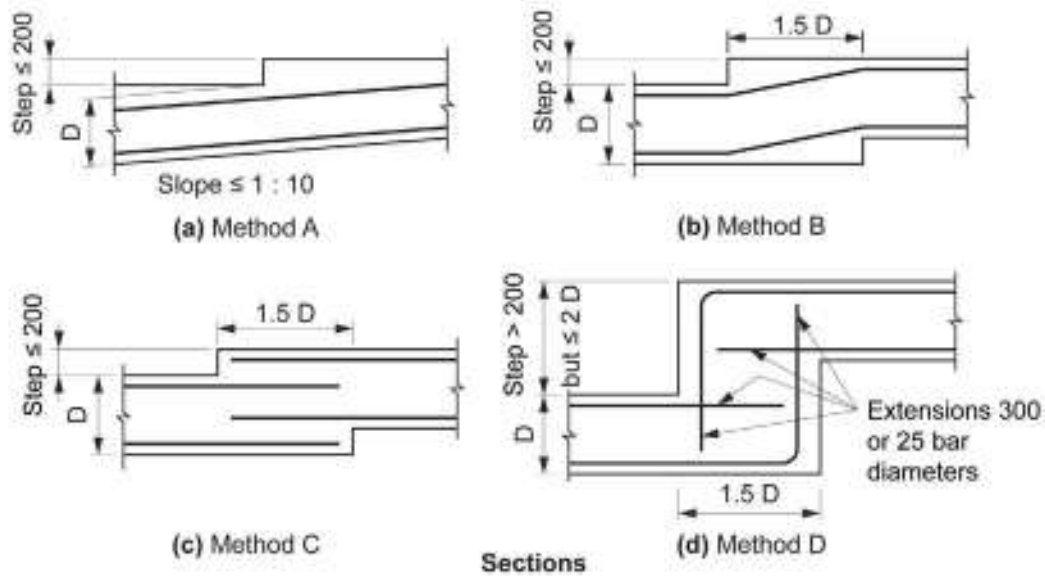

Note to Figure 3.2.2.2: All dimensions in millimetres.

3.2.2.6 Vapour barriers

A vapour barrier must be installed under slab-on-ground construction for all Class 1 buildings and for Class 10 buildings where the slab is continuous with the slab of a Class 1 building as follows—

(a) Materials

A vapour barrier must be—

- (i) 0.2 mm nominal thickness polyethylene film; and
- (ii) medium impact resistant, determined in accordance with criteria specified in clause 5.3.3.3 of AS 2870; and
- (iii) be branded continuously “AS 2870 Concrete underlay, 0.2 mm Medium impact resistance”.

(b) Installation

A vapour barrier must be installed as follows—

- (i) lap not less than 200 mm at all joints; and
- (ii) tape or seal with a close fitting sleeve around all service penetrations; and
- (iii) fully seal where punctured (unless for service penetrations) with additional polyethylene film and tape.

(c) The vapour barrier must be placed beneath the slab so that the bottom surface of the slab is entirely overlaid and extends under edge beams to finish at ground level in accordance with Figure 3.2.2.3.

State and Territory Variations

In New South Wales delete 3.2.2.6 and insert NSW 3.2.2.6 as follows:

NSW 3.2.2.6 Damp-proofing membrane

A damp-proofing membrane must be installed under slab-on-ground construction for all Class 1 buildings and for Class 10 buildings where the slab is continuous with the slab of a Class 1 building as follows—

(a) Materials

A damp-proofing membrane must be—

- (i) 0.2 mm nominal thickness polyethylene film; and
- (ii) high impact resistant, determined in accordance with criteria specified in clause 5.3.3.3 of AS 2870; and
- (iii) be branded continuously “AS 2870 Concrete underlay, 0.2 mm High impact resistance”.

Footings and Slabs

(b) Installation

A damp-proofing membrane must be installed as follows—

- (i) lap not less than 200 mm at all joints; and
 - (ii) tape or seal with a close fitting sleeve around all service penetrations; and
 - (iii) fully seal where punctured (unless for service penetrations) with additional polyethylene film and tape.
- (c) The damp-proofing membrane must be placed beneath the slab so that the bottom surface of the slab is entirely underlaid and extends under edge beams to finish at ground level in accordance with [Figure 3.2.2.3](#).

Note: A range of polyethylene films can be used, including black film and orange film, provided they satisfy the requirements for high impact resistance in accordance with the criteria specified in clause 5.3.3.3 of AS 2870.

In South Australia delete 3.2.2.6 and insert SA 3.2.2.6 as follows:

SA 3.2.2.6 Damp-proofing membrane

A continuous damp-proofing membrane must be installed under slab-on-ground construction for all Class 1 buildings and for Class 10 buildings where the slab is continuous with the slab of a Class 1 building as follows—

(a) Materials

A damp-proofing membrane must be—

- (i) 0.2 mm nominal thickness polyethylene film; and
- (ii) high impact resistant with resistance to puncturing and moisture penetration, determined in accordance with criteria specified in clause 5.3.3.3 of AS 2870; and
- (iii) be branded continuously “AS 2870 Concrete underlay, 0.2 mm High impact resistance” together with the manufacturer’s or distributor’s name, trade mark or code.

(b) Installation

A damp-proofing membrane must be installed as follows—

- (i) lap not less than 200 mm at all joints; and
 - (ii) tape or seal with a close fitting sleeve around all service penetrations; and
 - (iii) fully seal where punctured (unless for service penetrations) with additional polyethylene film and tape.
- (c) The damp-proofing membrane must be placed beneath the slab so that the bottom surface of the slab is entirely underlaid and extends under edge beams to finish at ground level in accordance with [Figure 3.2.2.3](#).

3.2.2.7 Edge rebates

Edge rebates for slab-on-ground, stiffened raft or *waffle raft* with masonry *cavity* or veneer construction must comply with the following:

- (a) The rebate must not be less than 20 mm, except as provided for in (d).
- (b) Exterior masonry must not overhang more than 15 mm past the edge of the slab.
- (c) The edge rebate must be flashed and drained in accordance with [Part 3.3.4](#) and where it cannot be flashed it must be filled with mortar.
- (d) Edge rebates are not *required* for *single leaf masonry*.

Explanatory information:

See [3.2.5.4](#) for minimum edge beam details.

Footings and Slabs

Figure 3.2.2.3 Acceptable vapour barrier and damp-proofing membrane location

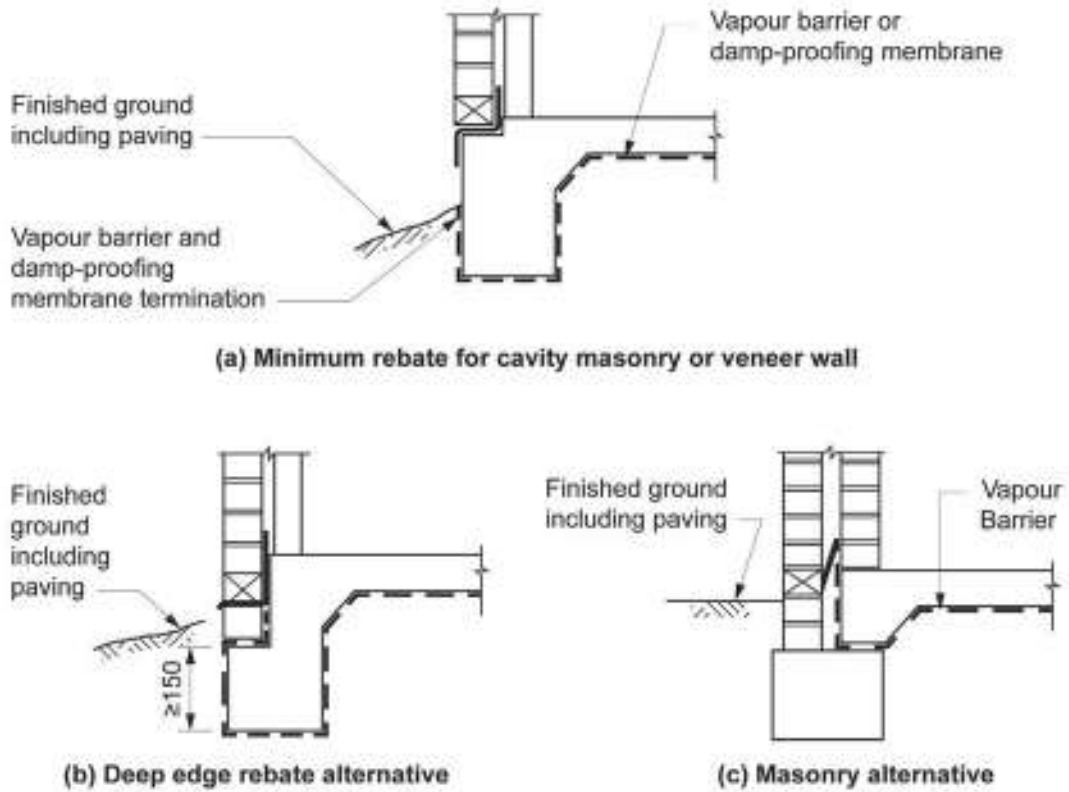

Note to Figure 3.2.2.3: All dimensions in millimetres.

Part 3.2.3 Concrete and reinforcing

3.2.3.1 Concrete

Concrete must comply with the following:

- (a) Concrete must be manufactured to comply with AS 3600; and—
 - (i) have a strength at 28 days of not less than 20 MPa (denoted as N20 grade); and
 - (ii) have a 20 mm maximum nominal aggregate size; and
 - (iii) have a nominal 100 mm slump.
- (b) Water must not be added to the mix to increase the slump to a value in excess of that specified.
- (c) Concrete must be placed, compacted and cured in accordance with good building practice.

State and Territory Variations

In South Australia after 3.2.3.1(c) insert SA 3.2.3.1(d), (e), (f) and (g) as follows:

- (d) Concrete in slabs must be adequately compacted, and slab surfaces, including edges, moist cured for 7 days.
- (e) After vertical surfaces are stripped of formwork, slab edges must be finished prior to curing.
- (f) Loading of concrete slabs with stacked materials or building plant must not occur for a minimum of 7 days after pouring although construction of wall frames and setting out brickwork may be undertaken during this period.
- (g) Concrete must not be poured if the air temperature on *site* exceeds 32°C unless written instructions from a *professional engineer* are followed.

Explanatory information:

1. Complete discharge of the concrete from the truck should be made within one and a half hours of initial mixing with water unless a suitable retarder has been specified.
2. Compacting concrete by vibration removes air pockets and works the concrete thoroughly around reinforcement, service penetrations etc. and into corners of formwork to increase durability and resistance to termite infestation and salt damp attack. Care should be taken not to over-vibrate. The finishing and curing of slab edges provides an improved edge finish which is resistant to edge dampness.
3. Care should be taken when using chemical curing methods, because some products may not be compatible with adhesives used to fix surface finishes to the slab.

3.2.3.2 Steel reinforcement

- (a) Materials used for reinforcing steel must comply with AS 2870 and be—
 - (i) welded wire reinforcing fabric; or
 - (ii) trench mesh; or
 - (iii) steel reinforcing bars.
- (b) Steel reinforcing bars may be substituted for trench mesh in accordance with [Table 3.2.3.2](#).

Explanatory information:

Reinforcement types referenced in this Part are described as follows:

1. Square mesh is designated in terms of the diameter of each bar and the spacing of consecutive bars. For example, SL62 consists of 6 mm bar at 200 mm spacings.
 2. Trench mesh is designated in terms of the number of longitudinal bars and the diameter of each bar. For example, 3-L11TM consists of 3 longitudinal bars each of which are 11 mm in diameter.
 3. Reinforcing bars are designated in terms of the number of bars and the diameter of each bar. For example, 6-N12 consists of 6 bars each of which are 12 mm in diameter.
- (c) Minimum laps for reinforcement as shown in [Table 3.2.3.1](#) and [Figure 3.2.3.1](#) must be provided where reinforcing is used.

Footings and Slabs

Table 3.2.3.1 Minimum lap for reinforcement

Reinforcement	Minimum splice	Minimum Lap at "T" intersections	Minimum Lap at "L" intersections
Steel reinforcing bars	500 mm	Full width across the junction	One outer bar must be bent and continue 500 mm (min) around corner
Trench mesh	500 mm	Full width across the junction	Full width across the junction
Square and Rectangular Mesh	The two outermost transverse wires of one sheet must overlap the two outermost transverse wires of the other	Not applicable	Not applicable

Figure 3.2.3.1

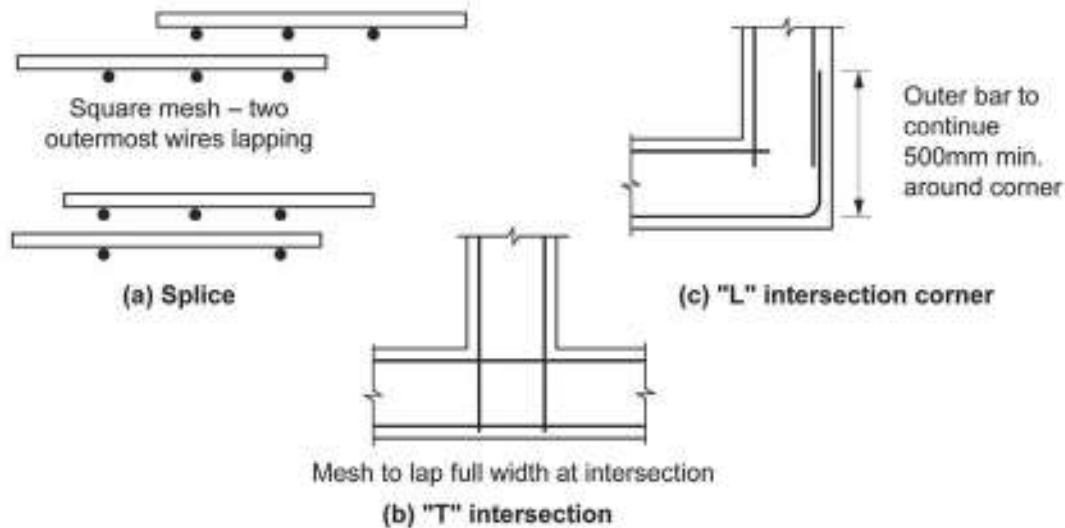

Table 3.2.3.2 Alternative mesh/reinforcing bar sizes

Trench mesh (TM)	Area — mm ²	Reinforcing bar alternative	Trench mesh alternative
2-L8TM	91	2-N10 or 1-N12	Not applicable
3-L8TM	136	2-N10 or 2-N12	Not applicable
4-L8TM	182	2-N12	2-L11TM
5-L8TM	227	2-N12	3-L11TM
2-L11TM	180	1-N16 or 2-N12	2x2-L8TM
3-L11TM	270	3-N12	2x3-L8TM
4-L11TM	360	2-N16	2x4-L8TM
2-L12TM	222	2-N12	3-L11TM
3-L12TM	333	3-N12	4-L11TM
4-L12TM	444	4-N12	5-L11TM

Notes to Table 3.2.3.2:

- Where necessary 2 layers of mesh may be used.
 - L11TM and L12TM may be replaced by RL1118 and RL1218 mesh respectively.
 - L11TM may be replaced by two layers of L8TM.
- (d) Footings and slabs-on-ground must have concrete cover between the outermost edge of the reinforcement (including ligatures, tie wire etc.) and the surface of the concrete of not less than the following:

Footings and Slabs

- (i) 40 mm to unprotected ground.
 - (ii) 30 mm to a membrane in contact with the ground.
 - (iii) 20 mm to an internal surface.
 - (iv) 40 mm to external exposure.
- (e) Reinforcement must be cleaned of loose rust, mud, paints and oils immediately prior to the concrete pour.

Explanatory information:

In order to obtain a good bond between concrete and reinforcement, the reinforcement should be free of contamination by mud, paint, oils, etc. It is not necessary for the reinforcement to be completely free of rust. Some rusting is beneficial in promoting a good bond as it roughens the surface of the steel. Loose rust, however, must be removed from the reinforcement.

- (f) Reinforcement must be placed as follows:
- (i) All reinforcement must be firmly fixed in place to prevent it moving during concreting operations.
 - (ii) Reinforcement must be supported off the ground or the forms by bar chairs made from wire, concrete or plastic.
 - (iii) When using wire chairs the minimum concrete cover (see [3.2.3.2\(d\)](#)) to the uncoated portion of the chair must be obtained.
 - (iv) Wire chairs on soft ground or plastic membrane must be placed on flat bases.
 - (v) Bar chairs must be spaced at not more than 800 mm centres for steel fabric.

Explanatory information:

Reinforcement is designed to be in a particular place so as to add strength or to control cracking of the concrete. A displacement from its intended location could make a significant difference to the life or serviceability of the structure.

Supports for fabric reinforcement are provided to prevent the fabric distorting when workers walk on top of it to place the concrete and maintain the correct concrete cover to the fabric.

Part 3.2.4 Site classification

3.2.4.1 Site classification

The *foundation* where the footing is to be located must be classified in accordance with AS 2870.

Explanatory information:

Table 3.2.4.1 provides a general description of *foundation* soil types that will assist in the classification of the *site*. More detailed information, including differentiation between classifications, can be found in AS 2870 or alternatively contact the *appropriate authority*.

Due to the limitations of this Part, if a *site* is classified as E or P then reference must be made to AS 2870 for design and construction information.

Table 3.2.4.1 General definition of site classes

Class	Foundation
A	Most sand and rock <i>sites</i> with little or no ground movement from moisture changes
S	Slightly reactive clay <i>sites</i> with only slight ground movement from moisture changes
M	Moderately reactive clay or silt <i>sites</i> which can experience moderate ground movement from moisture changes
H	Highly reactive clay <i>sites</i> which can experience high ground movement from moisture changes
E	Extremely reactive clay <i>sites</i> which can experience extreme ground movement from moisture changes
A to P	Filled <i>sites</i> — see AS 2870
P	<i>Sites</i> which include soft soils, such as soft clay or silt or loose sands; landslip; mine subsidence; collapsing soils; soils subject to erosion; reactive <i>sites</i> subject to abnormal moisture conditions or <i>sites</i> which cannot be classified otherwise

Note to Table 3.2.4.1: For classes M, H and E further division based on the depth of the expected movement is *required*. For deep-seated movements, characteristic of dry climates and corresponding to a design depth of suction change H_s , equal to or greater than 3 m, the classification shall be M-D, H-D or E-D as appropriate. For example, H-D represents a highly reactive *site* with deep moisture changes, and H represents a highly reactive *site* with shallow moisture changes.

Part 3.2.5 Footing and slab construction

Explanatory information:

The footings included in this Part reflect the requirements of AS 2870 and apply to the most common types of soil conditions. If the soil conditions on *site* are not covered by this Part then additional guidance can be obtained from AS 2870 or the *appropriate authority*.

These provisions are not meant to prohibit the use of alternative traditional footing methods found through experience to be suitable for local soil conditions (especially those used in stable soils). Such footings may be appropriate, provided they meet the relevant *Performance Requirements* listed in [Section 2](#).

The diagrams in this Part reflect acceptable footing designs only. They do not provide details for termite management systems such as the correct placement of ant capping and slab edge exposure.

For details on termite management systems, see [Part 3.1.3](#).

3.2.5.1 Footing and slab construction

- (a) Footing and slab construction, including size and placement of reinforcement, must comply with the relevant provisions of this Part and the following details:
- (i) Footings for stumps — the appropriate details in [3.2.5.6](#) and [Table 3.2.5.2](#).
 - (ii) Stiffened raft Class A, S, M, M-D, H and H-D *sites* — the appropriate details in [Figure 3.2.5.3a](#) and [Figure 3.2.5.3b](#).
 - (iii) Strip footing systems in Class A, S, M, M-D and H *sites* — the appropriate details in [Figure 3.2.5.4a](#) and [Figure 3.2.5.4b](#).
 - (iv) Footing slabs for Class A *sites* — the appropriate details in [Figure 3.2.5.5](#).
- (b) Footings for *single leaf masonry*, *mixed construction* and earth wall masonry must comply with the equivalent footing construction set out in [Table 3.2.5.1](#).

3.2.5.2 Footings and slabs to extensions to existing buildings

- (a) Footings to extensions to Class 1 or 10 buildings may be of similar proportions and details to those used with an existing same Class of building on the same allotment provided—
- (i) masonry and masonry veneer walls are articulated at the junction with the existing building; and
 - (ii) the performance of the existing building has been satisfactory, i.e. there has been no significant cracking or movement (see Section 2 of AS 2870 for acceptable footing performance); and
 - (iii) there are no unusual moisture conditions on the *site*.
- (b) Class 10 buildings of *clad framed* construction may use footing systems appropriate for one class of reactivity less severe than for a house (e.g. site classification M can be reduced to S).

Table 3.2.5.1 Equivalent footing construction

Actual construction		Equivalent footing construction
External walls	Internal walls	(see Figure 3.2.5.2 to Figure 3.2.5.5)
<i>Single leaf masonry</i>	<i>Single leaf masonry</i>	<i>Single leaf masonry</i>
Reinforced <i>single leaf masonry</i>	<i>Articulated masonry</i> on Class A and S <i>sites</i> ; or framed	<i>Articulated masonry</i> veneer
Reinforced <i>single leaf masonry</i>	<i>Articulated masonry</i> or reinforced <i>single leaf masonry</i>	Masonry veneer
Articulated <i>single leaf masonry</i>	<i>Articulated masonry</i>	Articulated full masonry
<i>Mixed construction</i>	<i>Mixed construction</i>	<i>Mixed construction</i>
Full masonry	Framed	Articulated full masonry
Articulated full masonry	Framed	Masonry veneer
Earth wall masonry	Earth wall masonry	Earth wall masonry
Infill panels of earth masonry	Framed earth masonry	<i>Articulated masonry</i> veneer

Footings and Slabs

Actual construction		Equivalent footing construction
External walls	Internal walls	(see Figure 3.2.5.2 to Figure 3.2.5.5)
<i>Loadbearing</i> earth masonry	<i>loadbearing</i> earth masonry	Articulated full masonry

3.2.5.3 Shrinkage control

- (a) Where brittle floor coverings, such as ceramic tiles, are to be used over an area greater than 16 m², one of the following additional measures must be taken to control the effect of shrinkage cracking—
- (i) the amount of shrinkage reinforcement (steel reinforcement mesh in the slab panel) must be—
 - (A) increased to SL92 or equivalent throughout the affected slab area; or
 - (B) doubled with an additional sheet of slab mesh throughout the affected slab area; or
 - (ii) the bedding system for brittle coverings must be selected on the basis of the expected slab movement and the characteristics of the floor covering (including the use of expansion joints etc.); or
 - (iii) the placement of floor covering must be delayed for not less than 3 months after the concrete has been poured.
- (b) At re-entrant or internal corners, two strips, minimum 2 m in length, of 3–L8TM or one strip of 3–L11TM (or 3–N12 bars) must be placed diagonally across the corner in accordance with [Figure 3.2.5.1](#).

Figure 3.2.5.1 Reinforcing at re-entrant corners

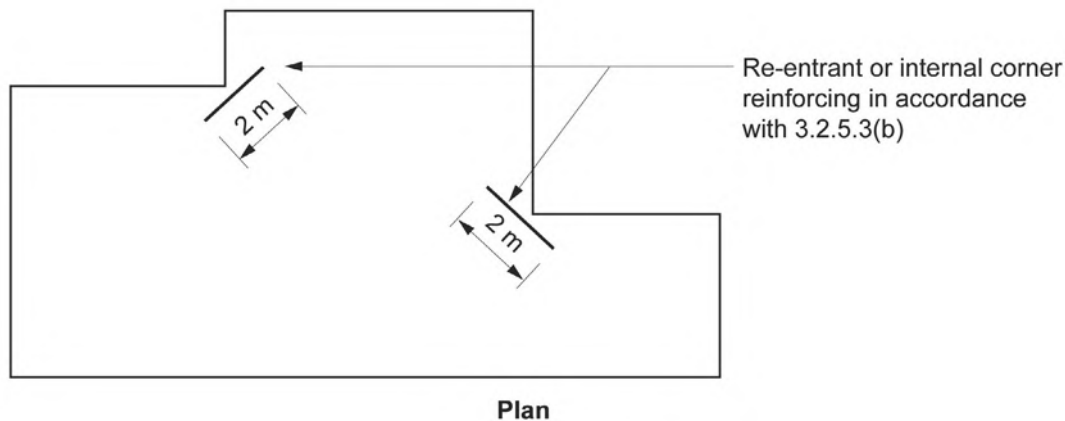

3.2.5.4 Minimum edge beam dimensions

Except for *waffle raft* slabs, where the edge rebate is more than 150 mm in depth, the width of the edge beam at the base of the rebate must not be less than 200 mm, except that if R10 or N10 ties at 900 mm spacing (or equivalent) are provided to resist vertical forces, the width of the edge beam at the base of the rebate can be reduced to 150 mm.

3.2.5.5 Footings for fireplaces on Class A and S sites

- (a) Fireplaces must be supported on a pad footing—
- (i) 150 mm thick for single storey (one trafficable floor and a wall height not more than 4.2 m) construction; and
 - (ii) 200 mm thick for 2 storey (two trafficable floors and a wall height not more than 8 m) construction; and
 - (iii) reinforced top and bottom with SL72 mesh; and
 - (iv) extending 300 mm past the edges of the masonry except for any edge flush with the outer wall.
- (b) The pad footing may form an integral part of the slab.

3.2.5.6 Stump footing details

- (a) Footings for stumps must comply with—
- (i) the provisions of [Table 3.2.5.2](#) for Class A and Class S *sites*; or

Footings and Slabs

- (ii) the appropriate acceptable construction manual listed in—
 - (A) [Part 3.4.3](#); or
 - (B) [3.2.0](#).
- (b) Concrete stumps must—
 - (i) be designed in accordance with—
 - (A) AS 3600; or
 - (B) [Table 3.2.5.2](#); and
 - (ii) use a minimum 20 MPa concrete as defined in AS 3600.
- (c) Steel stumps must be—
 - (i) designed in accordance with—
 - (A) AS 4100; or
 - (B) [Table 3.2.5.2](#); and
 - (ii) fully enclosed and sealed with a welded top plate; and
 - (iii) encased in concrete sloping away from the stump and finishing not less than 100 mm above *finished ground level*; and
 - (iv) corrosion protected in accordance with [Part 3.4.4](#).
- (d) Timber stumps must be designed in accordance with—
 - (i) AS 1684.2, AS 1684.3 or AS 1684.4; or
 - (ii) [Table 3.2.5.2](#).
- (e) Stumps must be braced—
 - (i) by a full perimeter masonry base; or
 - (ii) for concrete stumps — in accordance with AS 3600; or
 - (iii) for steel stumps — in accordance with AS 4100; or
 - (iv) for timber stumps — in accordance with AS 1684.2, AS 1684.3 or AS 1684.4.
- (f) Stumps must be embedded into the foundation material not less than 30% of their height above ground level or 450 mm, whichever is the greater.

Table 3.2.5.2 Stump footing — in areas with a design wind speed of not more than N2

Stump footing material	Length of stump (including embedded length)	Length of stump (including embedded length)	Length of stump (including embedded length)
	1400 mm or less	1401–1800 mm	1801–3000 mm
Concrete	Minimum size: 100 mm × 100 mm or 110 mm diameter Reinforcement: Minimum number of 5 mm hard drawn wires: 1	Minimum size: 100 mm × 100 mm or 110 mm diameter Reinforcement: Minimum number of 5 mm hard drawn wires: 2	Minimum size: 125 mm × 125 mm or 140 mm diameter Reinforcement: Minimum number of 5 mm hard drawn wires: 2
Steel	Minimum size: 75 mm × 75 mm × 2.0 mm SHS	Minimum size: 75 mm × 75 mm × 2.0 mm SHS	Minimum size: 75 mm × 75 mm × 2.0 mm SHS
Timber	Minimum size: 100 mm × 100 mm or 110 mm diameter	Minimum size: 100 mm × 100 mm or 110 mm diameter	Minimum size: 100 mm × 100 mm or 110 mm diameter

Note to Table 3.2.5.2: SHS = square hollow section.

Footings and Slabs

Figure 3.2.5.2 Pad footings for clad frame, Class A and S sites

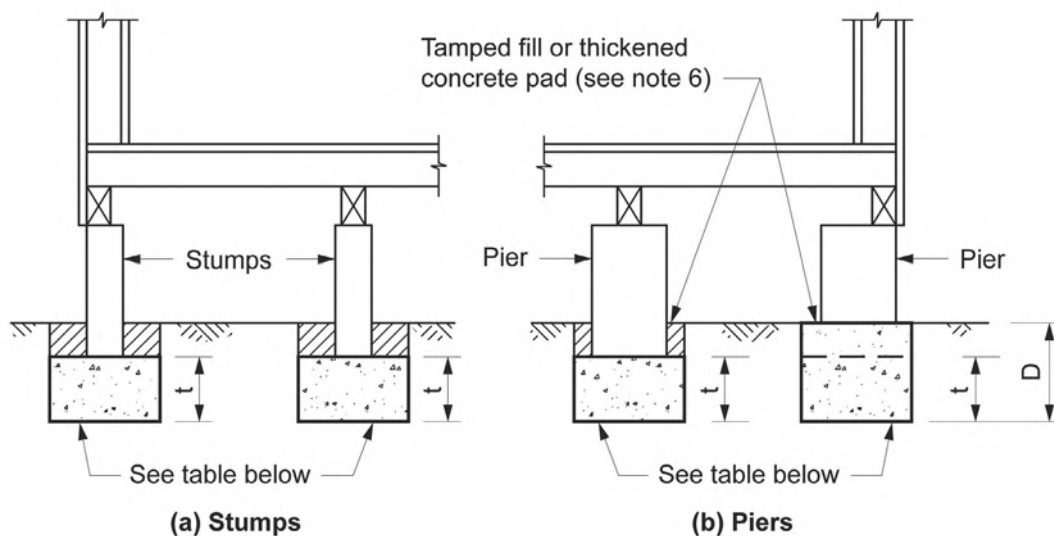

Table 3.2.5.3 Minimum dimensions of circular and square pad footings for clad frame, Class A and S sites

Effective supported areas (m ²)	Width of square pad (mm)	Width of circular pad (mm)	Thickness (t) (mm)	Depth (mm)
10	400	500	200	400
20	500	600	200	400
30	600	750	250	400

Notes to Table 3.2.5.3:

- The effective area supported by a pad footing is the sum of—
 - the supported floor area; and
 - the supported roof area (if applicable); and
 - half the supported wall area in elevation (if applicable).
- The width or diameter can be reduced to one half the above footings on rock.
- The pad footings must be constructed in concrete except that masonry footings can be used under masonry piers.
- Pad footing sizes must also apply to footings supporting roof and floor loads only.
- The *foundation* must provide an allowable bearing pressure of not less than 100 kPa.
- The excavation must be backfilled with manually rodded tamped soil, or the footing thickness shall be increased by 50 mm.
- Where stump pad footings provide resistance to horizontal or uplift forces, the minimum size of the footing must comply with AS 2870.
- Braced stumps must comply with 3.2.5.6(e).

Footings and Slabs

Figure 3.2.5.3a Footing slab and stiffened raft slab details for Class A and S sites

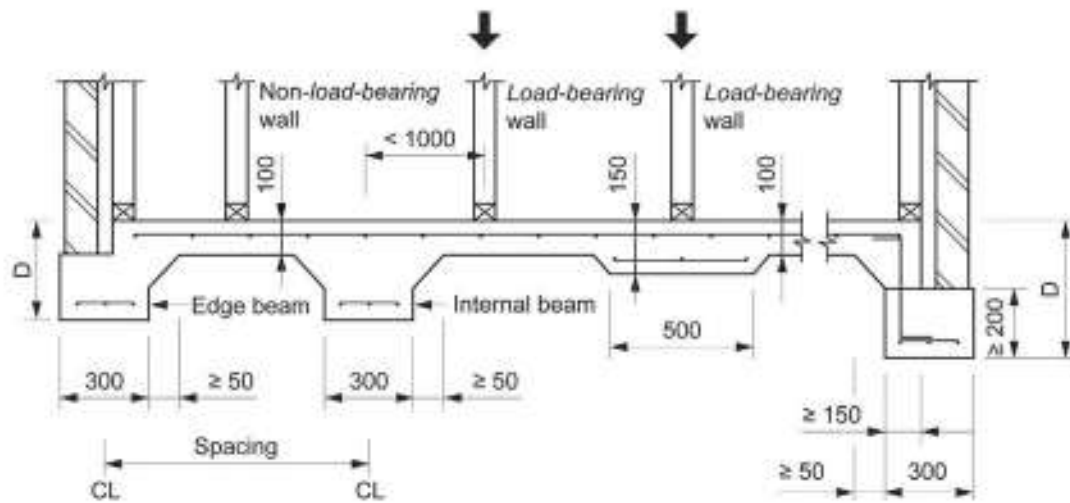

Table 3.2.5.4a Reinforcement for stiffened raft footings for Class A sites

Type of construction	Depth (D) (mm)	Bottom reinf.	Max. spacing c/l to c/l	Slab fabric where slab length <18 m	Slab fabric where slab length <25 m	Slab fabric where slab length <30 m
<i>Clad frame</i>	300	3-L8TM	N/A	SL72	SL82	SL92
<i>Articulated masonry veneer</i>	300	3-L8TM	N/A	SL72	SL82	SL92
Masonry veneer	300	3-L8TM	N/A	SL72	SL82	SL92
Articulated full masonry	400	3-L8TM	N/A	SL72	SL82	SL92
Full masonry	400	3-L8TM	N/A	SL72	SL82	SL92

Table 3.2.5.4b Reinforcement for stiffened raft footings for Class S sites

Type of construction	Depth (D) (mm)	Bottom reinf.	Max. spacing c/l to c/l	Slab fabric where slab length <18 m	Slab fabric where slab length <25 m	Slab fabric where slab length <30 m
<i>Clad frame</i>	300	3-L8TM	N/A	SL72	SL82	SL92
<i>Articulated masonry veneer</i>	300	3-L8TM	N/A	SL72	SL82	SL92
Masonry veneer	300	3-L11TM	N/A	SL72	SL82	SL92
Articulated full masonry	400	3-L11TM	N/A	SL72	SL82	SL92
Full masonry	450	3-L11TM	5.0 (m) ^{Note 2}	SL82	SL82	SL92

Notes to Tables 3.2.5.4a to 3.2.5.4b:

- Internal and external edge beams must be arranged to form an integral structural grid (see clauses 5.3.8 and 5.3.9 of AS 2870).
- A 10% increase in spacings is permitted where the spacing in the other direction is 20% less than that specified.
- Where external beams are wider than 300 mm, an extra bottom bar or equivalent of the same bar size is *required* for each 100 mm additional width.
- Where a reinforced *single leaf masonry* wall is constructed directly above and structurally connected to a concrete

Footings and Slabs

edge beam, the beam may be reduced to 300 mm wide by 300 mm deep and reinforced with 3–L8TM reinforcement.

5. Alternative reinforcement sizes must comply with AS 2870.
6. Internal beam details and spacings must comply with [Figure 3.2.5.3a](#) or [Figure 3.2.5.3b](#). At a re-entrant corner where an external beam continues as an internal beam, the internal beam details must be continued for a length of 1 m into the external beam.

Figure 3.2.5.3b Footing slab and stiffened raft slab details for Class M, M-D, H and H-D sites

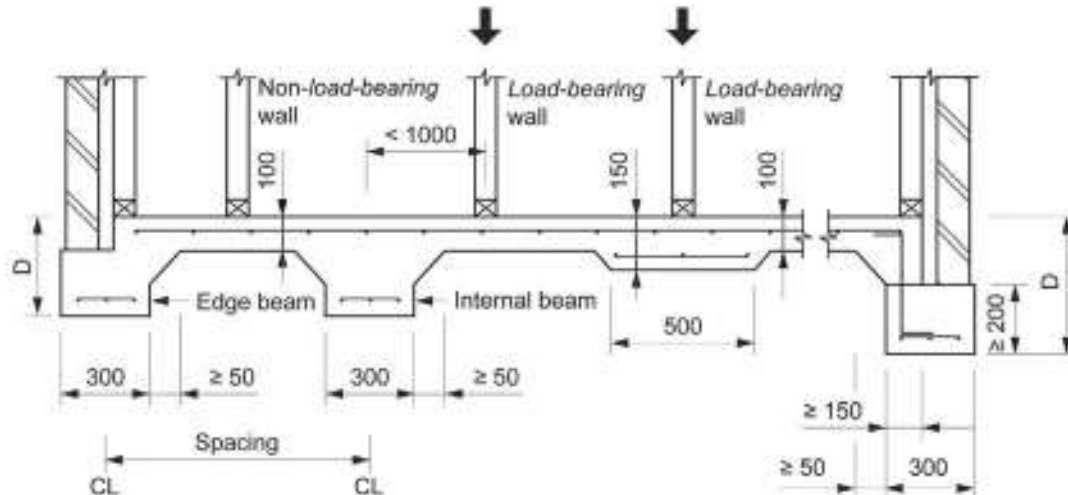

Table 3.2.5.5a Reinforcement for stiffened raft footings for Class M sites

Type of construction	Depth (D) (mm)	Bottom reinf.	Max. spacing c/l to c/l (m)	Slab mesh where slab length <18 m	Slab mesh where slab length <25 m	Slab mesh where slab length <30 m
<i>Clad frame</i>	300	3-L11TM	6.0 ^{Note 2}	SL72	SL82	SL92
<i>Articulated masonry veneer</i>	400	3-L11TM	6.0 ^{Note 2}	SL72	SL82	SL92
Masonry veneer	400	3-L11TM	5.0 ^{Note 2}	SL72	SL82	SL92
Articulated full masonry	500	3-L12TM	4.0	SL82	SL82	SL92
Full masonry	800	3-N16	4.0	SL92	SL92	SL92

Table 3.2.5.5b Reinforcement for stiffened raft footings for Class M-D sites

Type of construction	Depth (D) (mm)	Bottom reinf.	Max. spacing c/l to c/l (m)	Slab mesh where slab length <18 m	Slab mesh where slab length <25 m	Slab mesh where slab length <30 m
<i>Clad frame</i>	400	3-L11TM	5.0 ^{Note 2}	SL72	SL82	SL92
<i>Articulated masonry veneer</i>	400	3-L11TM	4.0	SL72	SL82	SL92
Masonry veneer	500	3-L12TM	4.0	SL82	SL82	SL92
Articulated full masonry	625	3-L12TM	4.0	SL92	SL92	SL92
Full masonry	N/A	N/A	N/A	N/A	N/A	N/A

Footings and Slabs

Table 3.2.5.5c Reinforcement for stiffened raft footings for Class H sites

Type of construction	Depth (D) (mm)	Bottom reinf.	Max. spacing c/l to c/l (m)	Slab mesh where slab length <18 m	Slab mesh where slab length <25 m	Slab mesh where slab length <30 m
<i>Clad frame</i>	400	3-L11TM	5.0 ^{Note 2}	SL72	SL82	SL92
Articulated full masonry	500	3-L12TM	4.0	SL82	SL82	SL92
Masonry veneer	700	3-N16	4.0	SL92	SL92	SL92
Articulated full masonry	1000	4-N16	4.0	SL102	SL102	SL102
Full masonry	N/A	N/A	N/A	N/A	N/A	N/A

Table 3.2.5.5d Reinforcement for stiffened raft footings for Class H-D sites

Type of construction	Depth (D) (mm)	Bottom reinf.	Max. spacing c/l to c/l (m)	Slab mesh where slab length <18 m	Slab mesh where slab length <25 m	Slab mesh where slab length <30 m
<i>Clad frame</i>	500	3-L11TM	4.0	SL82	SL82	SL92
<i>Articulated masonry veneer</i>	600	3-L12TM	4.0	SL92	SL92	SL92
Masonry veneer	N/A	N/A	N/A	N/A	N/A	N/A
Articulated full masonry	1200	4-N16	4.0	SL102	SL102	SL102
Full masonry	N/A	N/A	N/A	N/A	N/A	N/A

Notes to Table 3.2.5.5a to 3.2.5.5d:

- Internal and external edge beams must be arranged to form an integral structural grid (see clauses 5.3.8 and 5.3.9 of AS 2870).
- A 10% increase in spacings is permitted where the spacing in the other direction is 20% less than that specified.
- Where external beams are wider than 300 mm, an extra bottom bar or equivalent of the same bar size is *required* for each 100 mm additional width.
- Where a reinforced *single leaf masonry* wall is constructed directly above and structurally connected to a concrete edge beam, the beam may be reduced to 300 mm wide by 300 mm deep and reinforced with 3-L8TM reinforcement.
- Alternative reinforcement sizes must comply with AS 2870.
- Internal beam details and spacings must comply with [Figure 3.2.5.3b](#). At a re-entrant corner where an external beam continues as an internal beam, the internal beam details must be continued for a length of 1 m into the external beam.

Footings and Slabs

Figure 3.2.5.4a Strip footing systems for Class A and S sites

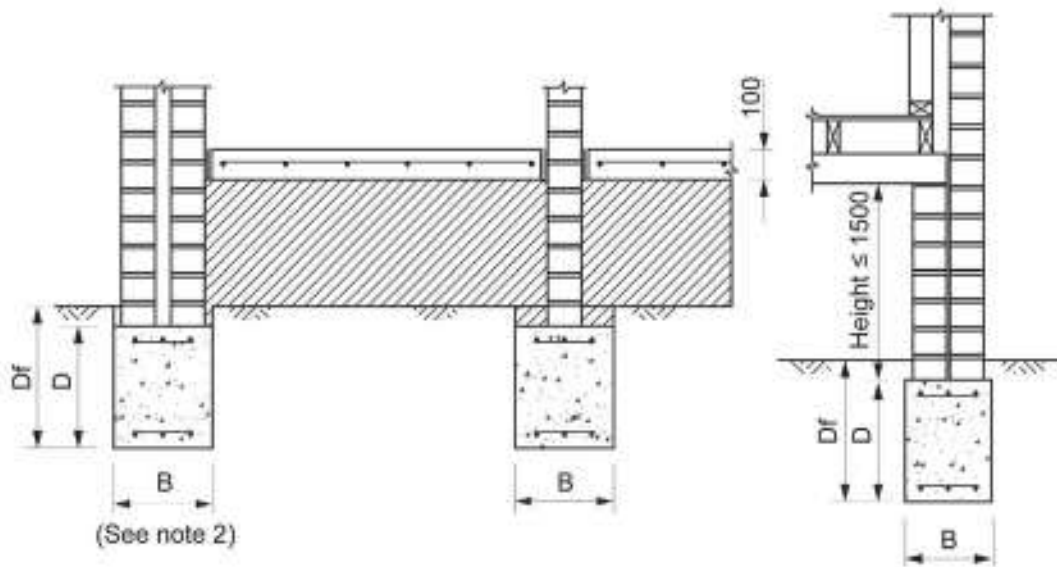

Table 3.2.5.6a Dimensions and reinforcement for strip footing systems for Class A sites

Type of construction	D (mm)	B (mm)	Reinforcement (top and bottom)
<i>Clad frame</i>	300	300	3-L8TM
<i>Articulated masonry</i> veneer	300	300	3-L8TM
Masonry veneer	300	300	3-L8TM
Articulated full masonry	300	400	4-L8TM
Full masonry	300	400	4-L8TM

Notes to Table 3.2.5.6a:

- All masonry walls must be supported on strip footings.
- Internal strip footings must be of the same proportions as the external footings and run from external footing to external footing. "Side slip joints" consisting of a double layer of polyethylene must be provided at the sides of the footing only.
- Infill floors may be concrete slabs, brick paving, stone flags or compacted and stabilised earth. For concrete slab infill panels, mesh may be *required* to control shrinkage in slab panels and around openings or restrained regions. Concrete infill slabs must use a minimum of SL62 mesh to control shrinkage (see also 3.2.5.3).
- Where footings are wider than the specified width, an extra bottom bar or equivalent of the same bar size is *required* for each 100 mm additional width. If strip footings deeper than those *required* are used, the reinforcement must be increased to match that specified for the deepened proportions.
- The measurement of D_f is greater or equal to D plus 75 mm.
- Alternative reinforcing sizes must comply with AS 2870.

Table 3.2.5.6b Dimensions and reinforcement for strip footing systems for Class S sites

Type of construction	D (mm)	B (mm)	Reinforcement (top and bottom)
<i>Clad frame</i>	400	300	3-L8TM
<i>Articulated masonry</i> veneer	400	300	3-L8TM
Masonry veneer	400	300	3-L8TM
Articulated full masonry	400	400	4-L11TM
Full masonry	500	400	4-L11TM

Footings and Slabs

Notes Table 3.2.5.6b:

- All masonry walls must be supported on strip footings.
- Internal strip footings must be of the same proportions as the external footings and run from external footing to external footing. "Side slip joints" consisting of a double layer of polyethylene must be provided at the sides of the footing only.
- Infill floors may be concrete slabs, brick paving, stone flags or compacted and stabilised earth. For concrete slab infill panels, mesh may be *required* to control shrinkage in slab panels and around openings or restrained regions. Concrete infill slabs must use a minimum of SL62 mesh to control shrinkage (see also 3.2.5.3).
- Where footings are wider than the specified width, an extra bottom bar or equivalent of the same bar size is *required* for each 100 mm additional width. If strip footings deeper than those *required* are used, the reinforcement must be increased to match that specified for the deepened proportions.
- The measurement of D_f is greater or equal to D plus 75 mm.
- Alternative reinforcing sizes must comply with AS 2870.

Figure 3.2.5.4b Strip footing system for Class M, M-D and H sites

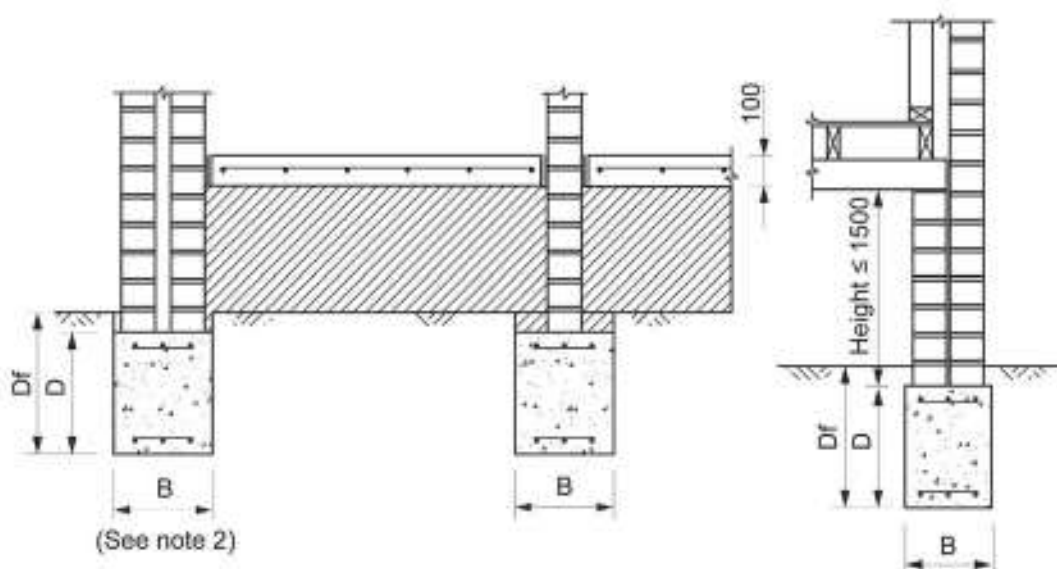

Table 3.2.5.7a Dimensions and reinforcement for strip footing systems for Class M sites

Site Class	Type of construction	D (mm)	B (mm)	Reinforcement (top and bottom)
Class M	<i>Clad frame</i>	400	300	3-L11TM
Class M	<i>Articulated masonry veneer</i>	450	300	3-L11TM
Class M	Masonry veneer	500	300	3-L12TM
Class M	Articulated full masonry	600	400	4-L12TM
Class M	Full masonry	900 <small>Note 2</small>	400	4-L12TM

Notes to Table 3.2.5.7a:

- All masonry walls must be supported on strip footings.
- For beams 700 mm or deeper, as specified in the table above, internal footings must be provided at no more than 6 m centres and at re-entrant corners to continue footings to the opposite external footing. Internal strip footings must be of the same proportions as the external footings and run from external footing to external footing. "Side slip joints" consisting of a double layer of polyethylene must be provided at the sides of the footing only.
- Infill floors must only be used for Class A and S sites.

Footings and Slabs

4. Where footings are wider than the specified width, an extra bottom bar or equivalent of the same bar size is *required* for each 100 mm additional width. If strip footings deeper than those *required* are used, the reinforcement must be increased to match that specified for the deepened proportions.
5. The measurement of D_f is greater or equal to D plus 75 mm.
6. Alternative reinforcing sizes must comply with AS 2870.
7. For Class M articulated full masonry and full masonry, internal strip footings must be of the same proportions as the external footing and run from external footing to external footing.

Table 3.2.5.7b Dimensions and reinforcement for strip footing systems for Class M-D sites

Site Class	Type of construction	D (mm)	B (mm)	Reinforcement (top and bottom)
Class M-D	<i>Clad frame</i>	500	300	3–L11TM
Class M-D	<i>Articulated masonry veneer</i>	550	300	3–L12TM
Class M-D	Masonry veneer	700 ^{Note 2}	300	3–N16
Class M-D	Articulated full masonry	1100 ^{Note 2}	400	4–N16

Notes to Table 3.2.5.7b:

1. All masonry walls must be supported on strip footings.
2. For beams 700 mm or deeper, as specified in the table above, internal footings must be provided at no more than 6 m centres and at re-entrant corners to continue footings to the opposite external footing. Internal strip footings must be of the same proportions as the external footings and run from external footing to external footing. “Side slip joints” consisting of a double layer of polyethylene must be provided at the sides of the footing only.
3. Infill floors must only be used for Class A and S sites.
4. Where footings are wider than the specified width, an extra bottom bar or equivalent of the same bar size is *required* for each 100 mm additional width. If strip footings deeper than those *required* are used, the reinforcement must be increased to match that specified for the deepened proportions.
5. The measurement of D_f is greater or equal to D plus 75 mm.
6. Alternative reinforcing sizes must comply with AS 2870.
7. For site Classes M-D and H, a provision must be made by methods such as an adequate crawl space to allow for future re-levelling due to drying effects.

Table 3.2.5.7c Dimensions and reinforcement for strip footing systems for Class H sites

Type of construction	D (mm)	B (mm)	Reinforcement (top and bottom)
<i>Clad frame</i>	500	300	3–L11TM
<i>Articulated masonry veneer</i>	600	300	3–L12TM
Masonry veneer	850 ^{Note 2}	300	3–N16
Articulated full masonry	1100 ^{Note 2}	400	4–N16

Notes to Table 3.2.5.7c:

1. All masonry walls must be supported on strip footings.
2. For beams 700 mm or deeper, as specified in the table above, internal footings must be provided at no more than 6 m centres and at re-entrant corners to continue footings to the opposite external footing. Internal strip footings must be of the same proportions as the external footings and run from external footing to external footing. “Side slip joints” consisting of a double layer of polyethylene must be provided at the sides of the footing only.
3. Infill floors must only be used for Class A and S sites.
4. Where footings are wider than the specified width, an extra bottom bar or equivalent of the same bar size is *required* for each 100 mm additional width. If strip footings deeper than those *required* are used, the reinforcement must be increased to match that specified for the deepened proportions.
5. The measurement of D_f is greater or equal to D plus 75 mm.

Footings and Slabs

6. Alternative reinforcing sizes must comply with AS 2870.
7. For site Classes M-D and H, a provision must be made by methods such as an adequate crawl space to allow for future re-levelling due to drying effects.

Figure 3.2.5.5 Footing slabs for Class A sites suitable for:

- (a) **Clad frame.**
- (b) **Articulated masonry veneer.**
- (c) **Masonry veneer.**
- (d) **Articulated full masonry.**
- (e) **Full masonry.**

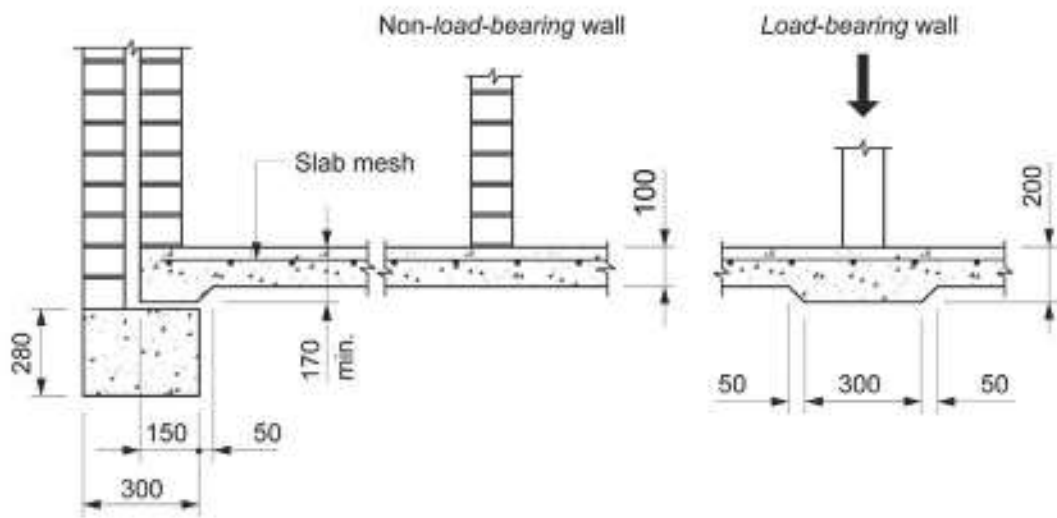

Notes to Figure 3.2.5.5:

1. Use SL63 when slab length is less than 12 m.
2. Use SL62 when slab length is less than 18 m.
3. Use SL72 when slab length is less than 25 m.
4. Use SL82 when slab length is less than 30 m.
5. In parts of Western Australia (around Perth) and other locations where the *site* consists of extremely stable sands, and where specified by a *professional engineer*, the slab thickness may be reduced to 85 mm and reinforced as follows:
 - a. Use SL53 when slab length is less than or equal to 12 m.
 - b. Use SL63 when slab length is less than or equal to 18 m.
 - c. Use SL62 when slab length is less than or equal to 25 m.
6. Dune sands may require compaction.

Masonry

- Part 3.3.1** **Unreinforced masonry**
- Part 3.3.2** **Reinforced masonry**
- Part 3.3.3** **Masonry accessories**
- Part 3.3.4** **Weatherproofing of masonry**
- Part 3.3.5** **Masonry veneer**
- Part 3.3.6** **Isolated masonry piers**

Part 3.3 Masonry

Part 3.3.1 Unreinforced masonry

Acceptable Construction Manuals

3.3.1.0

Part 3.3.2 Reinforced masonry

Acceptable Construction Manuals

3.3.2.0

Part 3.3.3 Masonry accessories

Acceptable Construction Manuals

3.3.3.0

Part 3.3.4 Weatherproofing of masonry

3.3.4 Application of this Part

Acceptable Construction Manuals

3.3.4.0 Application

Part 3.3.5 Masonry veneer

Acceptable Construction Manuals

3.3.5.0

Acceptable Construction Practice

3.3.5.1 Application

3.3.5.2 Height of wall limitation

3.3.5.3 Masonry units

3.3.5.4 Mortar mixes

3.3.5.5 Mortar joints

3.3.5.6 Cavities

3.3.5.7 Damp-proof courses and flashings — material

3.3.5.8 Damp-proof courses and flashings — installation

3.3.5.9 Weepholes

3.3.5.10 Wall ties

3.3.5.11 Openings in masonry veneer

3.3.5.12 Lintels

3.3.5.13 Vertical articulation joints

3.3.5.14 Engaged piers

Part 3.3.6 Isolated masonry piers

Acceptable Construction Manuals

3.3.6.0

Acceptable Construction Practice

3.3.6.1 Application

3.3.6.2 Piers supporting carports, verandahs, porches and similar roof structures

3.3.6.3 Piers supporting tiled roofs

3.3.6.4 Piers supporting sheet roofs

3.3.6.5 Piers for freestanding carports

3.3.6.6 Subfloor piers

Part 3.3.1 Unreinforced masonry

Appropriate *Performance Requirements*

Where an alternative masonry walling system is proposed as a *Performance Solution* to that described in [Part 3.3.1](#), that proposal must comply with—

- (a) *Performance Requirement P2.1.1*; and
- (b) the relevant *Performance Requirements* determined in accordance with [A2.2\(3\)](#) and [A2.4\(3\)](#) as applicable.

Acceptable Construction Manuals

3.3.1.0

Performance Requirement P2.1.1 is satisfied for *unreinforced masonry* (including masonry-veneer) if it is designed and constructed in accordance with one of the following:

- (a) AS 3700.
- (b) AS 4773.1 and AS 4773.2.

Explanatory information:

Composite construction: Design requirements for other materials that may be used in combination with masonry i.e. heavy steel support beams etc. are described in [Part 3.0](#) — Structural provisions.

Part 3.3.2 Reinforced masonry

Appropriate *Performance Requirements*

Where an alternative *reinforced masonry* system is proposed as a *Performance Solution* to that described in [Part 3.3.2](#), that proposal must comply with—

- (a) *Performance Requirement P2.1.1*; and
- (b) the relevant *Performance Requirements* determined in accordance with [A2.2\(3\)](#) and [A2.4\(3\)](#) as applicable.

Acceptable Construction Manuals

3.3.2.0

Performance Requirement P2.1.1 is satisfied for *reinforced masonry* if it is designed and constructed in accordance with one of the following:

- (a) AS 3700, except—
 - (i) '(for piers—isolated or engaged)' is removed from clause 8.5.1(d); and
 - (ii) where clause 8.5.1 requires design as for unreinforced masonry in accordance with Section 7, the member must also be designed as unreinforced masonry in accordance with Tables 10.3 and 4.1(a)(i)(C) of AS 3700.
- (b) AS 4773.1 and AS 4773.2.

Explanatory information:

Design requirements for other materials that may be used in combination with masonry (heavy steel support beams etc.) are described in [Part 3.0](#) — Structural provisions.

Part 3.3.3 Masonry accessories

Appropriate *Performance Requirements*

Where an alternative masonry accessory is proposed as a *Performance Solution* to that described in [Part 3.3.3](#), that proposal must comply with—

- (a) *Performance Requirement P2.1.1*; and
- (b) the relevant *Performance Requirements* determined in accordance with [A2.2\(3\)](#) and [A2.4\(3\)](#) as applicable.

Acceptable Construction Manuals

3.3.3.0

Performance Requirement P2.1.1 is satisfied for masonry accessories if they are constructed and installed in accordance with one of the following:

- (a) AS 3700.
- (b) AS 4773.1 and AS 4773.2.

Part 3.3.4 Weatherproofing of masonry

Appropriate *Performance Requirements*

Where an alternative weatherproofing system is proposed as a *Performance Solution* to that described in [Part 3.3.4](#), that proposal must comply with—

- (a) *Performance Requirement P2.2.2*; and
- (b) *Performance Requirement P2.2.3*; and
- (c) the relevant *Performance Requirements* determined in accordance with [A2.2\(3\)](#) and [A2.4\(3\)](#) as applicable.

3.3.4 Application of this Part

- (a) This Part applies to every *external wall* (including the junction between the wall and any *window* or door) of a Class 1 building.
- (b) This Part does not apply to any Class 10 building except where its construction contributes to the weatherproofing of the Class 1 building.

Acceptable Construction Manuals

3.3.4.0 Application

Performance Requirements P2.2.2 and *P2.2.3* are satisfied for weatherproofing of masonry if it is carried out in accordance with the appropriate provisions of one of the following:

- (a) AS 3700.
- (b) AS 4773.1 and AS 4773.2.

State and Territory Variations

In South Australia, delete 3.3.4.0 and insert SA 3.3.4.0 as follows:

Performance Requirement P2.2.2 and *P2.2.3* are satisfied for weatherproofing of masonry if it is carried out in accordance with the appropriate provisions of—

- (a) AS 3700 — Masonry structures; or
- (b) AS 4773 — Masonry for small buildings, Parts 1 and 2, except that metals and bitumen-coated metals referred to in clauses 7.2 and 7.3 of AS/NZS 2904 are not acceptable materials for use as *damp-proof courses* in South Australia; and
- (c) in *low rainfall intensity areas* where the site classification is A, S, M, M-D, H, H1, H2, H-D, H1-D or H2-D in accordance with AS 2870, the height of the *damp-proof course* may be —
 - (i) 15 mm above finished paved, concreted or landscaped areas; or
 - (ii) 0 mm if the *damp-proof course* is protected from the direct effects of the weather by a carport, verandah or the like.

Part 3.3.5 Masonry veneer

Appropriate *Performance Requirements*

Where an alternative masonry veneer wall system is proposed as a *Performance Solution* to that described in [Part 3.3.5](#), that proposal must comply with—

- (a) *Performance Requirement P2.1.1*; and
- (b) *Performance Requirement P2.2.2*; and
- (c) *Performance Requirement P2.2.3*; and
- (d) the relevant *Performance Requirements* determined in accordance with [A2.2\(3\)](#) and [A2.4\(3\)](#) as applicable.

Acceptable Construction Manuals

3.3.5.0

Performance Requirements P2.1.1, *P2.2.2* and *P2.2.3* are satisfied for masonry veneer if it is designed and constructed in accordance with one of the following:

- (a) AS 3700.
- (b) AS 4773.1 and AS 4773.2.

Acceptable Construction Practice

3.3.5.1 Application

Compliance with this acceptable construction practice satisfies *Performance Requirements P2.1.1*, *P2.2.2* and *P2.2.3* for masonry veneer provided—

- (a) the building is located in an area with a *design wind speed* of not more than N3; and
- (b) masonry veneer walls are constructed on footings that comply with [Part 3.2](#); and
- (c) the building *site* soil classification is A, S or M; and
- (d) the framing that the masonry wall is tied to complies with [Parts 3.4](#) and [3.0](#) as appropriate; and
- (e) the building is not constructed in an *alpine area*; and
- (f) the building is one for which Appendix A of AS 1170.4 contains no specific earthquake design requirements.

3.3.5.2 Height of wall limitation

Masonry veneer walls must not be greater than 8.5 m in height when measured above the adjacent finished ground level.

3.3.5.3 Masonry units

- (a) Masonry units must have a minimum characteristic unconfined compressive strength of—
 - (i) 3 MPa for solid or cored units; or
 - (ii) 10 MPa for hollow units.
- (b) Masonry veneer walls must have a minimum veneer thickness of 90 mm.
- (c) Subject to (d), masonry units must be—
 - (i) either clay or calcium silicate brick or concrete brick or block; and
 - (ii) classified and used in the exposure conditions appropriate to their classification as described in [Table 3.3.5.1](#).

Table 3.3.5.1 Exposure conditions

Exposure classification	Masonry application
Protected (P)	Suitable for use in locations such as—

Masonry

Exposure classification	Masonry application
	<ol style="list-style-type: none"> internal walls; and <i>external walls</i> that are coated or rendered; and walls above <i>damp-proof courses</i> provided the wall is protected at the top by a roof, eaves, coping, topping or the like.
General purpose (GP)	Suitable for use in all locations except those where 'Exposure class' is <i>required</i> .
Exposure class (Exp)	Suitable for use in all locations including severe local conditions such as— <ol style="list-style-type: none"> below the <i>damp-proof course</i> in areas where walls are expected to be attacked by salts in the ground water or brickwork itself (salt attack or salt damp); and on sea fronts where walls are exposed to attack from salt spray; and in heavily polluted areas subject to deposition of atmospheric pollution; and under regular cyclic freeze and thaw conditions.

Explanatory information:

The exposure classification or durability of a masonry unit is a measure of its resistance to attack by soluble salts, either in the ground or in the atmosphere. All masonry products manufactured are classified by their durability. The majority of uses will require either an Exposure class (Exp) product or a General Purpose (GP) product.

- (d) Mixing of panels consisting of clay masonry units with panels consisting of concrete or calcium silicate masonry units is not permitted unless—
- at vertical junctions, a control joint is installed; and
 - at horizontal junctions between panels of different materials, a slip joint using a membrane similar to that used for *damp-proof courses* is installed.

3.3.5.4 Mortar mixes

Mortar used for masonry construction must comply with AS 3700 or AS 4773 except that the mortar may be mixed by volume in the proportions stated in [Table 3.3.5.2](#).

Table 3.3.5.2 Acceptable mortar mixes

Brick exposure classification	Mortar mix by volume ^{Note 1}	
	Cement:lime:sand	
	General use	Suitable for concrete masonry ^{Note 2}
Protected	1:2:9	1:0:5
General purpose	1:1:6	1:0:5
Exposure class	1:0.5:4.5	1:0:4.2

Notes to Table 3.3.5.2:

- Additives may be used provided they comply with the appropriate specified rate.
- Mortar mixes for masonry require the use of methyl cellulose water thickener.

3.3.5.5 Mortar joints

- Unless otherwise specified, masonry bed and perpend joints must have a nominal thickness of 10 mm.
- Where raked joints are used they must not be—
 - raked deeper than 10 mm; or
 - used in saline environments or areas subject to heavy industrial airborne pollution.

3.3.5.6 Cavities

The clear width of a *cavity* between the masonry veneer and the exterior face of the supporting frame must be not less than 25 mm wide and where the masonry veneer is constructed on a slab-on-ground, the *cavity* must be drained to the outside in accordance with 3.3.5.9.

Explanatory information:

The 25 mm clear width of the *cavity* needs to be maintained regardless of any wall membranes, sheet bracing or services installed to the supporting frame.

3.3.5.7 Damp-proof courses and flashings — material

Damp-proof courses and *flashings* must consist of—

- (a) a material that complies with AS/NZS 2904; or
- (b) embossed black polyethylene film of high impact resistance and low slip, with a nominal thickness of 0.5 mm prior to embossing, and comply with clause 7.6 of AS/NZS 2904; or
- (c) polyethylene coated metal, that has an aluminium core of not less than 0.1 mm thick, is coated both sides with bitumen adhesive enclosed in polyethylene film of not less than 0.1 mm thick on each face, and has a nominal total thickness of not less than 0.5 mm prior to embossing; or
- (d) bitumen impregnated materials of not less than 2.5 mm thick, that comply with clause 7.5 of AS/NZS 2904; or
- (e) termite sheet materials complying with Part 3.1.4 (with no penetrations) serving the purpose of a *damp-proof course* and/or *flashing* that is continuous through the wall or pier.

3.3.5.8 Damp-proof courses and flashings — installation

(a) *Damp-proof courses* and *flashings* must be—

(i) located so as to form a continuous damp-proofing barrier—

- (A) around the bottom perimeter of walls where constructed on a concrete slab; and
- (B) in walls and piers below suspended floors; and
- (C) where a masonry wall passes through a roof; and
- (D) where a roof abuts an external masonry wall; and
- (E) to the bottom and tops of *windows* and doors and the like in accordance with (c), except a *damp-proof course* or a *flashing* need not be provided to the top of a *window* or door where the opening is protected by an eave of a width more than 3 times the height of the masonry veneer above the opening; and

(ii) continuous through the wall or pier and be visible from the outside face of the wall.

(b) The location of a *damp-proof course* or *flashing* serving as a *damp-proof course*, must be not less than—

- (i) 150 mm above the adjacent ground level; or
- (ii) 75 mm above the finished surface level of adjacent paved, concreted or landscaped areas that slope away from the wall; or
- (iii) 50 mm above finished paved, concreted or landscaped areas complying with 3.1.3.3(b)(ii) and protected from the direct effects of the weather by a carport, verandah or the like; or
- (iv) in *low rainfall intensity areas*—
 - (A) 15 mm above finished paved, concreted or landscaped areas; or
 - (B) 0 mm above finished paved, concreted or landscaped areas if the *damp-proof course* is protected from the direct effects of the weather by a carport, verandah or the like.

(c) Sill and head *flashings* serving openings must be—

- (i) installed so that the *flashing* extends not less than 150 mm beyond the reveals on each side of the opening; and
- (ii) located not more than—
 - (A) one course below the sill brick course; and

Masonry

- (B) 300 mm above the opening; and
- (iii) turned up in the *cavity* not less than 150 mm above the opening; and
- (iv) embedded not less than 30 mm into the masonry veneer; and
- (v) attached to the *window* or wall framing.

3.3.5.9 Weepholes

- (a) Except where excluded by (b), open perpendicular joints (weepholes) must be created in the course immediately above any *flashing* (including above any *damp-proof course* acting as a *flashing*) and be—
 - (i) a minimum of 50 mm in height, by the width of the vertical mortar joint; and
 - (ii) at not more than 1.2 m centres; and
- (b) Weepholes are not *required* in the following locations:
 - (i) Where head openings are less than 1.2 m wide.
 - (ii) Beneath *window* and door sills.

3.3.5.10 Wall ties

Veneer wall ties must—

- (a) comply with AS/NZS 2699.1 and be—
 - (i) light duty veneer ties in areas where the *design wind speed* is not more than N2; and
 - (ii) medium duty ties—
 - (A) in areas where the *design wind speed* is more than N2; and
 - (B) where engaged piers are provided; and
- (b) be spaced and fixed in accordance with [Table 3.3.5.3a](#) and [Table 3.3.5.3b](#); and
- (c) be protected against corrosion in accordance with [Table 3.3.5.4](#).

Table 3.3.5.3a Wall tie spacings

Maximum spacings	450 mm wall stud spacing	600 mm wall stud spacing
Horizontal	Maximum 450 mm centres	Maximum 600 mm centres
Vertical	Maximum 400 mm	Maximum 400 mm

Table 3.3.5.3b Placement of wall ties

Location	Placement of wall ties
Unsupported panel sides and edges of openings	Within 300 mm of panel side or edge
Top of veneer panels and top of panels under openings	Within 300 mm or two courses (whichever is the lesser) of the top of veneer
(a) Bottom of veneer panel in masonry rebate sealed with liquid applied <i>damp-proof course</i>	Within 300 mm or two courses (whichever is the lesser) from the bottom of the veneer
(b) Bottom of veneer panel supported on steel lintel	
Bottom of veneer panel in masonry rebate with membrane <i>damp-proof course</i>	In each of the first two courses
Where articulation joints occur	At both sides of the articulation joint within 300 mm from the joint
Engaged piers	Within 200 mm of the top of the pier

Note to Table 3.3.5.3b: Ties are to be fixed to the supporting frame at all regular stud positions using screws or nails.

Masonry

Table 3.3.5.4 Corrosion protection for wall ties

Exposure condition	Tie specification - minimum corrosion protection
Areas— (a) less than 1 km from <i>breaking surf</i> ; or (b) less than 100 m from salt water not subject to <i>breaking surf</i> ; or (c) within heavy industrial areas.	<ul style="list-style-type: none"> Grade 316L stainless steel; or engineered polymer complying with the requirements of AS/NZS 2699.1.
Areas— (a) 1 km or more but less than 10 km from <i>breaking surf</i> ; or (b) 100 m or more but less than 1 km from salt water not subject to <i>breaking surf</i> .	<ul style="list-style-type: none"> Sheet steel and bar ties galvanised after manufacture - 470 g/m² on each side; or galvanised wire ties - 470 g/m² coating mass; or Grade 304L stainless steel.
All other areas	<ul style="list-style-type: none"> Galvanised sheet steel - 300 g/m² coating on each side; or sheet steel ties galvanised after manufacture - 300 g/m² on each side.

Explanatory information:

Wall ties that are suitable for use in a more severe exposure condition are also suitable for use in less severe exposure conditions, i.e. stainless steel and engineered polymer ties are suitable for use in all conditions and 470g/m² galvanised ties can be used in all exposure conditions except the most severe.

3.3.5.11 Openings in masonry veneer

- (a) Except where excluded by (b), openings in masonry veneer must be spanned by steel lintels.
- (b) Openings in masonry veneer not more than 500 mm wide need not be provided with a steel lintel provided the opening is adequately supported.

3.3.5.12 Lintels

Where a lintel is *required* it must comply with the following:

- (a) Steel lintels must comply with this Part or Part 3.4.4.
- (b) Steel lintels must—
- be sized in accordance with Table 3.3.5.5; and
 - be installed with the long leg of lintel angle vertical; and
 - not carry more than a 110 mm thick veneer; and
 - not carry masonry more than 3 m in height when measured above the opening; and
 - have a minimum bearing length at each end of the lintel of—
 - for clear spans not more than 1 m - 100 mm; or
 - for clear spans more than 1 m - 150 mm (See Figure 3.3.5.2); and
 - have a minimum of three courses of masonry over openings; and
 - comply with the corrosion protection requirements of Table 3.3.5.6.

Table 3.3.5.5 Masonry veneer lintel sizes

Lintel	Maximum clear span of lintel (mm):	
	≤ 600 mm of masonry over opening	> 600 mm of masonry over opening
Flat 75 x 8	700	700
Flat 100 x 10	900	900
Angle 90 x 90 x 6EA	3000	2650

Masonry

Lintel	Maximum clear span of lintel (mm):	
	≤ 600 mm of masonry over opening	> 600 mm of masonry over opening
Angle 90 x 90 x 8EA	3200	2800
Angle 100 x 100 x 6EA	3350	2900
Angle 100 x 100 x 8EA	3600	3040
Angle 150 x 90 x 8UA	4200	3850

Note to Table 3.3.5.5: The lintels described in this Table must be not less than grade 300 MPa in accordance with AS 4100.

Table 3.3.5.6 Corrosion protection - Lintels

Durability class of lintel in accordance with AS/NZS 2699.3 ^{Note 1}	Material or protective requirements in accordance with AS/NZS 2699.3 ^{Note 1}
R1 R2	Hot dip galvanised with a minimum average coating thickness of 300 g/m ² ; or stainless steel 316L
R3	Hot dip galvanised with a minimum average coating thickness of 600 g/m ² ; or stainless steel 316L
R4	Stainless steel 316L

Notes to Table 3.3.5.6:

- AS/NZS 2699.3 contains information on the corrosivity category locations in Australia and provides a method for determining coating thickness for lintels.
- Additional decorative coatings can be applied, but must not be considered for the purpose of satisfying the requirements of this Table.
- Any lintel with a coating that is modified, i.e. by cutting, welding, or where damaged, must have the coating restored to provide an equivalent level of protection provided by the original coating.

Masonry

Figure 3.3.5.2 Lintel installation

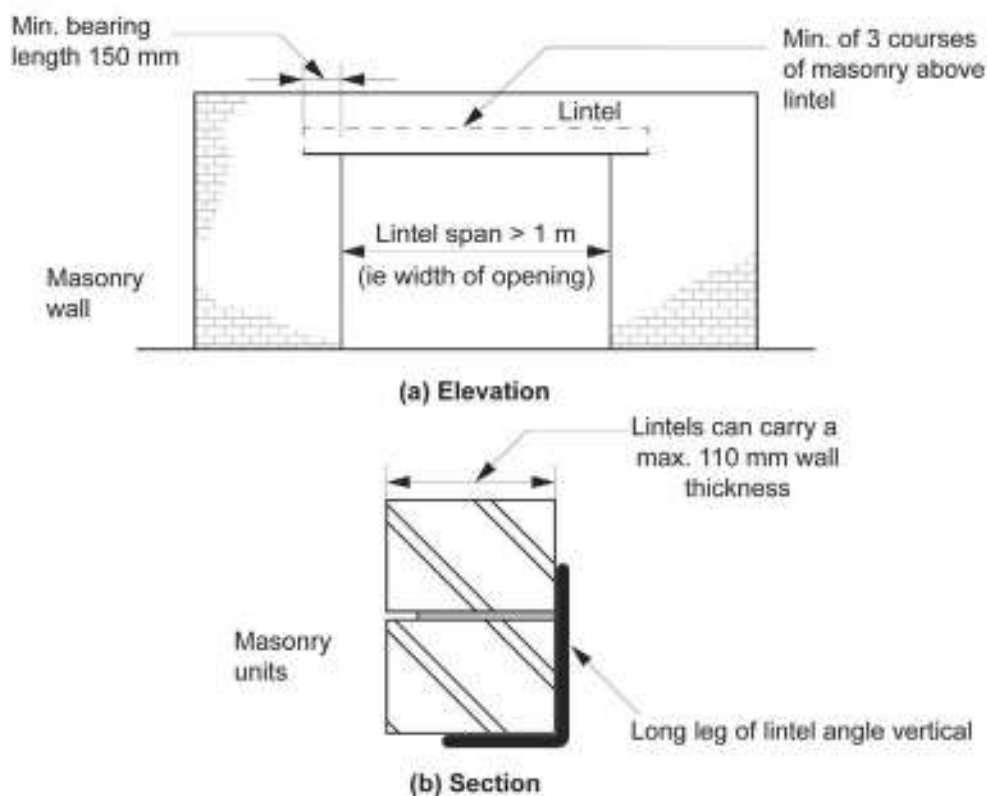

3.3.5.13 Vertical articulation joints

- (a) Vertical articulation joints must be provided in masonry veneer walls in accordance with (b), except in walls constructed on *sites* where the soil classification is A or S (see Part 3.2.4).

Explanatory information:

For the purposes of 3.3.5.13, the vertical articulation joint also performs the function of a contraction or expansion joint.

- (b) Articulation joints between masonry elements must have a width of not less than 10 mm and be provided (see Figures 3.3.5.3, 3.3.5.4 and 3.3.5.5)—
- in straight, continuous walls having no openings — at not more than 6 m centres and within 4.5 m, but not closer than 470 mm of all corners; and
 - in straight, continuous walls with openings more than 900 x 900 mm — at not more than 5 m centres and located so that they are not more than 1.2 m away from openings; and
 - where the height of the wall changes by more than 20% — at the position of change in height; and
 - where a wall changes in thickness; and
 - at control or construction joints in footings or slabs; and
 - at junctions of walls constructed of different masonry materials.
- (c) Articulation joints must not be constructed adjacent to arched openings.
- (d) Articulation joints must either be filled with—
- a compressible foam or polystyrene filler and a flexible sealant; or
 - a purpose made backer rod and a flexible sealant (see Figure 3.3.5.5).

Masonry

Figure 3.3.5.3 Example of vertical articulation joint locations in plan view

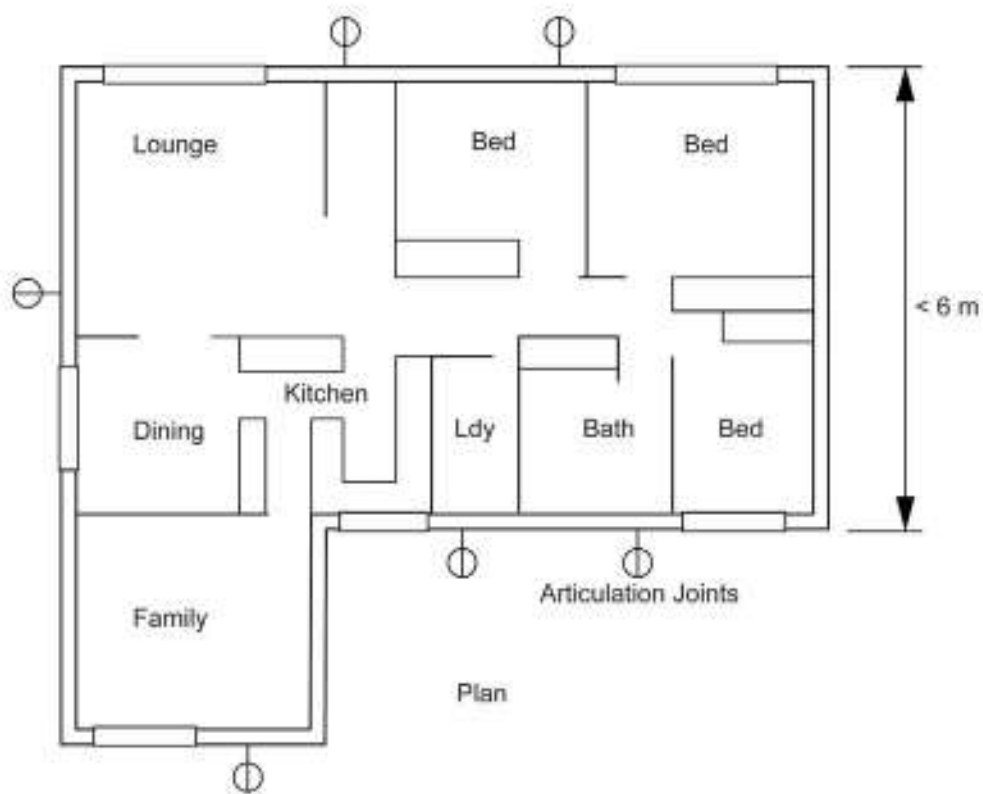

Figure 3.3.5.4 Vertical articulation joints

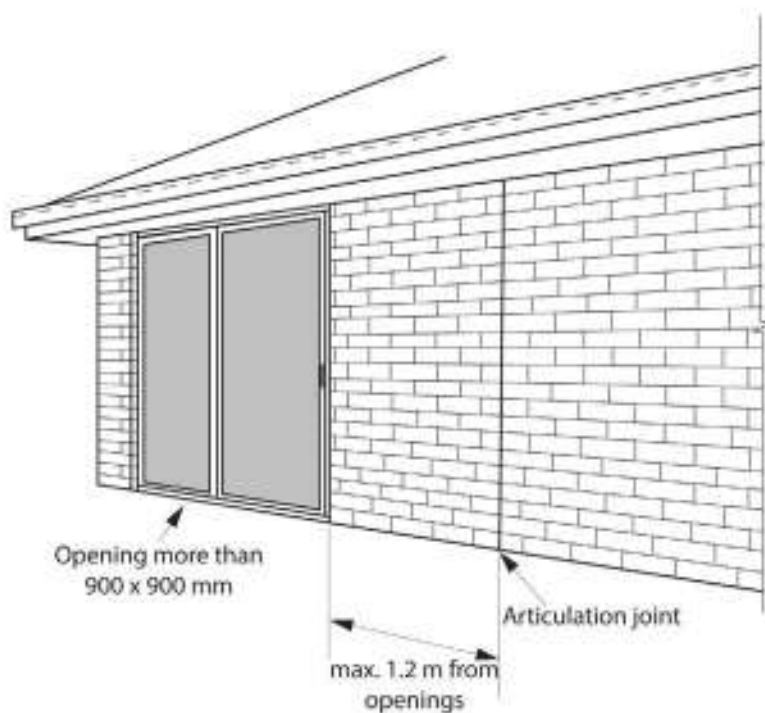

Figure 3.3.5.5 Vertical articulation joint details

Diagram a. Articulation joint with compressible foam and sealant

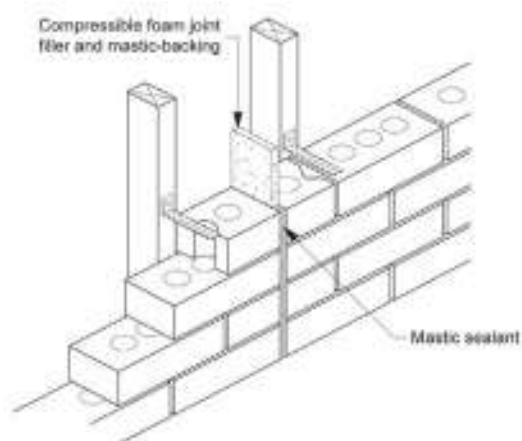
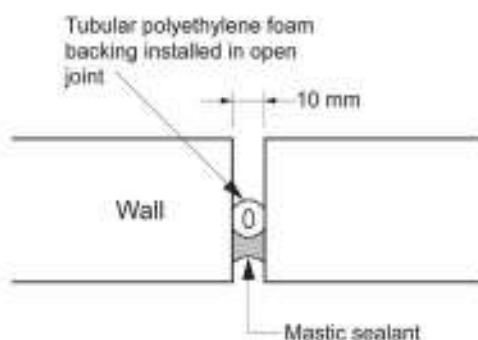

Diagram b. Articulation joint with backer rod and sealant



Note to Figure 3.3.5.5: Joints and sealants may be painted to reduce visual impact.

3.3.5.14 Engaged piers

Where engaged piers are installed to support subfloor framing, they must comply with the provisions of this Part and be constructed as follows:

- (a) Footings for piers must comply with [Part 3.2](#).
- (b) Engaged piers must not support more than a single storey with a roof framing span of not more than 12 m.
- (c) Piers must be spaced at not more than 3 m centres with floor framing complying with—
 - (i) [Part 3.4.2](#) for steel framing; and
 - (ii) [Part 3.4.3](#) for timber framing; and
 - (iii) [Part 3.4.4](#) for structural steel framing.
- (d) Piers must be—
 - (i) not more than 1.2 m high; and
 - (ii) a minimum thickness of 100 mm inclusive of mortar; and
 - (iii) a width greater than the depth of the timber or steel section which it is supporting (See [Figure 3.3.5.6](#)).
- (e) Notwithstanding (c), engaged piers must be located beneath—
 - (i) each side of *window* and door openings; and
 - (ii) concentrated roof loads, inclusive of any roof beams and girder trusses.
- (f) Piers must be tied or bonded to the external masonry wall, and where ties are used they must comply with [3.3.5.10](#).

Masonry

(g) Piers formed from hollow-core masonry units must be filled with grout.

Figure 3.3.5.6 Engaged pier

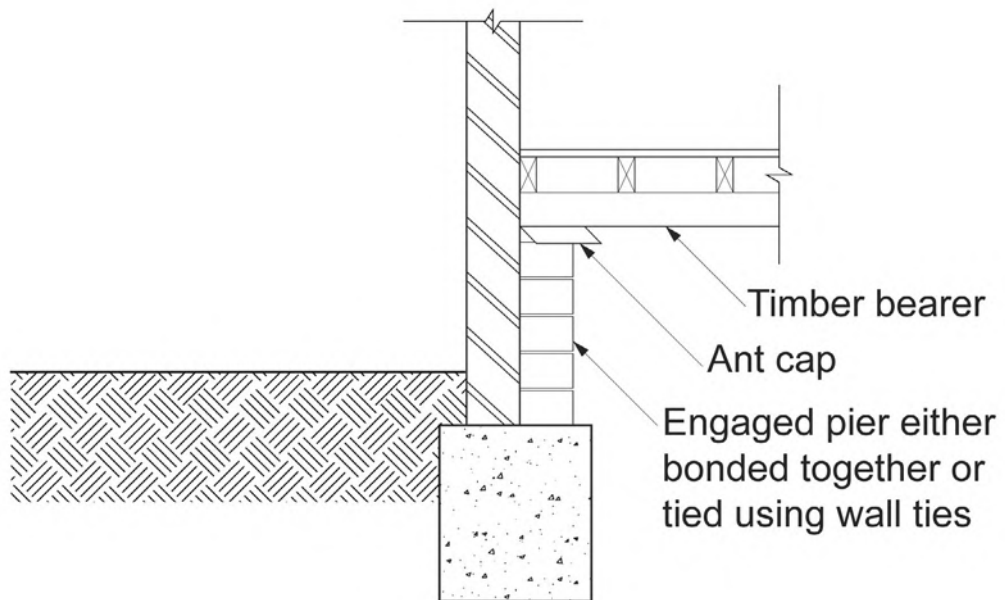

Part 3.3.6 Isolated masonry piers

Appropriate *Performance Requirements*

Where an alternative isolated masonry pier system is proposed as a *Performance Solution* to that described in [Part 3.3.6](#), that proposal must comply with—

- (a) *Performance Requirement P2.1.1*; and
- (b) the relevant *Performance Requirements* determined in accordance with [A2.2\(3\)](#) and [A2.4\(3\)](#) as applicable..

Acceptable Construction Manuals

3.3.6.0

Performance Requirement P2.1.1 is satisfied for an isolated masonry pier system if it is designed and constructed in accordance with one of the following, as appropriate:

- (a) AS 3700, except—
 - (i) '(for piers—isolated or engaged)' is removed from clause 8.5.1(d); and
 - (ii) where clause 8.5.1 requires design as for unreinforced masonry in accordance with Section 7, the member must also be designed as unreinforced masonry in accordance with Tables 10.3 and 4.1(a)(i)(C) of AS 3700.
- (b) AS 4773.1 and AS 4773.2.

Acceptable Construction Practice

3.3.6.1 Application

Compliance with this acceptable construction practice satisfies *Performance Requirement P2.1.1* for an isolated masonry pier system provided—

- (a) the building is located in an area with a *design wind speed* of not more than N3; and
- (b) isolated piers are constructed on footings that comply with [Part 3.2](#); and
- (c) masonry units comply with [3.3.5.3\(c\)](#) and have a minimum compressive strength of—
 - (i) 6.2 MPa for solid or cored units; or
 - (ii) 15 MPa for hollow units; and
- (d) the roof structure and any walls provide the *required* lateral bracing for the top of the isolated pier when determined in accordance with AS 3700, except—
 - (i) '(for piers—isolated or engaged)' is removed from clause 8.5.1(d); and
 - (ii) where clause 8.5.1 requires design as for unreinforced masonry in accordance with Section 7, the member must also be designed as unreinforced masonry in accordance with Tables 10.3 and 4.1(a)(i)(C) of AS 3700; and
- (e) the building *site* soil classification is either A, S or M; and
- (f) the building is not constructed in an *alpine area*; and
- (g) the building is one for which Appendix A of AS 1170.4 contains no specific earthquake design requirements.

3.3.6.2 Piers supporting carports, verandahs, porches and similar roof structures

Isolated piers supporting carports, verandahs, porches and similar roof structures, or vehicle access door openings, which form part of the main roof, or are attached to a wall of a Class 1 building must—

- (a) be not less than 290 x 290 mm in section; and
- (b) be not more than 2.7 m high (see [Figure 3.3.6.1](#)); and
- (c) be spaced at not more than 3 m centres (see [Figure 3.3.6.1](#)); and

- (d) provide a bearing length of not less than 150 mm for any supported members; and
- (e) comply with the relevant provisions of this Part.

3.3.6.3 Piers supporting tiled roofs

Isolated piers supporting tiled roofs must have—

- (a) a built-in 32 x 0.8 mm galvanised steel strap fixed to the roof structure that extends the full height of the pier; and
- (b) a 4.6 grade M12 galvanised steel rod which is cast into the footing when poured and looped and fixed around the galvanised steel strap *required* by (a).

3.3.6.4 Piers supporting sheet roofs

Isolated piers supporting sheet roofs must have—

- (a) a built-in 32 x 0.8 mm galvanised steel strap fixed to the roof structure extending the full height of the pier which is looped and fixed around a 4.6 grade 16 mm diameter galvanised steel rod cast into the footing when poured; or
- (b) a 4.6 grade M16 galvanised steel rod cast into the footing, threaded at the top and extending the full height of the pier to connect to the roof structure.

3.3.6.5 Piers for freestanding carports

Piers for freestanding carports must—

- (a) be not less than 290 x 290 mm with the central core filled with 20 MPa concrete, or an exposure class mortar (see [Table 3.3.5.2](#)) complying with [3.3.5.4](#); and
- (b) have the core reinforced with one Y16 steel reinforcing rod cast into the footing and extending the full height of the pier to connect to the roof structure.

Figure 3.3.6.1 Piers under main roof

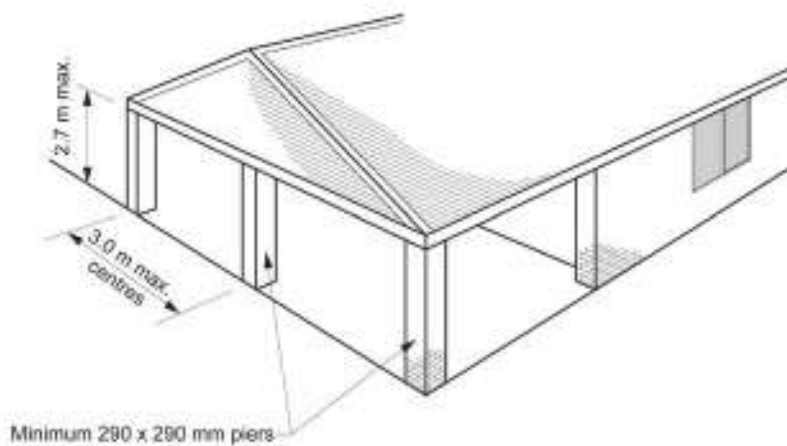

3.3.6.6 Subfloor piers

- (a) Subfloor isolated piers must be a minimum of 190 x 190 mm in section and comply with [Figure 3.3.6.2](#) for height requirements.

Masonry

Figure 3.3.6.2 Sub-floor isolated piers - maximum height and sectional details

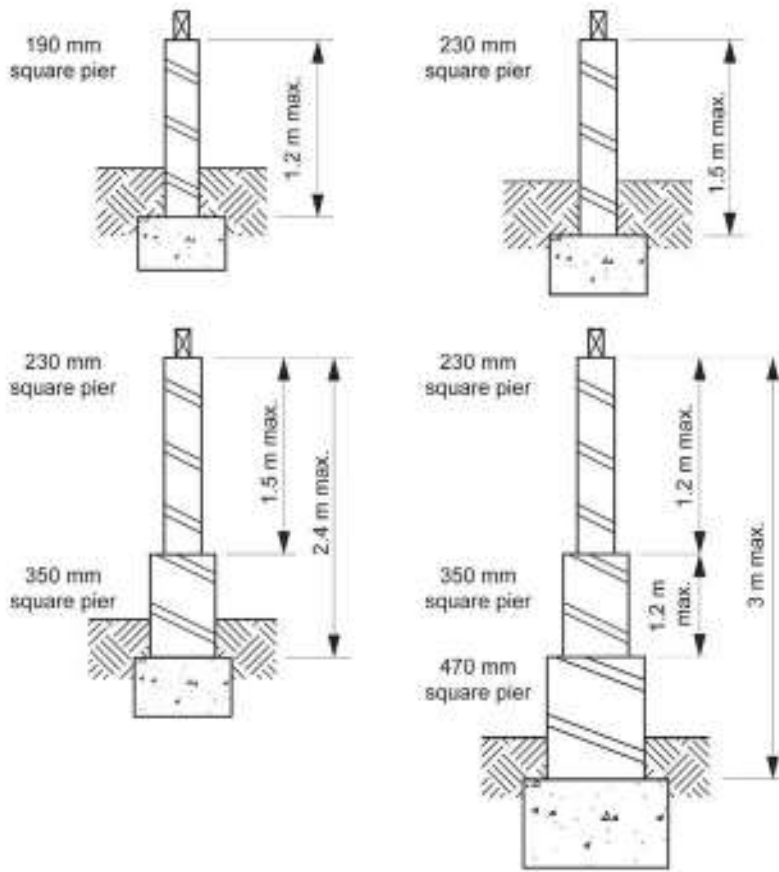

Framing

- Part 3.4.0** **Framing**
- Part 3.4.1** **Subfloor ventilation**
- Part 3.4.2** **Steel framing**
- Part 3.4.3** **Timber framing**
- Part 3.4.4** **Structural steel members**

Part 3.4 Framing

Part 3.4.0 Framing

- 3.4.0.1 Explanation of terms
- 3.4.0.2 Structural software

Part 3.4.1 Subfloor ventilation

Acceptable Construction Practice

- 3.4.1.1 Application
- 3.4.1.2 Subfloor ventilation

Part 3.4.2 Steel framing

Acceptable Construction Manuals

- 3.4.2.0 Application

Part 3.4.3 Timber framing

Acceptable Construction Manuals

- 3.4.3.0

Part 3.4.4 Structural steel members

Explanation of Terms

- 3.4.4

Acceptable Construction Manuals

- 3.4.4.0 Application

Acceptable Construction Practice

- 3.4.4.1 Application
- 3.4.4.2 Structural steel members
- 3.4.4.3 Columns
- 3.4.4.4 Corrosion protection

Part 3.4.0 Framing

3.4.0.1 Explanation of terms

The following diagrams depict framing members and associated terminology used to describe them in the [Housing Provisions](#).

In most cases the terminology is applicable for both steel and timber frame members.

Figure 3.4.0.1 Span and spacing terms

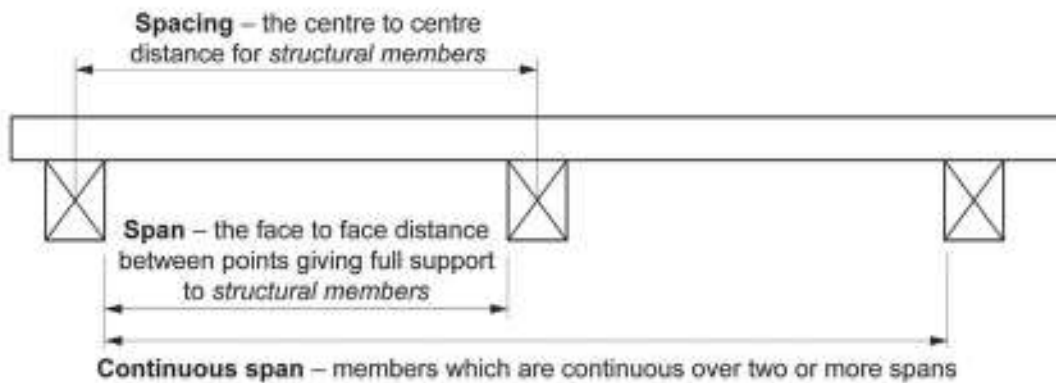
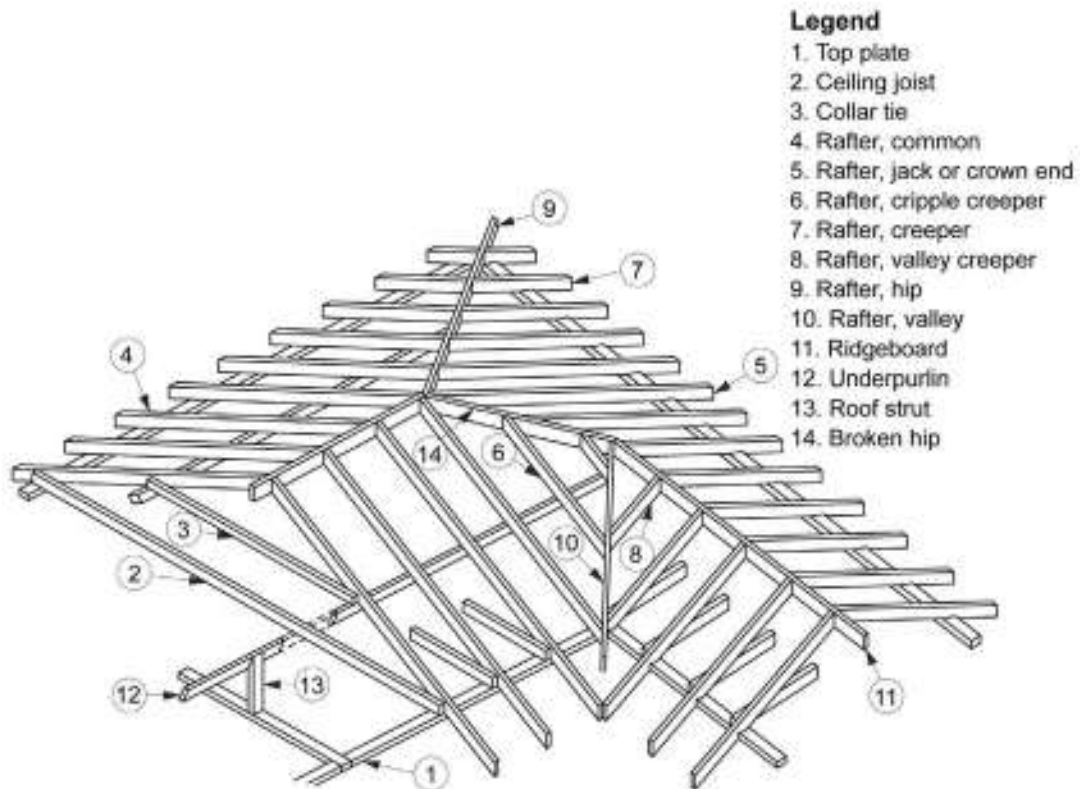
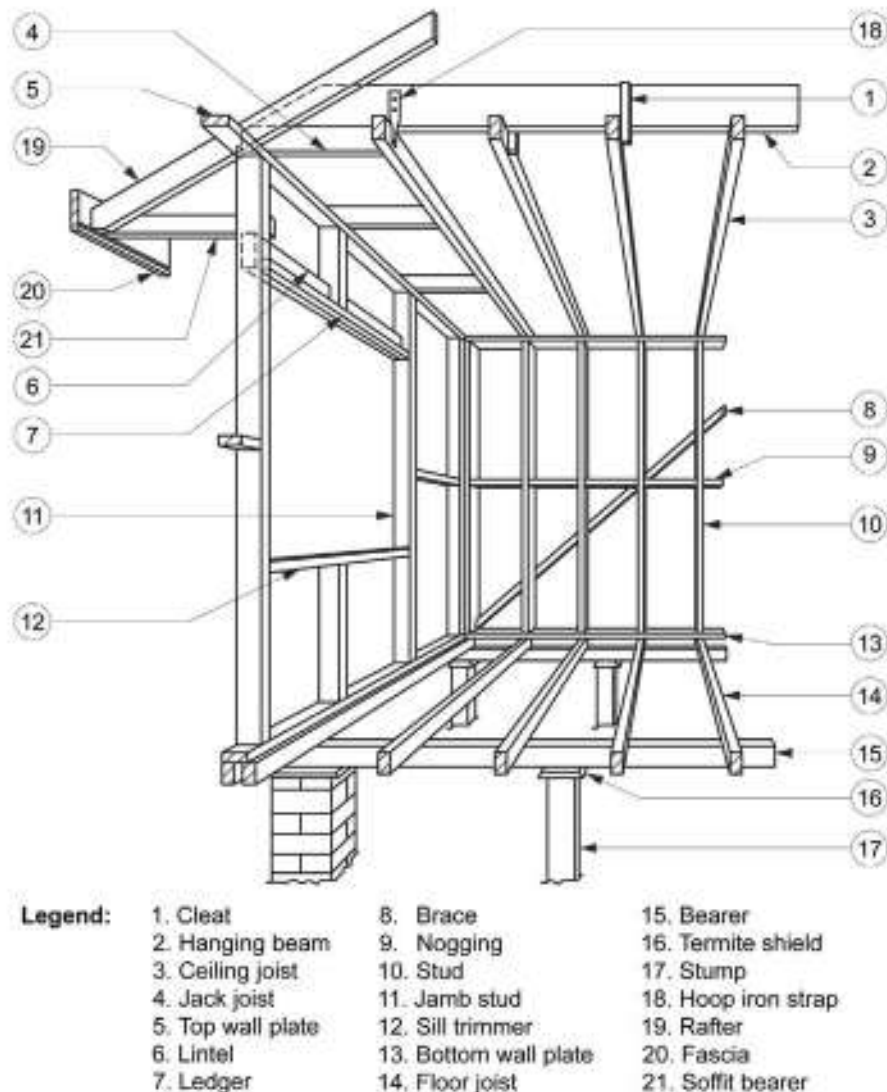

Figure 3.4.0.2 Typical roof framing members



Framing

Figure 3.4.0.3



3.4.0.2 Structural software

- (a) Structural software used in computer aided design of a building or structure, that uses design criteria based on the *Deemed-to-Satisfy Provisions* of the *Housing Provisions*, including its referenced documents, for the design of steel or timber trussed roof and floor systems and framed building systems, must comply with the ABCB Protocol for Structural Software.
- (b) Structural software referred to in (a) can only be used for buildings within the following geometrical limits:
- (i) The distance from ground level to the underside of eaves must not exceed 6 m.
 - (ii) The distance from ground level to the highest point of the roof, neglecting chimneys, must not exceed 8.5 m.
 - (iii) The building width including roofed verandahs, excluding eaves, must not exceed 16 m.
 - (iv) The building length must not exceed five times the building width.
 - (v) The roof pitch must not exceed 35 degrees.
- (c) The requirements of (a) do not apply to design software for individual frame members such as electronic tables similar to those provided in—
- (i) AS 1684; or
 - (ii) NASH Standard – Residential and Low-Rise Steel Framing, Part 2.

Explanatory information:

3.4.0.2 does not apply where a software package simply eliminates manual calculations and the process of the package requires identical methodology as that undertaken manually e.g. AS 1684 span tables and bracing calculations.

Part 3.4.1 Subfloor ventilation

Appropriate *Performance Requirements*

Where an alternative subfloor ventilation system is proposed as a *Performance Solution* to that described in [Part 3.4.1](#), that proposal must comply with—

- (a) *Performance Requirement P2.2.3*; and
- (b) the relevant *Performance Requirements* determined in accordance with [A2.2\(3\)](#) and [A2.4\(3\)](#) as applicable.

Explanatory information:

[Part 3.4.1](#) applies to the subfloor space of all suspended floors of a building or deck, including but not limited to, timber and steel-framed subfloors and suspended concrete slabs.

Acceptable Construction Practice

3.4.1.1 Application

Compliance with this acceptable construction practice satisfies *Performance Requirement P2.2.3* for subfloor ventilation.

3.4.1.2 Subfloor ventilation

- (a) Subfloor spaces must—
 - (i) be provided with openings in *external walls* and internal subfloor walls in accordance with [Table 3.4.1.1](#) for the climatic zones given in [Figure 3.4.1](#); and
 - (ii) have clearance between the ground surface and the underside of the lowest horizontal member in the subfloor in accordance with [Table 3.4.1.1](#) (see [Figure 3.4.3a](#) and [Figure 3.4.3b](#)).

Table 3.4.1.1 Subfloor openings

Climatic zone (see Figure 3.4.1)	Minimum aggregate subfloor ventilation openings with no membrane (mm ² /m of wall)	Minimum aggregate subfloor ventilation openings with ground sealed with impervious membrane (mm ² /m of wall)
A	2000	1000
B	4000	2000
C	6000	3000

Note to [Table 3.4.1.1](#): In situations where openings in *external walls* and internal subfloor walls, including *separating walls*, are not able to be provided, additional measures must be provided to ensure that the overall level of ventilation of the subfloor space is maintained. This may include measures similar to those in [3.4.1.2\(e\)](#) i.e. providing durability class timbers, or having the ground sealed in the subfloor space with an impervious membrane.

Table 3.4.1.2 Ground clearance

Climatic zone (see Figure 3.4.1)	Minimum ground clearance height where termite inspection or management system is not <i>required</i> (mm)	Minimum ground clearance height where termite inspection is <i>required</i> (mm)
A, B and C	150	400

Notes to [Table 3.4.1.2](#):

1. 400 mm clearance *required* only where termite management systems are installed that need to be inspected (see [Part 3.1.4](#)).
2. On sloping *sites* the 400 mm clearance *required* by 1. may be reduced to 150 mm within 2 m of *external walls* in accordance with [Figure 3.4.3a](#).

Framing

Figure 3.4.1 Climatic zones based on relative humidity

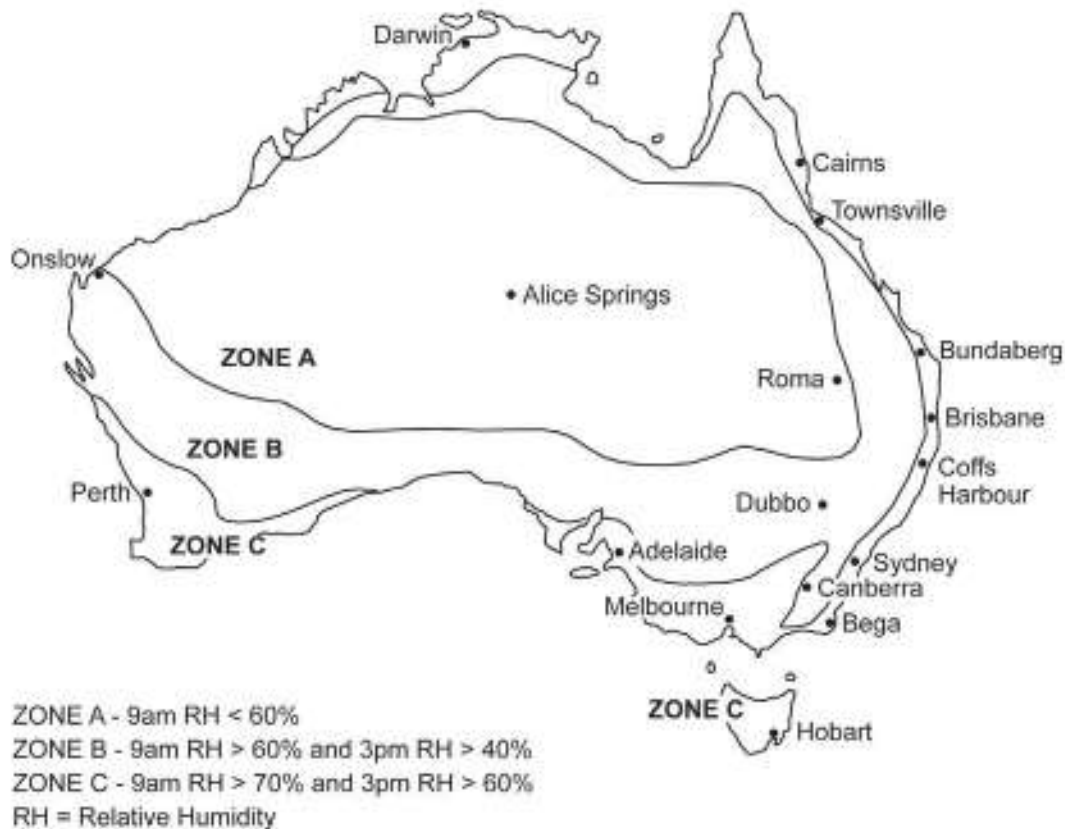

- (b) In addition to (a), a subfloor space must—
- (i) be cleared of all building debris and vegetation; and
 - (ii) have the ground beneath the suspended floor graded in accordance with 3.1.3.3; and
 - (iii) contain no dead air spaces; and
 - (iv) have openings evenly spaced as far as practicable (see Figure 3.4.2); and
 - (v) have openings placed not more than 600 mm in from corners.
- (c) In double leaf masonry walls, openings specified in (a) must be provided in both leaves of the masonry, with openings being aligned to allow an unobstructed flow of air (see Figure 3.4.2).
- (d) Openings in internal subfloor walls specified in (a) must have an unobstructed area equivalent to that *required* for the adjacent external openings (see Figure 3.4.2).
- (e) Where the ground or subfloor space is excessively damp or subject to frequent flooding, in addition to the requirements of (a) to (d)—
- (i) the subfloor ventilation *required* in (a) must be increased by 50%; or
 - (ii) the ground within the subfloor space must be sealed with an impervious membrane; or
 - (iii) subfloor framing must be—
 - (A) where above ground — above ground durability Class 1 or 2 timbers or H3 preservative treated timbers in accordance with AS 1684.2, AS 1684.3 or AS 1684.4; or
 - (B) where in-ground — in-ground durability Class 1 or 2 timbers or H5 preservative treated timbers in accordance with AS 1684.2, AS 1684.3 or AS 1684.4; or
 - (C) steel in accordance with NASH Standard 'Residential and Low-Rise Steel Framing' Part 2.

Explanatory information:

Framing

3.4.1.2(e) specifies additional requirements for preventing deterioration of subfloor members where the ground or subfloor space is excessively damp, as would occur in areas with high water tables, poor drainage or in areas frequently affected by flooding or water inundation.

Figure 3.4.2 Typical subfloor ventilation details—Typical cross ventilation of subfloor area

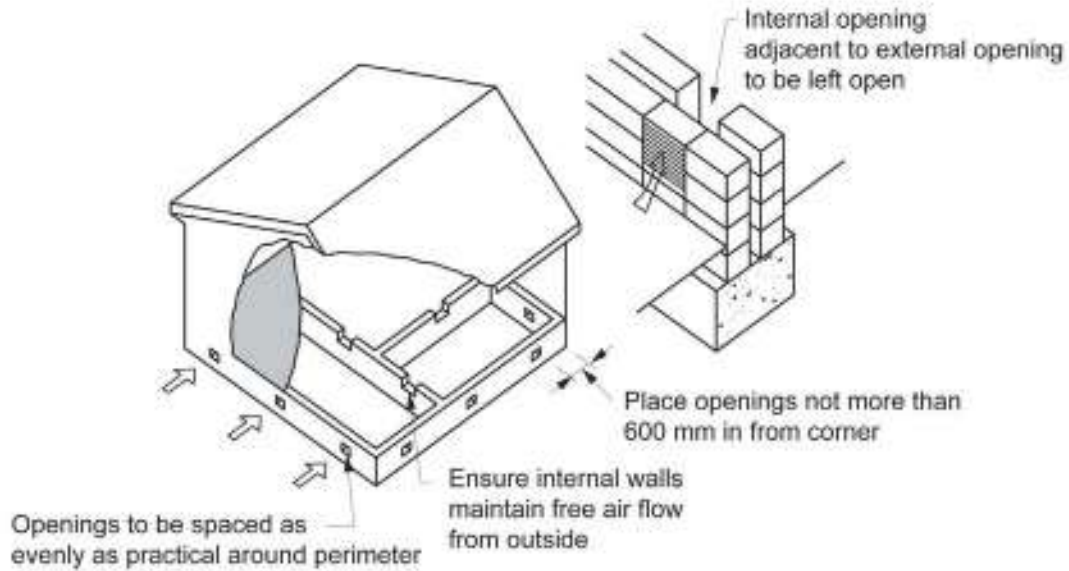
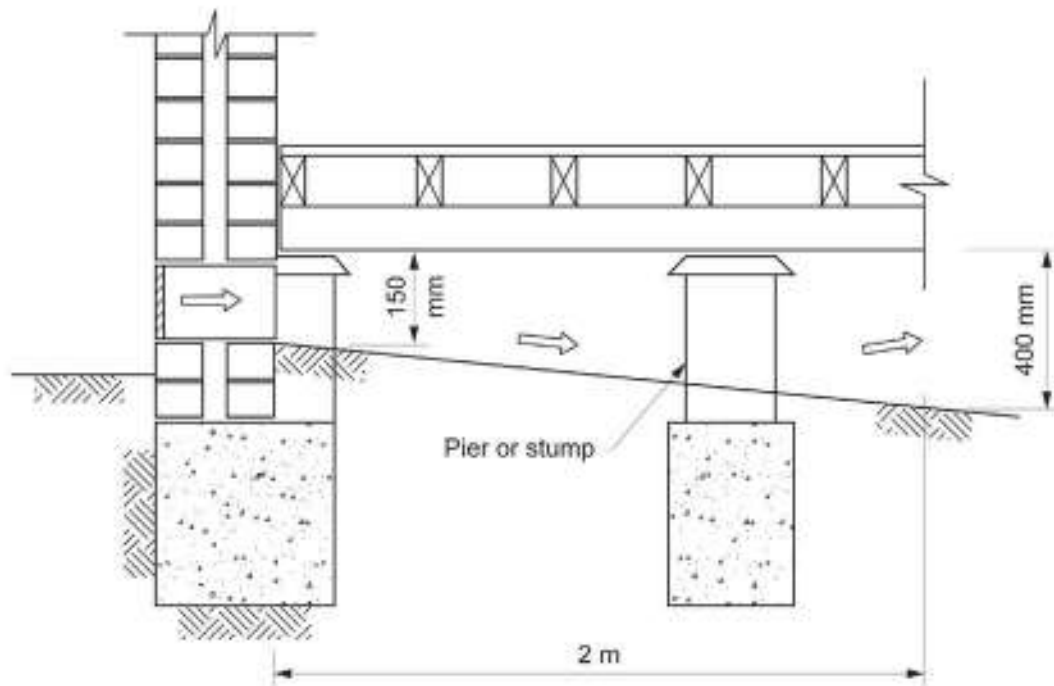
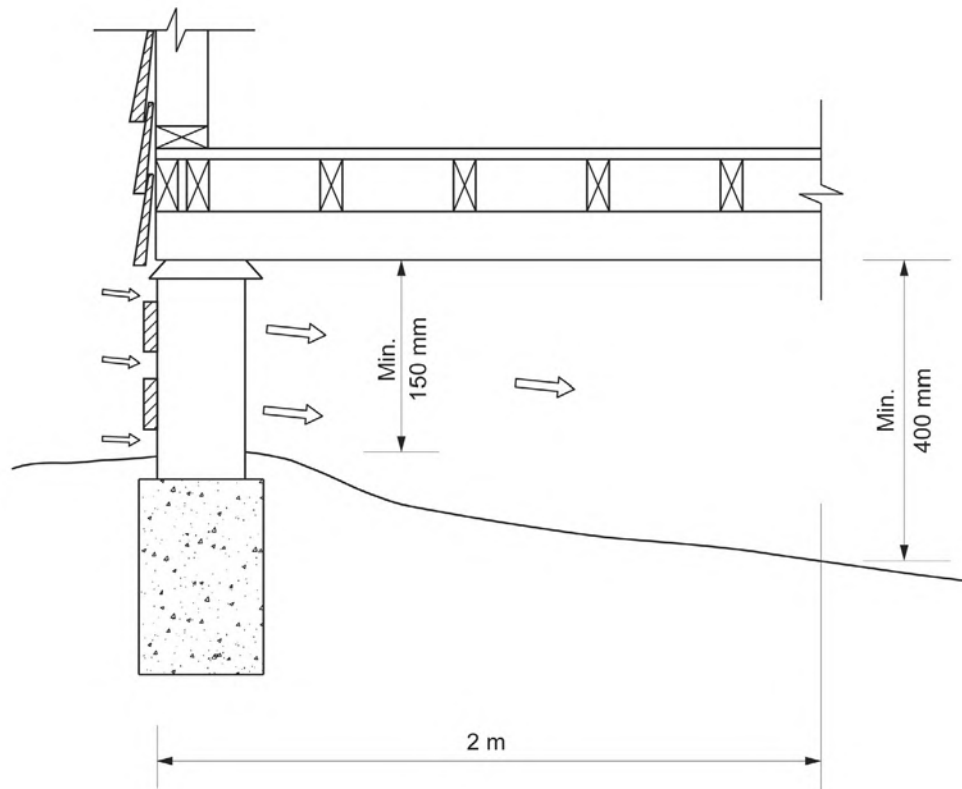

Figure 3.4.3a Subfloor clearance requirements



(see Notes to [Table 3.4.1.1](#) and [Table 3.4.1.2](#))

Figure 3.4.3b Subfloor clearance requirements

**Explanatory information:**

Subfloor ventilation is cross ventilation of the subfloor space between the underside of the subfloor and the ground surface under a building.

Ground moisture rising into or entering the subfloor space can create a damp environment which encourages timber rot, fungus growth and the potential for termite activity. Subfloor ventilation increases air flow, reducing any damaging water vapour in the subfloor space.

Factors that can affect achieving satisfactory levels of subfloor ventilation include height above ground, prevailing breezes (air transfer), differential temperature and humidity between the subfloor and the external environment and good building practice.

The amount of subfloor ventilation *required* for a building is related to the relative humidity likely to be encountered in that location.

Figure 3.4.1 shows three broad climatic zones based on the prevailing relative humidity and includes a description of the relative humidity conditions which define each zone. If reliable weather data is available, these descriptions may be useful in determining which zone a particular location is in.

The zones shown in Figure 3.4.1 were determined by analysis of the average relative humidity at 9 am and 3 pm in January and July. The season with the highest relative humidity is used. Generally this will be July for southern Australia and January for northern Australia.

Table 3.4.1.1 and Table 3.4.1.2 specify the minimum amount of subfloor ventilation openings and height of subfloor framing members above ground level for the three climatic zones illustrated in Figure 3.4.1. The table allows subfloor ventilation rates to be halved if the ground within the subfloor space is sealed by an impervious membrane because humidity levels in the space will not be affected by moisture from the soil.

Part 3.4.2 Steel framing

Appropriate *Performance Requirements*

Where an alternative steel framing system is proposed as a *Performance Solution* to that described in [Part 3.4.2](#), that proposal must comply with—

- (a) *Performance Requirement P2.1.1*; and
- (b) the relevant *Performance Requirements* determined in accordance with [A2.2\(3\)](#) and [A2.4\(3\)](#) as applicable.

Acceptable Construction Manuals

3.4.2.0 Application

[Performance Requirement P2.1.1](#) is satisfied for steel framing if it is designed and constructed in accordance with one of the following:

- (a) Residential and low-rise steel framing:
 - (i) Design: NASH Standard 'Residential and Low-Rise Steel Framing' Part 1.
 - (ii) Design solutions: NASH Standard 'Residential and Low-Rise Steel Framing' Part 2.
- (b) Steel structures: AS 4100.
- (c) Cold-formed steel structures: AS/NZS 4600.

Explanatory information:

Design requirements for other materials used in combination with steel framing, including the use of concrete floors, structural steel support beams, etc. are described in [Part 3.0](#) — Structural provisions or [Part 3.4.4](#) for structural steel members.

Part 3.4.3 Timber framing

Appropriate *Performance Requirements*

Where an alternative timber framing design is proposed as a *Performance Solution* to that described in [Part 3.4.3](#), that proposal must comply with—

- (a) *Performance Requirement P2.1.1*; and
- (b) the relevant *Performance Requirements* determined in accordance with [A2.2\(3\)](#) and [A2.4\(3\)](#) as applicable.

Acceptable Construction Manuals

3.4.3.0

Performance Requirement P2.1.1 is satisfied for a timber frame if it is designed and constructed in accordance with the following, as appropriate:

- (a) Design of timber structures: AS 1720.1.
- (b) Design of nailplated timber roof trusses: AS 1720.5.
- (c) Residential timber-framed construction – non-cyclonic areas: AS 1684.2.
- (d) Residential timber-framed construction – cyclonic areas: AS 1684.3.
- (e) Residential timber-framed construction – non-cyclonic areas (simplified): AS 1684.4.
- (f) Installation of particleboard flooring: AS 1860.2.

State and Territory Variations

In Queensland after 3.4.3.0(f) insert Qld 3.4.3.0(g) as follows:

Qld 3.4.3.0(g) Timber Species

- (g) Timber Species

In addition to sub-clauses (a) to (f) above, timber used for structural purposes must be a species scheduled for the appropriate use in Schedules A, B or C of Book 2 of the December 2017 version of the “Queensland Government, Department of Agriculture, Fisheries and Forestry - Construction timbers in Queensland, Book 1 and Book 2: Properties and specifications for satisfactory performance of construction timbers in Queensland - Class 1 and 10 buildings (Houses, carports, garages, greenhouses and sheds)”.

Explanatory information:

1. Design requirements for other materials used in combination with timber framing, including the use of concrete floors, structural steel support beams, etc. are described in [Part 3.0](#) — Structural provisions or [Part 3.4.4](#) — Structural steel members.
2. The weight of roof or ceiling insulation, particularly if additional ceiling insulation is used for compliance with the energy efficiency provisions, needs to be considered in the selection of plasterboard, plasterboard fixings and building framing.

Part 3.4.4 Structural steel members

Appropriate Performance Requirements

Where an alternative structural steel member system is proposed as a *Performance Solution* to that described in Part 3.4.4, that proposal must comply with—

- (a) *Performance Requirement P2.1.1*; and
- (b) the relevant *Performance Requirements* determined in accordance with A2.2(3) and A2.4(3) as applicable.

Explanation of Terms

3.4.4

The following described terms are used in this Part:

Figure 3.4.4.0a Effective member spacing for structural steel bearers and strutting beams—Single spanning rafter or joist

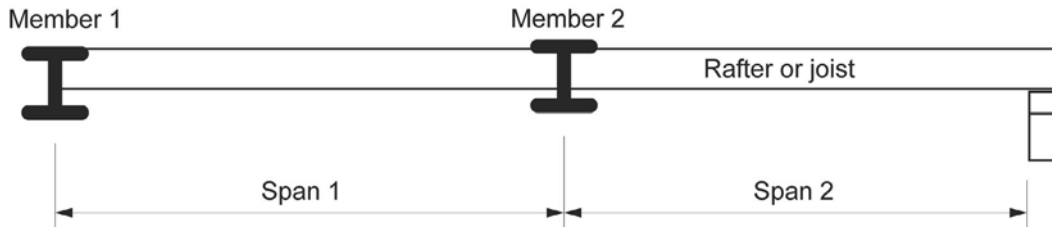

Table 3.4.4.0a Effective member spacing for structural steel bearers and strutting beams—Single spanning rafter or joist

Design member	Member 1	Member 2
Effective member spacing	$0.5 \times \text{Span 1}$	$0.5 \times (\text{Span 1} + \text{Span 2})$

Figure 3.4.4.0b Effective member spacing for structural steel bearers and strutting beams—Continuous spanning rafter or joist

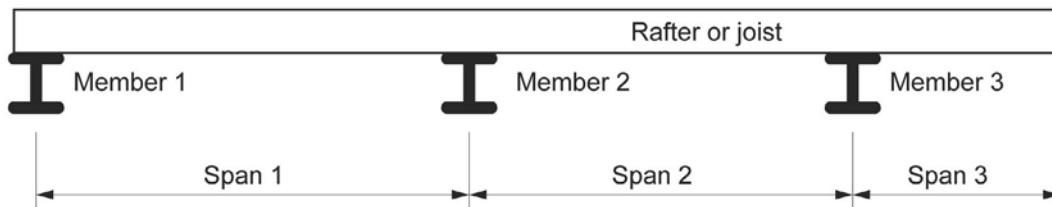

Table 3.4.4.0b Effective member spacing for structural steel bearers and strutting beams—Continuous spanning rafter or joist

Design Member	Member 1	Member 2	Member 3
Effective member spacing	$0.4 \times \text{Span 1}$	$0.6 \times (\text{Span 1} + \text{Span 2})$	$0.5 \times (\text{Span 2}) + \text{Span 3}$

Steel member abbreviations are as follows:

TFB — tapered flange beam.

UB — universal beam.

RHS — rectangular hollow section.

Framing

- PFC** — parallel flange channel.
TFC — tapered flange channel.
EA — equal angle.
UA — unequal angle.
SHS — square hollow section.
CHS — circular hollow section.

Acceptable Construction Manuals

3.4.4.0 Application

Performance Requirement P2.1.1 is satisfied for structural steel sections if they are designed and constructed in accordance with one of the following:

- (a) Steel structures: AS 4100.
- (b) Cold-formed steel structures: AS/NZS 4600.

Explanatory information:

Design requirements for other materials used in combination with structural steel members are described in [Part 3.4.2](#) — Steel framing, [3.4.3](#) — Timber framing or [Part 3.0](#) — Structural provisions.

Acceptable Construction Practice

3.4.4.1 Application

- (a) Compliance with this acceptable construction practice satisfies [P2.1.1](#) in respect to structural stability, provided—
 - (i) the building is located in an area with a *design wind speed* of not more than N3; and

Explanatory information:

- (a) Information on *design wind speeds* for particular areas may be available from the *appropriate authority*.
- (b) A map indicating cyclonic regions of Australia is contained in [Part 3.0](#).
 - (ii) the first dimension of steel sections is installed vertically; and
 - (iii) all loads are uniformly distributed (unless otherwise noted or allowed for); and
 - (iv) the building is one for which Appendix A of AS 1170.4 contains no specific earthquake design requirements; and

Explanatory information:

There are certain limitations on the application to domestic structures such as Class 1a and 1b buildings in Appendix A of AS 1170.4. These limitations include building height, roof slope, etc. For additional information refer to Appendix A of AS 1170.4.

- (v) the structural steel member is not subject to snow loads.
- (b) Compliance with [3.4.4.4](#) satisfies [P2.1.1](#) in respect to corrosion protection requirements.

3.4.4.2 Structural steel members

- (a) Structural steel members may be used as follows:
 - (i) Bearers supporting a timber floor or non-*loadbearing* stud wall — in accordance with [Figure 3.4.4.1](#), [Table 3.4.4.1a](#) and [Table 3.4.4.1b](#).
 - (ii) Strutting beams supporting roof and ceiling loads — in accordance with [Figure 3.4.4.2](#) and [Table 3.4.4.2a](#) to [Table 3.4.4.2b](#).
 - (iii) Lintels supporting roof, ceiling, frame and timber floor — in accordance with [Figure 3.4.4.3](#) and [Table 3.4.4.3a](#) to [Table 3.4.4.3b](#).
 - (iv) Columns — in accordance with [3.4.4.3](#).

Framing

- (b) Structural steel members described in this Part must be protected against corrosion in accordance with 3.4.4.4.
- (c) Joists, bearers and lintels must be restrained from lateral movement or twisting along their length by fixing rafters or joists to the top flange of the member so that it prevents that member from moving laterally.
- (d) End supports for joists, bearers and lintels must transfer loads to the footings and have a bearing distance as follows:
- For single spans, the bearing distance must not be less than the width of the member.
 - For continuous spans, internal bearing must be not less than two times the width of the member.

Figure 3.4.4.1 Bearer supporting a timber floor and non-loadbearing stud wall

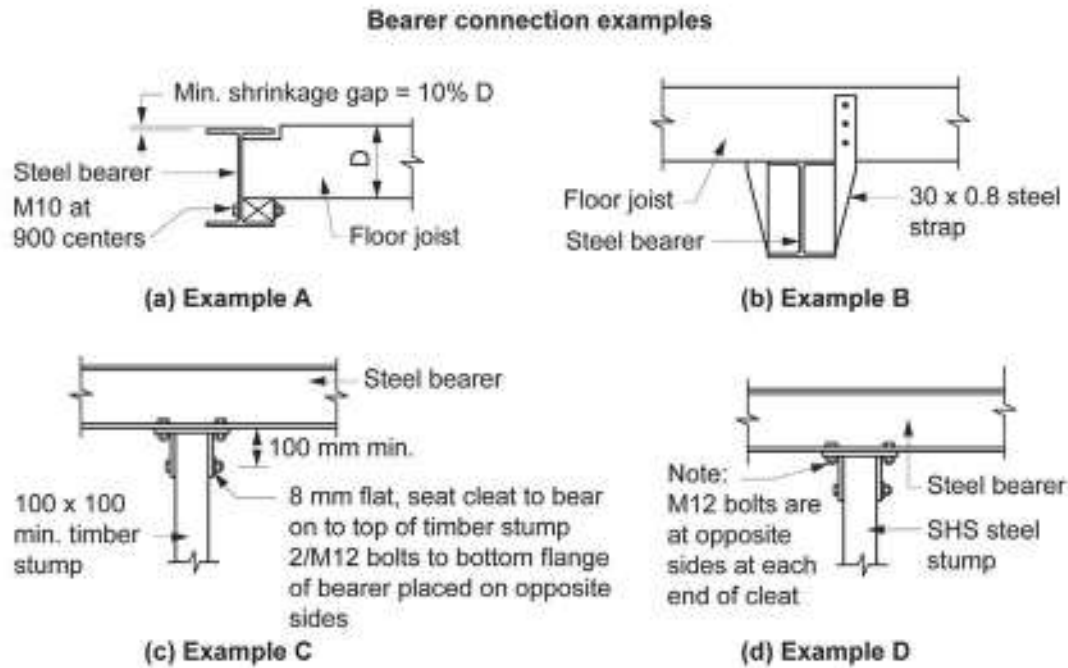

Table 3.4.4.1a Maximum acceptable bearer span (single span) - bearers supporting a timber floor and non-load-bearing stud wall

Steel Section	1.8 EBS	2.4 EBS	3.0 EBS	3.6 EBS	4.2 EBS
125TFB	4.1 m	3.8 m	3.6 m	3.4 m	3.2 m
180UB16.1	5.1 m	4.7 m	4.5 m	4.3 m	4.1 m
200UB18.2	5.6 m	5.2 m	5.0 m	4.7 m	4.6 m
250UB25.7	6.8 m	6.4 m	6.0 m	5.8 m	5.6 m
250x150x9.0 RHS	7.7 m	7.1 m	6.7 m	6.4 m	6.2 m
250x150x5.0 RHS	6.8 m	6.3 m	5.9 m	5.7 m	5.5 m
310UB32.0	7.9 m	7.3 m	7.0 m	6.7 m	6.4 m
125x75x2.0 RHS	3.1 m	2.8 m	2.6 m	2.5 m	2.4 m
125x75x3.0 RHS	3.5 m	3.2 m	3.0 m	2.8 m	2.7 m
150x50x2.0 RHS	3.4 m	3.1 m	2.8 m	2.7 m	2.5 m
150x50x3.0 RHS	3.7 m	3.4 m	3.2 m	3.0 m	2.9 m
100TFC	3.2 m	2.9 m	2.7 m	2.6 m	2.4 m
150PFC	4.8 m	4.5 m	4.2 m	4.0 m	3.9 m
180PFC	5.4 m	5.1 m	4.8 m	4.6 m	4.4 m
200PFC	5.9 m	5.5 m	5.2 m	5.0 m	4.8 m
250PFC	7.2 m	6.7 m	6.4 m	6.1 m	5.9 m
300PFC	8.1 m	7.6 m	7.2 m	6.9 m	6.6 m

Notes to Table 3.4.4.1a:

Framing

1. EBS = Effective bearer spacing (m).
2. Steel is base grade.
3. Load must be evenly distributed along the member.
4. See 3.4.2.3 for provisions that apply to suspended floors in single-storey and ground floor construction of suspended steel floor frames.
5. Effective bearer spacing is a measure of the width of the load area being supported by the member (for single span members see Table 3.4.4.0a and Figure 3.4.4.0a).

Table 3.4.4.1b Maximum acceptable bearer span (continuous span) - bearers supporting a timber floor and non-loadbearing stud wall

Steel Section	1.8 EBS	2.4 EBS	3.0 EBS	3.6 EBS	4.2 EBS
125TFB	4.7 m	4.3 m	3.8 m	3.5 m	3.2 m
180UB16.1	5.9 m	5.5 m	5.2 m	5.0 m	4.7 m
200UB18.2	6.5 m	6.0 m	5.7 m	5.5 m	5.3 m
250UB25.7	7.9 m	7.4 m	7.0 m	6.7 m	6.4 m
250x150x9.0 RHS	8.8 m	8.2 m	7.8 m	7 m	7.1 m
250x150x5.0 RHS	7.8 m	7.2 m	6.8 m	6.5 m	6.3 m
310UB32.0	9.1 m	8.5 m	8.1 m	7.7 m	7.4 m
125x75x2.0 RHS	4.0 m	3.7 m	3.5 m	3.3 m	3.1 m
125X75X3.0 RHS	4.4 m	4.1 m	3.9 m	3.7 m	3.5 m
150x50x2.0 RHS	4.2 m	3.9 m	3.7 m	3.5 m	3.4 m
150x50x3.0 RHS	4.6 m	4.3 m	4.1 m	3.9 m	3.7 m
100TFC	3.7 m	3.2 m	2.8 m	2.6 m	2.4 m
150PFC	5.5 m	5.1 m	4.9 m	4.7 m	4.5 m
180PFC	6.3 m	5.9 m	5.6 m	5.3 m	5.1 m
200PFC	6.8 m	6.3 m	6.0 m	5.7 m	5.5 m
250PFC	8.4 m	7.8 m	7.4 m	7.1 m	6.8 m
300PFC	9.4 m	8.8 m	8.3 m	8.0 m	7.7 m

Notes to Table 3.4.4.1b:

1. EBS = Effective bearer spacing (m).
2. Steel is base grade.
3. Load must be evenly distributed along the member.
4. For continuous floor bearers, the variation in span length should not be more than 10%.
5. See 3.4.2.3 for provisions that apply to suspended floors in single-storey and ground floor construction of suspended steel floor frames.
6. Effective bearer spacing is a measure of the width of the load area being supported by the member (for continuous span members see Table 3.4.4.0b and Figure 3.4.4.0b).

Framing

Figure 3.4.4.2 Strutting beam supporting a roof and ceiling

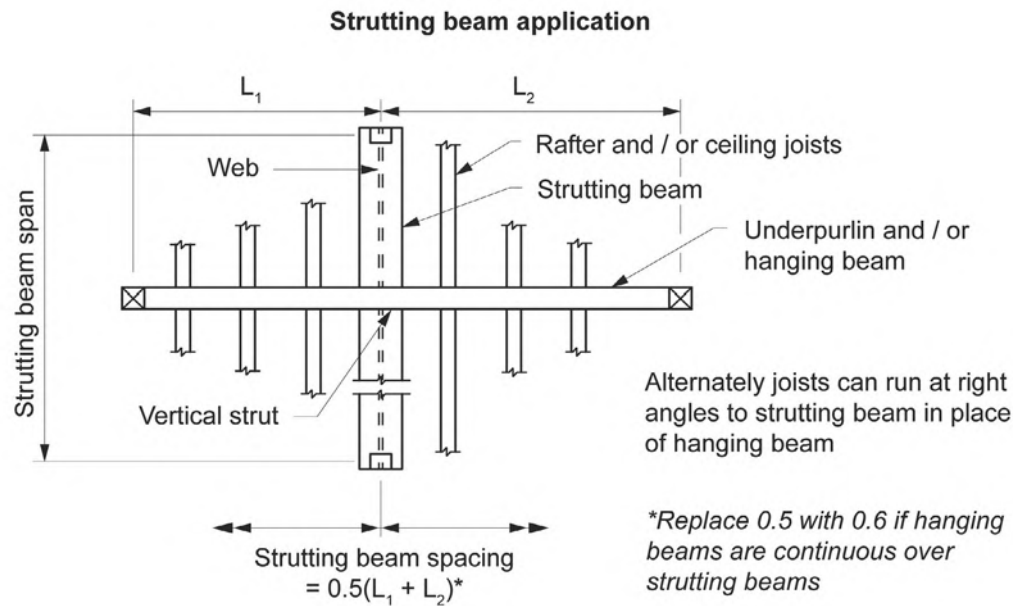

Table 3.4.4.2a Maximum acceptable strutting beam span (steel sheet roof) - strutting beam supporting a roof and ceiling

Steel Section	1.8 SBS	2.4 SBS	3.0 SBS	3.6 SBS	4.2 SBS
125TFB	5.7 m	5.4 m	5.1 m	4.9 m	4.6 m
150UB14.0	6.4 m	6.0 m	5.7 m	5.4 m	5.1 m
200UB18.2	7.9 m	7.4 m	7.1 m	6.8 m	6.5 m
250UB31.4	10.0 m	9.4 m	9.0 m	8.7 m	8.4 m
310UB46.2	11.9 m	11.3 m	10.8 m	10.5 m	10.1 m
100TFC	4.6 m	4.4 m	4.2 m	3.9 m	3.7 m
150PFC	6.7 m	6.3 m	6.0 m	5.8 m	5.6 m
200PFC	8.2 m	7.7 m	7.4 m	7.1 m	6.8 m
250PFC	10.0 m	9.4 m	9.0 m	8.7 m	8.4 m
300PFC	11.1 m	10.5 m	10.1 m	9.7 m	9.4 m

Notes to Table 3.4.4.2a:

1. SBS = Strutting beam spacing (m).
2. If point load applied, then it must be located within the middle third of the strutting beam span.
3. Top and bottom flanges of strutting beam must be laterally restrained at the loading point.
4. Strutting beam must be tied down at the support point, in the case of steel sheet roofs.
5. Steel is base grade.

Table 3.4.4.2b Maximum acceptable strutting beam span (tiled roof) - strutting beam supporting a roof and ceiling

Steel Section	1.8 SBS	2.4 SBS	3.0 SBS	3.6 SBS	4.2 SBS
125TFB	4.9 m	4.6 m	4.4 m	4.2 m	4.1 m
150UB14.0	5.5 m	5.2 m	4.9 m	4.7 m	4.5 m
200UB18.2	6.9 m	6.4 m	6.1 m	5.8 m	5.6 m
250UB31.4	8.8 m	8.2 m	7.8 m	7.5 m	7.2 m
310UB46.2	10.6 m	10.0 m	9.5 m	9.1 m	8.8 m
100TFC	4.0 m	3.7 m	3.6 m	3.4 m	3.2 m

Framing

Steel Section	1.8 SBS	2.4 SBS	3.0 SBS	3.6 SBS	4.2 SBS
150PFC	5.8 m	5.5 m	5.2 m	5.0 m	4.8 m
200PFC	7.2 m	6.7 m	6.4 m	6.1 m	5.9 m
250PFC	8.8 m	8.2 m	7.8 m	7.5 m	7.3 m
300PFC	9.8 m	9.3 m	8.8 m	8.4 m	8.2 m

Notes to Table 3.4.4.2b:

1. SBS = Strutting beam spacing (m).
2. If point load applied, then it must be located within the middle third of the strutting beam span.
3. Top and bottom flanges of strutting beam must be laterally restrained at the loading point.
4. Steel is base grade.

Figure 3.4.4.3 Lintels supporting roof, frames and timber floors

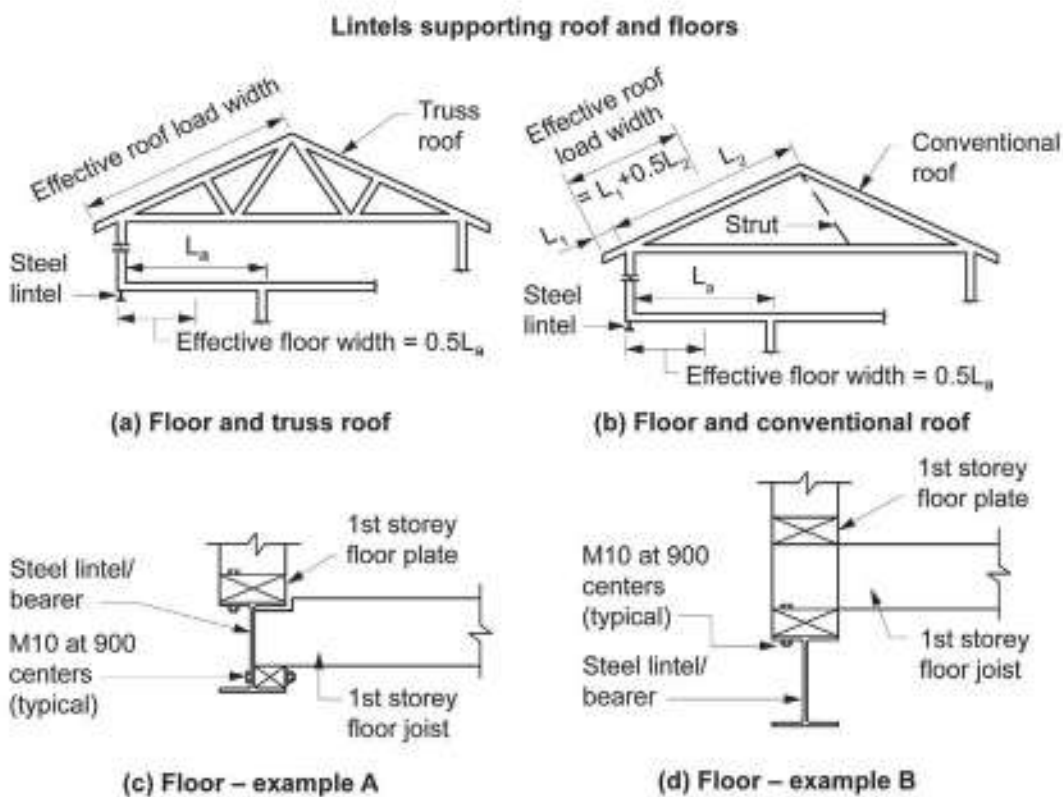

Table 3.4.4.3a Maximum acceptable lintel span (steel sheet roof) - lintel supporting roof, frames and timber floors (m)

Steel Section	1.8 ELW	2.4 ELW	3.0 ELW	3.6 ELW	4.2 ELW
125TFB	3.7 m	3.4 m	3.2 m	3.0 m	2.8 m
150UB14.0	4.1 m	3.9 m	3.7 m	3.5 m	3.3 m
200UB25.4	5.6 m	5.3 m	5.0 m	4.8 m	4.7 m
250UB31.4	6.6 m	6.2 m	5.9 m	5.7 m	5.5 m
100TFC	2.8 m	2.6 m	2.4 m	2.3 m	2.1 m
150PFC	4.4 m	4.1 m	3.9 m	3.7 m	3.6 m
200PFC	5.4 m	5.0 m	4.8 m	4.6 m	4.4 m
250PFC	6.6 m	6.2 m	5.9 m	5.7 m	5.5 m
75X75X5EA	1.3 m	1.2 m	1.1 m	N/A	N/A
90X90X6EA	1.9 m	1.6 m	1.5 m	1.3 m	1.2 m

Framing

Steel Section	1.8 ELW	2.4 ELW	3.0 ELW	3.6 ELW	4.2 ELW
100X100X6EA	2.0 m	1.8 m	1.6 m	1.5 m	1.4 m
125X75X6UA	2.3 m	2.0 m	1.8 m	1.7 m	1.5 m
150X100X10UA	3.9 m	3.6 m	3.2 m	2.9 m	2.7 m

Notes to Table 3.4.4.3a:

1. ELW = Effective load width (m).
2. Top flange of lintel must be laterally restrained at the loading points.
3. Load must be evenly distributed along the member (e.g. joists).
4. Angle lintels - first dimension corresponds to vertical leg (e.g. 100x75x6UA, 100 mm leg is vertical).
5. For lintels supporting masonry walls, see [Part 3.3.3](#).

Table 3.4.4.3b Maximum acceptable lintel span (tiled roof)—lintel supporting roof, frames and timber floors

Steel Section	1.8 ELW	2.4 ELW	3.0 ELW	3.6 ELW	4.2 ELW
125TFB	3.6 m	3.3 m	3.0 m	2.9 m	2.7 m
150UB14.0	4.0 m	3.7 m	3.5 m	3.3 m	3.2 m
200UB25.4	5.4 m	5.1 m	4.8 m	4.6 m	4.5 m
250UB31.4	6.3 m	6.0 m	5.7 m	5.4 m	5.2 m
100TFC	2.7 m	2.5 m	2.3 m	2.1 m	2.0 m
150PFC	4.2 m	3.9 m	3.7 m	3.6 m	3.4 m
200PFC	5.1 m	4.8 m	4.6 m	4.4 m	4.2 m
250PFC	6.3 m	6.0 m	5.7 m	5.4 m	5.3 m
75X75X5EA	1.3 m	1.1 m	N/A	N/A	N/A
90X90X6EA	1.7 m	1.5 m	1.4 m	1.3 m	1.2 m
100X100X6EA	1.9 m	1.7 m	1.5 m	1.4 m	1.3 m
125X75X6UA	2.2 m	1.9 m	1.7 m	1.6 m	1.4 m
150X100X10UA	3.7 m	3.3 m	3.0 m	2.8 m	2.6 m

Notes to Table 3.4.4.3b:

1. ELW = Effective load width (m).
2. Top flange of lintel must be laterally restrained at the loading points.
3. Load must be evenly distributed along the member (e.g. joists).
4. Angle lintels - first dimension corresponds to vertical leg (e.g. 100x7 x6UA, 100 mm leg is vertical).
5. For lintels supporting masonry walls, see [Part 3.3.3](#).

3.4.4.3 Columns

Columns may support the area provided for in [Table 3.4.4.6a](#) to [Table 3.4.4.6b](#) provided—

- (a) the effective height of the column is determined in accordance with [Figure 3.4.4.4](#) and [Table 3.4.4.4](#); and
- (b) the floor area to be supported is determined in accordance with [Figure 3.4.4.5](#) and [Table 3.4.4.5](#); and
- (c) the load eccentricity between the centre of the column and the applied vertical loading complies with [Figure 3.4.4.6](#).

Framing

Figure 3.4.4.4 Determining effective column height—Column height (H)

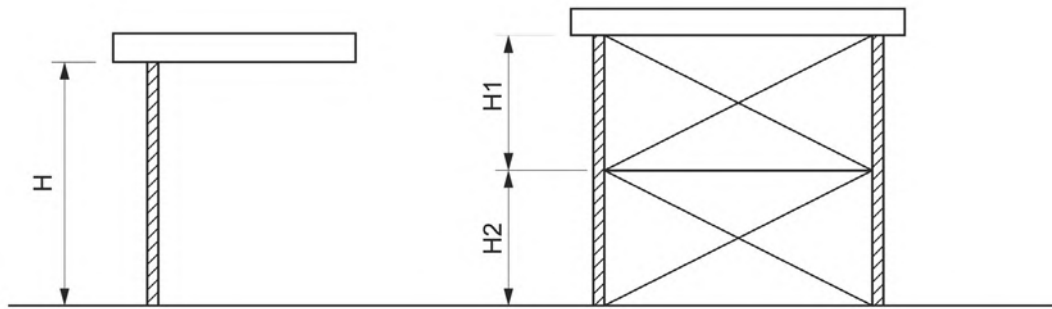

Table 3.4.4.4 Determining effective column height—column height factor (F1)

Base detail	Fully braced ⁽¹⁾ construction	Unbraced construction (cantilever columns) ⁽²⁾
Cast into footing	1.00	2.60
Fixed by bolts to footing or slab	1.20	must not be used
Fixed by intermediate floor or bracing in both directions	1:20	2.60

Notes to Table 3.4.4.4:

1. To determine the column effective height, the actual column height (H) in Figure 3.4.4.4 must be multiplied by a column height factor (F1) in Table 3.4.4.4.
2. H = Distance measured from the top of footing to underside of supported beam or bearer, or between intermediate lateral bracing points.
3. The flooring system must be fully braced to footing level by—
 - a. a combination of column bracing sets, and timber or masonry bracing walls; or
 - b. the provision of cantilever steel columns only (i.e. no column bracing sets, timber or masonry bracing walls).

Framing

Figure 3.4.4.5 Determining floor area supported by columns

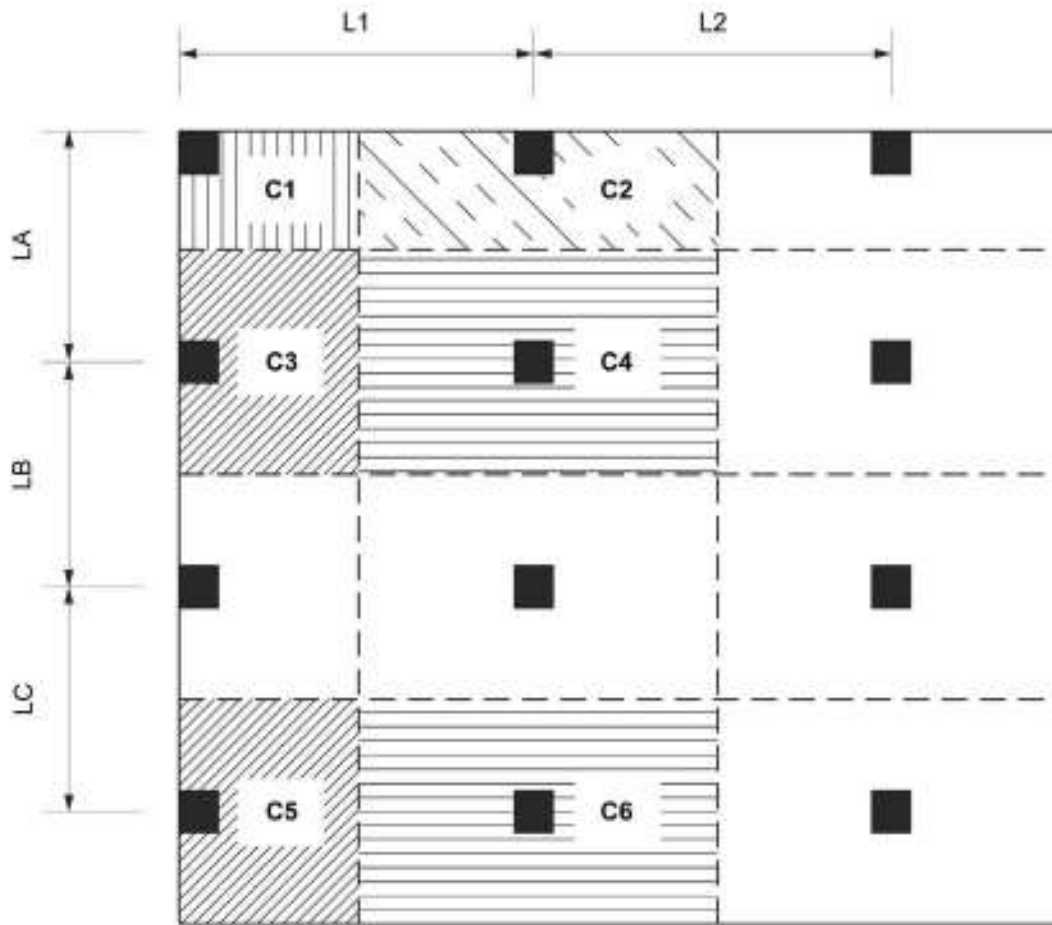

Table 3.4.4.5 Area supported by columns

Column descriptor (as shown in Figure 3.4.4.5)	Total area supported
C1	$0.375L1 \times 0.375LA$
C2	$0.625(L1 + L2) \times 0.375LA$
C3	$0.375L1 \times 0.625(LA + LB)$
C4	$0.625(L1 + L2) \times 0.625(LA + LB)$
C5	$0.375L1 \times (L \text{ cant} + 0.5LC)$
C6	$0.625(L1 + L2) \times (L \text{ cant} + 0.5LC)$

Note to Table 3.4.4.5: The total area supported depends on the position of the column in the structure as shown in Figure 3.4.4.5. To calculate the correct area supported by a column, match the column's position with those shown in Figure 3.4.4.5, which shows a plan view of a floor and then calculate the total area supported from Table 3.4.4.5.

Framing

Figure 3.4.4.6 Acceptable load eccentricity for columns

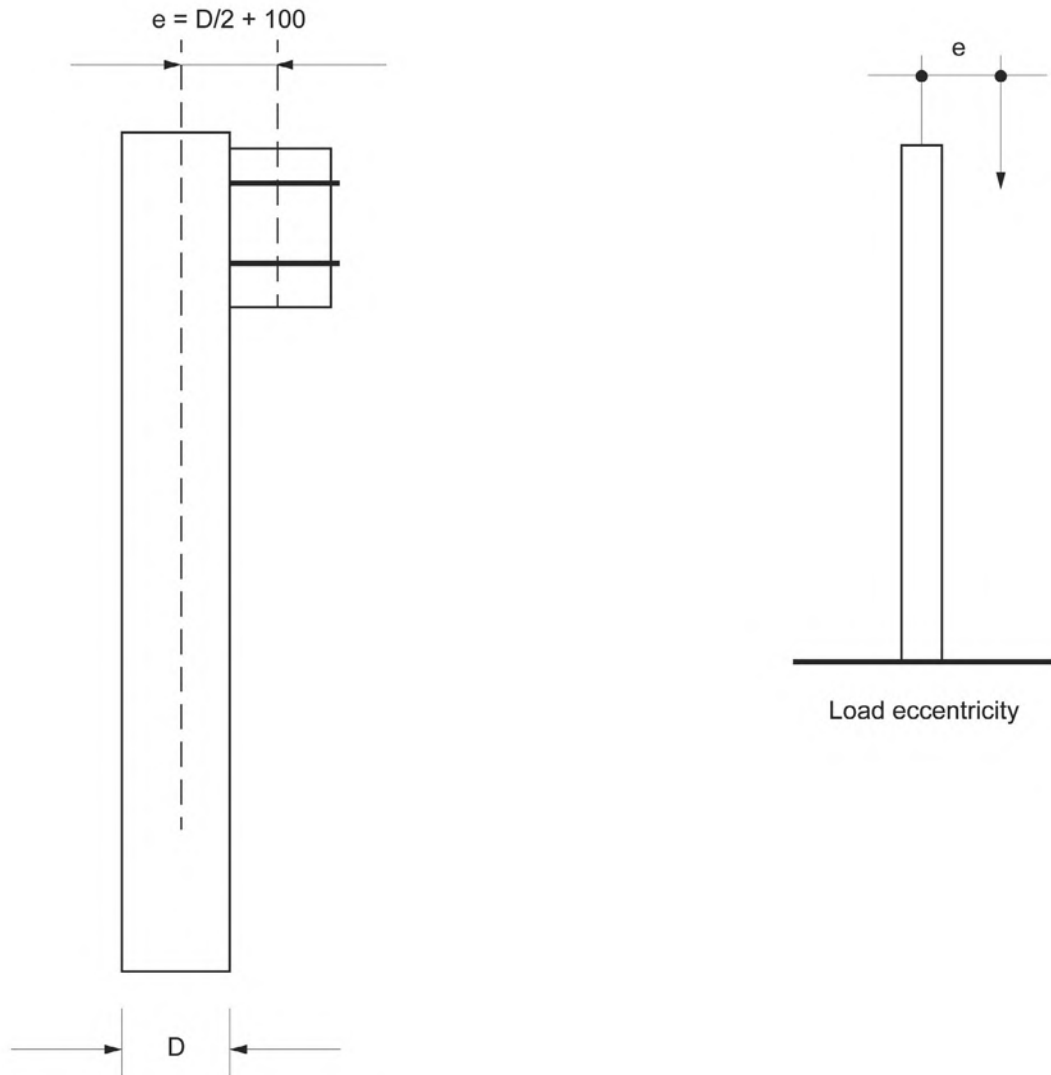

Table 3.4.4.6a Columns—supporting timber floor only

Column section	Column effective height (mm)	Floor area supported:	Floor area supported:	Floor area supported:	Floor area supported:	Floor area supported:
		5 m ²	10 m ²	15 m ²	20 m ²	25 m ²
CHS C250	600	60.3 x 3.6	88.9 x 4.0	101.6 x 5.0	114.3 x 5.4	139.7 x 5.0
CHS C250	1200	60.3 x 4.5	88.9 x 4.0	101.6 x 5.0	114.3 x 5.4	139.7 x 5.0
CHS C250	1800	60.3 x 4.5	88.9 x 4.0	101.6 x 5.0	114.3 x 5.4	139.7 x 5.0
CHS C250	2400	60.3 x 4.5	88.9 x 4.0	101.6 x 5.0	114.3 x 5.4	139.7 x 5.0
CHS C250	3600	76.1 x 3.6	101.6 x 4.0	114.3 x 4.5	139.7 x 5.4	139.7 x 5.0
CHS 350	600	60.3 x 2.9	88.9 x 2.6	101.6 x 3.2	114.3 x 3.6	139.7 x 3.5
CHS 350	1200	60.3 x 2.9	88.9 x 2.6	101.6 x 3.2	114.3 x 3.6	139.7 x 3.5
CHS 350	1800	60.3 x 2.9	101.6 x 2.6	114.3 x 3.2	114.3 x 3.6	139.7 x 3.5
CHS 350	2400	76.1 x 2.3	101.6 x 2.6	114.3 x 3.2	139.7 x 3.0	139.7 x 3.5
CHS 350	3600	88.9 x 2.6	101.6 x 2.6	114.3 x 3.2	139.7 x 3.0	165.1 x 3.0
SHS 350	600	50 x 50 x 2.5	75 x 75 x 2.5	75 x 75 x 4.0	100 x 100 x 4.0	100 x 100 x 4.0
SHS 350	1200	65 x 65 x 2.0	75 x 75 x 2.5	75 x 75 x 4.0	100 x 100 x 4.0	100 x 100 x 4.0
SHS 350	1800	65 x 65 x 2.0	75 x 75 x 3.0	100 x 100 x 3.0	100 x 100 x 4.0	100 x 100 x 4.0

Framing

Column section	Column effective height (mm)	Floor area supported:	Floor area supported:	Floor area supported:	Floor area supported:	Floor area supported:
		5 m ²	10 m ²	15 m ²	20 m ²	25 m ²
SHS 350	2400	65 x 65 x 2.0	75 x 75 x 3.0	100 x 100 x 3.0	100 x 100 x 4.0	100 x 100 x 5.0
SHS 350	3600	65 x 65 x 2.5	75 x 75 x 4.0	100 x 100 x 3.0	100 x 100 x 4.0	100 x 100 x 5.0
SHS 450	600	50 x 50 x 2.0	65 x 65 x 2.5	75 x 75 x 3.0	100 x 100 x 2.8	100 x 100 x 3.3
SHS 450	1200	50 x 50 x 2.0	65 x 65 x 2.5	75 x 75 x 3.0	100 x 100 x 3.0	100 x 100 x 3.3
SHS 450	1800	50 x 50 x 2.3	75 x 75 x 2.3	75 x 75 x 3.3	100 x 100 x 3.0	100 x 100 x 3.8
SHS 450	2400	65 x 65 x 2.0	75 x 75 x 2.5	75 x 75 x 3.5	100 x 100 x 3.0	100 x 100 x 3.8
SHS 450	3600	65 x 65 x 2.3	100 x 100 x 2.0	100 x 100 x 2.8	100 x 100 x 3.8	100 x 100 x 4.0

Note to Table 3.4.4.6a: Tabulated values are the column sections to be used.

Table 3.4.4.6b Columns – supporting tile roof only

Column section	Column effective height (mm)	5 m ²	10 m ²	15 m ²	20 m ²	25 m ²
CHS 250	600	60.3 x 3.6	60.3 x 3.6	76.1 x 3.6	76.1 x 4.5	88.9 x 4.0
CHS 250	1200	60.3 x 3.6	60.3 x 3.6	76.1 x 3.6	76.1 x 4.5	101.6 x 4.0
CHS 250	1800	60.3 x 3.6	60.3 x 3.6	76.1 x 3.6	76.1 x 4.5	101.6 x 4.0
CHS 250	2400	60.3 x 3.6	60.3 x 4.5	76.1 x 3.6	88.9 x 4.0	101.6 x 4.0
CHS 250	3600	60.3 x 3.6	76.1 x 3.6	76.1 x 4.5	88.9 x 4.0	101.6 x 4.0
CHS 350	600	60.3 x 2.3	60.3 x 2.3	76.1 x 2.3	88.9 x 2.6	101.6 x 2.6
CHS 350	1200	60.3 x 2.3	60.3 x 2.9	76.1 x 2.3	88.9 x 2.6	101.6 x 2.6
CHS 350	1800	60.3 x 2.3	60.3 x 2.9	88.9 x 2.6	88.9 x 2.6	101.6 x 2.6
CHS 350	2400	60.3 x 2.3	76.1 x 2.3	88.9 x 2.6	88.9 x 2.6	101.6 x 2.6
CHS 350	3600	60.3 x 2.3	76.1 x 2.3	88.9 x 2.6	101.6 x 2.6	101.6 x 2.6
SHS C350	600	50 x 50 x 2.0	50 x 50 x 2.5	65 x 65 x 2.5	75 x 75 x 2.5	75 x 75 x 3.0
SHS C350	1200	50 x 50 x 2.0	50 x 50 x 2.5	65 x 65 x 2.5	75 x 75 x 2.5	75 x 75 x 3.0
SHS C350	1800	50 x 50 x 2.0	65 x 65 x 2.0	65 x 65 x 2.5	75 x 75 x 2.5	75 x 75 x 3.0
SHS C350	2400	50 x 50 x 2.0	65 x 65 x 2.0	65 x 65 x 2.5	75 x 75 x 2.5	75 x 75 x 4.0
SHS C350	3600	50 x 50 x 2.5	65 x 65 x 2.5	75 x 75 x 2.5	75 x 75 x 3.0	75 x 75 x 4.0
SHS C450	600	50 x 50 x 1.6	50 x 50 x 2.0	65 x 65 x 2.0	65 x 65 x 2.3	65 x 65 x 2.8
SHS C450	1200	50 x 50 x 1.6	50 x 50 x 2.0	65 x 65 x 2.0	65 x 65 x 2.3	65 x 65 x 2.8
SHS C450	1800	50 x 50 x 1.6	65 x 65 x 1.6	65 x 65 x 2.0	65 x 65 x 2.5	75 x 75 x 2.5
SHS C450	2400	50 x 50 x 1.6	50 x 50 x 2.5	65 x 65 x 2.3	75 x 75 x 2.3	75 x 75 x 2.8
SHS C450	3600	50 x 50 x 2.0	65 x 65 x 2.0	75 x 75 x 2.3	100 x 100 x 2.0	100 x 100 x 2.3

Note to Table 3.4.4.6b: Tabulated values are the column sections to be used.

3.4.4.4 Corrosion protection

Structural steel members that are not built into a masonry wall must be protected against corrosion in accordance with Table 3.4.4.7.

Table 3.4.4.7 Protective coatings for steelwork

Environment	Location	Minimum protective coating
Moderate Note 1	Internal	No protection <i>required</i> in a permanently dry location Note 8
Moderate Note 1	External	Option 1. 2 coats alkyd primer Option 2. 2 coats alkyd gloss Option 3. Hot dip galvanised 300 g/m ² min

Framing

Environment	Location	Minimum protective coating
		Option 4. Hot dip galvanised 100 g/m ² min plus— (a) 1 coat solvent based vinyl primer; or (b) 1 coat vinyl gloss or alkyd.
Severe Note 2	Internal	Option 1. 2 coats alkyd primer Option 2. 2 coats alkyd gloss
Severe Note 2	External	Option 1. Inorganic zinc primer plus 2 coats vinyl gloss finishing coats Option 2. Hot dip galvanised 300 g/m ² Option 3. Hot dip galvanised 100 g/m ² min plus— (a) 2 coats solvent based vinyl primer; or (b) 2 coats vinyl gloss or alkyd.

Notes to Table 3.4.4.7:

- Moderate = More than 1 km from *breaking surf* or more than 100 m from salt water not subject to *breaking surf* or non-heavy industrial areas.
- Severe = Within 1 km from *breaking surf* or within 100 m of salt water not subject to *breaking surf* or heavy industrial areas.
- Heavy industrial areas means industrial environments around major industrial complexes.
- The outer leaf and *cavity* of an external masonry wall of a building, including walls under open carports are considered to be external environments. A part of an internal leaf of an external masonry wall which is located in the roof space is considered to be in an internal environment.
- Where a paint finish is applied the surface of the steel, work must be hand or power tool cleaned to remove any rust immediately prior to painting.
- All zinc coatings (including inorganic zinc) require a barrier coat to stop conventional domestic enamels from peeling.
- Refer to the paint manufacturer where decorative finishes are required on top of the minimum coating specified in the table for protection of the steel against corrosion.
- Internal locations subject to moisture, such as in close proximity to kitchen or bathroom exhaust fans are not considered to be in a permanently dry location and protection as specified for external locations is *required*.
- For applications outside the scope of this table, seek specialist advice.

Roof and Wall Cladding

- Part 3.5** **Roof cladding, gutters and downpipes and wall cladding**
- Part 3.5.1** **Sheet roofing**
- Part 3.5.2** **Roof tiles and shingles**
- Part 3.5.3** **Gutters and downpipes**
- Part 3.5.4** **Timber and composite wall cladding**
- Part 3.5.5** **Metal wall cladding**

Part 3.5 Roof and Wall Cladding

Part 3.5 Roof cladding, gutters and downpipes and wall cladding

3.5.0.1 Explanation of terms

Part 3.5.1 Sheet roofing

Acceptable Construction Manuals

3.5.1.0 Application

Acceptable Construction Practice

3.5.1.1 Application

3.5.1.2 Corrosion protection and compatibility requirements for roofing

3.5.1.3 Minimum pitches for metal sheet roofing profiles

3.5.1.4 Maximum spans

3.5.1.5 Fixing of metal sheet roofing

3.5.1.6 Installation of roofing sheets

3.5.1.7 Flashings and cappings

3.5.1.8 Water discharge

Part 3.5.2 Roof tiles and shingles

Acceptable Construction Manuals

3.5.2.0 Application

Acceptable Construction Practice

3.5.2.1 Application

3.5.2.2 Fixing of roof tiles and ancillaries

3.5.2.3 Flashing

3.5.2.4 Sarking

3.5.2.5 Anti-ponding device/board

3.5.2.6 Water discharge

Part 3.5.3 Gutters and downpipes

Acceptable Construction Manuals

3.5.3.0 Application

Acceptable Construction Practice

3.5.3.1 Application

3.5.3.2 Materials

3.5.3.3 Selection of guttering

3.5.3.4 Installation of gutters

3.5.3.5 Downpipes — size and installation

Part 3.5.4 Timber and composite wall cladding

Acceptable Construction Manuals

3.5.4.0 Application

Acceptable Construction Practice

3.5.4.1 Application

3.5.4.2 Timber wall cladding

3.5.4.3 Wall cladding boards

3.5.4.4 Sheet wall cladding

3.5.4.5 Eaves and soffit linings

3.5.4.6 Flashings to wall openings

3.5.4.7 Clearance between cladding and ground

3.5.4.8 Parapet cappings

Part 3.5.5 Metal wall cladding

Acceptable Construction Manuals

3.5.5.0 Application

Part 3.5 Roof cladding, gutters and downpipes and wall cladding

Explanatory information:

This Part contains requirements including weatherproofing and structural requirements, for roof and wall systems. Gutter and downpipe requirements are also contained in this Part.

It should be noted that other construction methods may be used to achieve the same results as specified in this Part provided they comply with the appropriate *Performance Requirement*.

3.5.0.1 Explanation of terms

The following diagrams depict relevant roofing and supporting members and associated terminology used to describe them in the *Housing Provisions*.

In most cases the terminology is applicable for both steel and timber frame members.

Figure 3.5.0.1 Section of a typical sheet roof

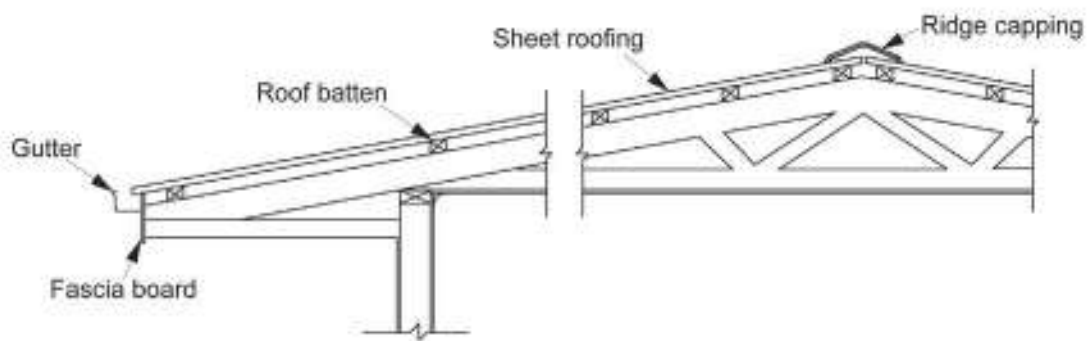
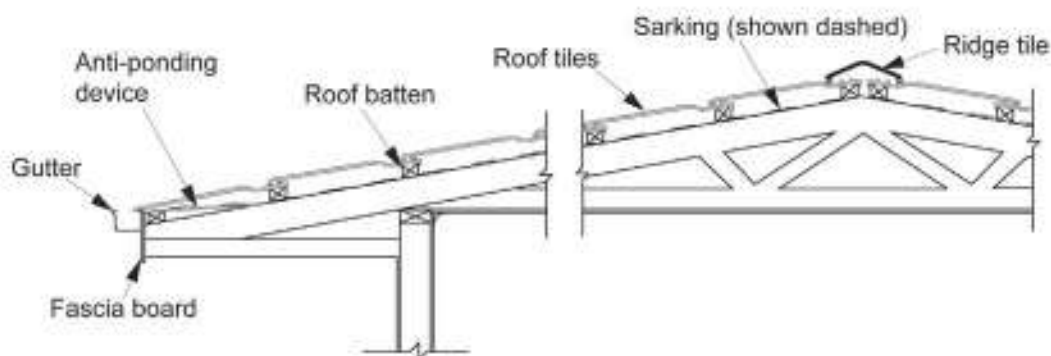

Figure 3.5.0.2 Section of a typical tile roof



Part 3.5.1 Sheet roofing

Appropriate *Performance Requirements*

Where an alternative roof cladding is proposed as a *Performance Solution* to that described in [Part 3.5.1](#), that proposal must comply with—

- (a) *Performance Requirement P2.1.1*; and
- (b) *Performance Requirement P2.2.2*; and
- (c) the relevant *Performance Requirements* determined in accordance with [A2.2\(3\)](#) and [A2.4\(3\)](#) as applicable.

Acceptable Construction Manuals

3.5.1.0 Application

Performance Requirements P2.1.1 and *P2.2.2* are satisfied for sheet roofing if it complies with one or a combination of the following:

- (a) Metal roofing:
 - (i) AS 1562.1; and
 - (ii) In wind regions C and D in accordance with [Figure 3.0.1](#) (cyclonic area), metal roof assemblies, their connections and immediate supporting members must be capable of remaining in position notwithstanding any permanent distortion, fracture or damage that might occur in the sheet or fastenings under the pressure sequences A to G defined in [Table 3.5.1.0](#).

Table 3.5.1.0 Low-High-Low pressure sequence

Sequence	Number of cycles	Load
A	4500	0 to 0.45 Pt
B	600	0 to 0.6 Pt
C	80	0 to 0.8 Pt
D	1	0 to 1.0 Pt
E	80	0 to 0.8 Pt
F	600	0 to 0.6 Pt
G	4500	0 to 0.45 Pt

Notes to [Table 3.5.1.0](#):

1. Pt is the ultimate limit state wind pressure on internal and external surfaces as determined in accordance with AS/NZS 1170.2, modified by an appropriate factor for variability, as determined in accordance with Table B1 of AS/NZS 1170.0.
 2. The rate of load cycling must be less than 3 Hz.
 3. The single load cycle (sequence D) must be held for a maximum of 10 seconds.
- (b) Plastic sheet roofing: AS/NZS 1562.3.

Explanatory information:

The requirements of [3.5.1.0\(a\)\(ii\)](#) must be read in conjunction with the provisions of AS/NZS 1170.2. The ABCB commissioned research to establish a nationally consistent testing regime for metal roof cladding assemblies in cyclonic areas. The results of this research are contained in [3.5.1.0\(a\)\(ii\)](#).

Low cycle fatigue cracking of metal roof cladding elements during tropical cyclones is a complex process where small changes in load, geometry or material properties can significantly affect the fatigue performance of the cladding system (includes immediate supports, fixings and cladding). The consequences of failure of an element can quickly lead to more elements progressively failing. These failed elements become wind driven debris and so pose a threat to people and other structures as potential missiles.

If a system does not successfully resist the fatigue loading sequence in [Table 3.5.1.0](#), it does not comply.

The test section consists of cladding elements, fastenings and immediate supporting members assembled together in

Roof and Wall Cladding

a manner identical to those parts of the particular roof which the test section is intended to replicate.

Acceptable Construction Practice

3.5.1.1 Application

Compliance with this acceptable construction practice satisfies [Performance Requirements P2.1.1](#) and [P2.2.2](#) for metal sheet roofing, provided the building is located in an area with a [design wind speed](#) of not more than N3.

Explanatory information:

1. **Design wind speeds:**

Information on [design wind speeds](#) for particular areas may be available from the [appropriate authority](#). Also see [Table 3](#) for wind classes. A map indicating wind regions of Australia is contained in [Part 3.0](#).

2. **Other relevant Volume Two sheet roof requirements:**

A number of other Parts of Volume Two contain specific requirements relevant to sheet roofing, in addition to the provisions of this Part. They include—

- a. for the sizing and fixing of roof battens —
 - i. [Part 3.4.2](#) for steel battens; and
 - ii. [Part 3.4.3](#) for timber battens; and
- b. [Part 3.7.3](#) for requirements for roofing over a [separating wall](#); and
- c. [Part 3.5.3](#) for requirements for gutters and downpipes.

3.5.1.2 Corrosion protection and compatibility requirements for roofing

- (a) Metal sheet roofing must be protected from corrosion in accordance with [Table 3.5.1.1](#).
- (b) Where different metals are used in a roofing system, including [flashings](#), fasteners, guttering, downpipes, etc., they must be compatible with each other as described in [Tables 3.5.1.2a](#) to [3.5.1.2d](#) and—
 - (i) no lead materials can be used upstream from aluminium/zinc coated materials; and
 - (ii) no lead materials can be used on roofs that form part of a potable (drinking) water catchment area; and
 - (iii) no copper materials can be used upstream from galvanized coated materials.

Explanatory information:

To prevent corrosion due to adverse chemical reaction of materials used, [3.5.1.2\(b\)](#) ensures that the metal roofing and other materials that come in contact with it, i.e. fasteners, [flashings](#) and cappings, etc. are compatible with each other.

Table 3.5.1.1 Acceptable corrosion protection for metal sheet roofing

Environment	Location	Minimum metal coating in accordance with AS 1397: Metallic coated steel	Minimum metal coating in accordance with AS 1397: Metallic and organic coated steel
Low (Mild steel corrosion rate 1.3 to 25 µm/y)	Typically remote inland areas or more than 1 km from sheltered bays	Z450 galvanised or AZ150 aluminium/zinc or AM125 aluminium/zinc/magnesium	Z275 galvanised or AZ150 aluminium/zinc or AM100 aluminium/zinc/magnesium
Medium (Mild steel corrosion rate 25 to 50 µm/y)	Typically more than 1 km from breaking surf or aggressive industrial areas or more than 50 m from sheltered bays	Z450 galvanised or AZ150 aluminium/zinc or AM125 aluminium/zinc/magnesium	Z275 galvanised or AZ150 aluminium/zinc or AM100 aluminium/zinc/magnesium

Roof and Wall Cladding

Environment	Location	Minimum metal coating in accordance with AS 1397: Metallic coated steel	Minimum metal coating in accordance with AS 1397: Metallic and organic coated steel
High (Mild steel corrosion rate 50 to 80 µm/y)	Typically more than 200 m from <i>breaking surf</i> or aggressive industrial areas or within 50 m from sheltered bays.	AZ150 aluminium/zinc or AM125 aluminium/zinc/magnesium	AZ150 aluminium/zinc or AM100 aluminium/zinc/magnesium
Very High (Mild steel corrosion rate 80 to 200 µm/y)	Typically extends from 100 m inland from <i>breaking surf</i> to 200 m inland from <i>breaking surf</i> , or within 200 m of aggressive industrial areas	Not suitable	AZ200 aluminium/zinc or AM150 aluminium/zinc/magnesium
Very High (Mild steel corrosion rate 80 to 200 µm/y)	Typically within 100 m of <i>breaking surf</i>	Not suitable	Not suitable

Notes to Table 3.5.1.1:

- Low — remote inland** includes dry rural areas remote from the coast or sources of pollution. Many areas of Australia beyond at least 50 km from the sea are in this category, including most cities and towns such as Canberra, Ballarat, Toowoomba, Alice Springs and some suburbs of cities on sheltered bays such as Melbourne, Hobart, Brisbane and Adelaide that are more than 1 km from the sea. However each of these have many exceptions which are in more corrosive categories.
- Medium — urban inland, coastal or industrial** typically coastal areas with low salinity around sheltered bays, such as Port Phillip Bay. This extends from about 50 m from the shoreline to a distance of about 1 km inland but seasonally or in semi-sheltered bays extends 3 to 6 km inland. Along ocean front areas with *breaking surf* and significant salt spray, it extends from 1 km inland to about 10 to 50 km depending on wind direction and topography. Much of the metropolitan areas of Wollongong, Sydney, Newcastle, Perth and the Gold Coast are in this category. This can extend to 30 to 70 km inland in South Australia while on some evidence, other southern Australian coastal zones are in this, or a more severe category. This also includes urban and industrial areas with low pollution and for several kilometres around large industries such as steel works and smelters.
- High** typically occurs on the coast around sheltered bays. Category high extends up to 50 m inland from the shoreline. In areas of rough seas and surf it extends from several hundred metres to about 1 km inland. As with other categories the extent depends on wind, wave action and topography. The category will also be found inside industrial plants and can influence a distance of 1.5 km down wind of the plant.
- Very high** is typical of offshore conditions and is found on the beachfront in regions of rough seas and surf beaches. It can extend inland for several hundred metres. It is also found in aggressive industrial areas with a pH of less than 5.
- All locations described in the table contain variations of greater corrosion severity. If significant, this must be addressed by designing for the most severe environment.
- In locations where metallic coatings are not a suitable form of corrosion protection, the roof sheeting must be of a type that has been designed and manufactured for such environments.

Table 3.5.1.2a Acceptability of contact between different roofing materials – Stainless steel accessory or fastener

Cladding material	Atmosphere classification - Medium to very high as per Table 3.5.1.1	Atmosphere classification - Low as per Table 3.5.1.1
Copper and copper alloys	No	Yes
Stainless steel (300 series)	Yes	Yes
Zinc-coated steel and zinc	No	Yes
Zinc/aluminium coated steel	No	Yes
Aluminium/zinc (AZ) and aluminium/zinc/magnesium (AM) coated steel	No	Yes

Roof and Wall Cladding

Cladding material	Atmosphere classification - Medium to very high as per Table 3.5.1.1	Atmosphere classification - Low as per Table 3.5.1.1
Lead	Yes	Yes

Notes to Table 3.5.1.2a:

1. No — means the metal cannot be used in association with the other metal.
2. Yes — means the metal can be used in association with the other metal.

Table 3.5.1.2b Acceptability of contact between different roofing materials – Zinc-coated steel and zinc accessory or fastener

Cladding material	Atmosphere classification - Medium to very high as per Table 3.5.1.1	Atmosphere classification - Low as per Table 3.5.1.1
Copper and copper alloys	No	No
Stainless steel (300 series)	No	No
Zinc-coated steel and zinc	Yes	Yes
Zinc/aluminium coated steel	Yes	Yes
Aluminium/zinc (AZ) and aluminium/zinc/magnesium (AM) coated steel	Yes	Yes
Lead	No	Yes

Notes to Table 3.5.1.2b:

1. No — means the metal cannot be used in association with the other metal.
2. Yes — means the metal can be used in association with the other metal.

Table 3.5.1.2c Acceptability of contact between different roofing materials - Zinc/aluminium coated steel or aluminium/zinc (AZ) and aluminium/zinc/magnesium (AM) coated steel accessory or fastener

Cladding material	Atmosphere classification - Medium to very high as per Table 3.5.1.1	Atmosphere classification - Low as per Table 3.5.1.1
Copper and copper alloys	No	No
Stainless steel (300 series)	No	No
Zinc-coated steel and zinc	Yes	Yes
Zinc/aluminium coated steel	Yes	Yes
Aluminium/zinc (AZ) and aluminium/zinc/magnesium (AM) coated steel	Yes	Yes
Lead	No	No

Notes to Table 3.5.1.2c:

1. No — means the metal cannot be used in association with the other metal.
2. Yes — means the metal can be used in association with the other metal.

Table 3.5.1.2d Acceptability of contact between different roofing materials - Lead accessory or fastener

Cladding material	Accessory or fastener material:	
	Lead	Lead
Copper and copper alloys	No	Yes
Stainless steel (300 series)	No	Yes
Zinc-coated steel and zinc	No	Yes
Zinc/aluminium coated steel	No	No
Aluminium/zinc (AZ) and aluminium/zinc/magnesium (AM) coated steel	No	No
Lead	Yes	Yes

Roof and Wall Cladding

Notes to Table 3.5.1.2d:

1. No — means the metal cannot be used in association with the other metal.
2. Yes — means the metal can be used in association with the other metal.

3.5.1.3 Minimum pitches for metal sheet roofing profiles

Metal sheet roofing must comply with the minimum pitch requirements for the associated roof profile in accordance with Figure 3.5.1.1.

Figure 3.5.1.1 Minimum pitch requirements for metal roofing profiles - Roof slope and pitch drainage capacity

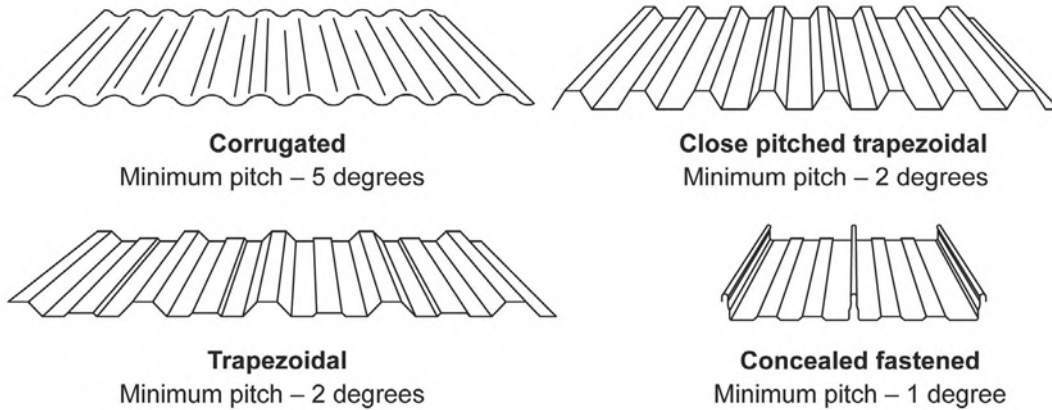

Notes to Figure 3.5.1.1:

1. For minimum end lap requirements see 3.5.1.6(b)(ii).
2. Consideration should be given to the drainage run off capacity of the roof sheeting when determining the minimum pitch and total length of the roof sheet.

3.5.1.4 Maximum spans

Metal sheet roofing must comply with the maximum span limitations between roofing supports in accordance with Table 3.5.1.3 and Figure 3.5.1.2.

Table 3.5.1.3 Maximum roofing spans between supports

Sheet roofing profile	Sheet roofing base metal thickness (mm)	Max. end span (mm) ^{Note 1}	Max. internal span (mm) ^{Note 1}
Corrugated	0.42	900	1200
Close pitched trapezoidal	0.42	1800	2400
Trapezoidal	0.42	1300	1700
Concealed fasteners — narrow sheet	0.42	1750	2100
Concealed fasteners — wide sheet	0.48	1800	2100

Notes to Table 3.5.1.3:

1. Refer to Figure 3.5.1.2 for determination of end span and internal spans.
2. Thermal expansion - Maximum sheet run for pierced fixed metal roofing profiles must be not greater than 25 m when measured between the fasteners at the ends of the sheet.

Figure 3.5.1.2 Maximum spans for roofing between supports

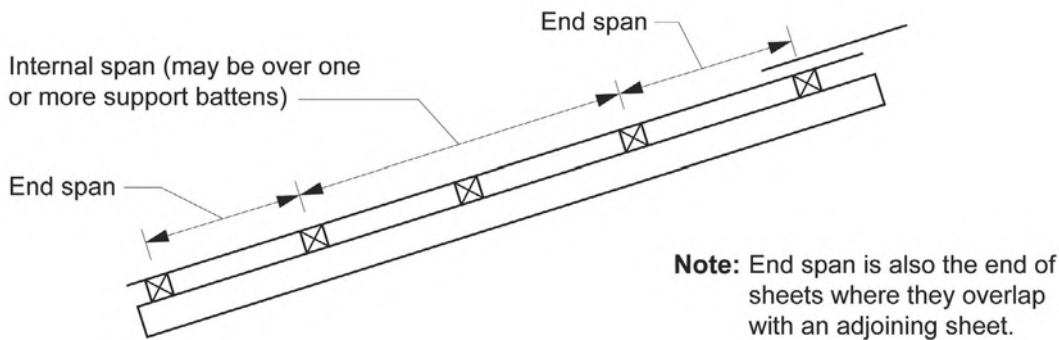

3.5.1.5 Fixing of metal sheet roofing

Metal sheet roofing must—

- (a) be either fixed through the roofing (crest fastening) or have concealed fasteners; and
- (b) be fixed at spacings in accordance with [Table 3.5.1.4](#); and

Table 3.5.1.4 Fixing requirements for sheet roofing

Sheet roofing profile	Fixing: End span	Fixing: Internal spans
Corrugated	Side lap and every second rib	Side lap and every third rib
Close pitched trapezoidal	Side lap and every second rib	Side lap and every third rib
Trapezoidal	Every rib	Every rib
Concealed fasteners	Every rib	Every rib

- (c) use fixings of a compatible metal to the roof in accordance with [Tables 3.5.1.2a to 3.5.1.2d](#); and
- (d) when using both clipped and pierced fastening systems, employ an anti-capillary feature in the side lap of the sheet (see [Figure 3.5.1.3](#)).

Explanatory information:

An anti-capillary feature in the side lap of the sheet is used to prevent capillary action drawing moisture into the lap and to allow the lap to drain. This can also be achieved by not over tightening the sheet fixing. Wherever possible, consideration should be given to laying the metal sheet roofing so that the side lap is facing away from prevailing weather.

Figure 3.5.1.3 Side lap fastening detail

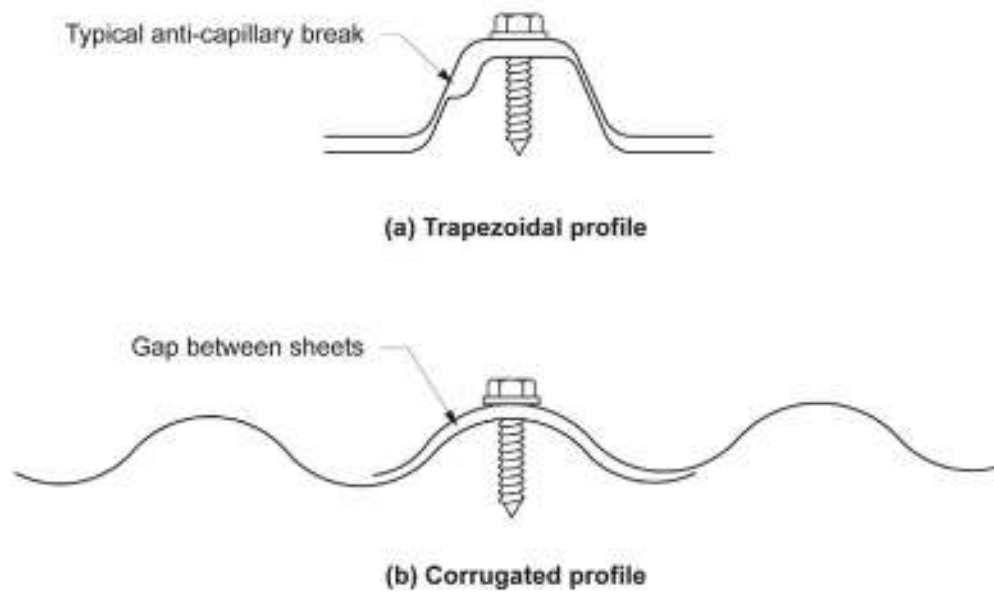

3.5.1.6 Installation of roofing sheets

Sheets must be—

- (a) laid wherever possible using complete lengths from the fascia to ridge; or
- (b) where a complete length cannot be laid—
 - (i) each run must be laid from bottom to top before moving on to the next run (see [Figure 3.5.1.4](#)); and
 - (ii) the minimum end lap must be—
 - (A) for roof slopes above 15 degrees (1:4) – 150 mm; and
 - (B) for roof slopes between 5–15 degrees (1:12-1:4) – 200 mm; and
- (c) stop ended (i.e. each valley turned up 60 degrees) at the ridge line of each length.

Figure 3.5.1.4 Sheet laying sequence

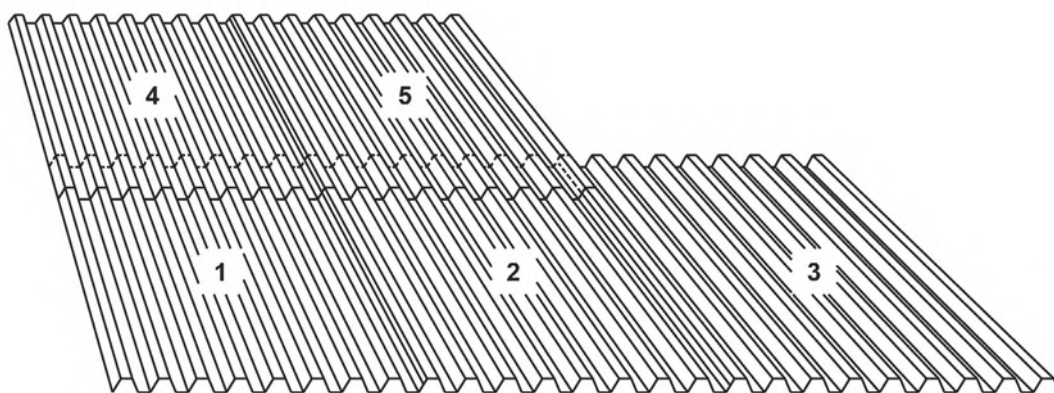

3.5.1.7 Flashings and cappings

- (a) Sheet metal roof *flashings* and cappings must comply with the following:
 - (i) Roof *flashings* and cappings must be purpose made, machine-folded sheet metal sections of material compatible with all up and downstream metal roof covering materials in accordance with [3.5.1.2\(b\)](#).

Roof and Wall Cladding

- (ii) The type of fasteners for *flashing* and cappings must comply with 3.5.1.5.
- (iii) The fastener and fixing frequency for *flashings* and cappings must comply with Table 3.5.1.5.

Table 3.5.1.5 Fastener frequency for flashings and cappings

Roof type	Fixing frequency	Fastener type
Concealed fastener roofs	Every rib	Rivets and self drilling screws
Pierced fastener roofs	Every second rib	Self drilling screws or rivets
Corrugated roofs	Every fourth rib	Self drilling screws or rivets

- (iv) Joints in *flashings* and cappings must be not less than 75 mm, lapped in the direction of the fall of the roof, and fastened at intervals not more than 40 mm.
- (v) Wall and step *flashings* must be fastened into masonry walls with galvanized or zinc/aluminium sheet metal wedges at each end of each length and at intermediate intervals of not more than 500 mm and must overlap by not less than 75 mm in the direction of flow.
- (vi) Lead *flashings* must not be used with prepainted steel or zinc/aluminium steel or on any roof if the roof is part of a potable (drinking) water catchment area.
- (vii) Anti-capillary breaks must be installed in accordance with Figure 3.5.1.5 and be—
 - (A) for flat surfaces – 10 mm/30 degree fold; and
 - (B) all other surfaces – 10 mm/90 degree or 135 degree fold.

Figure 3.5.1.5 Anti-capillary breaks

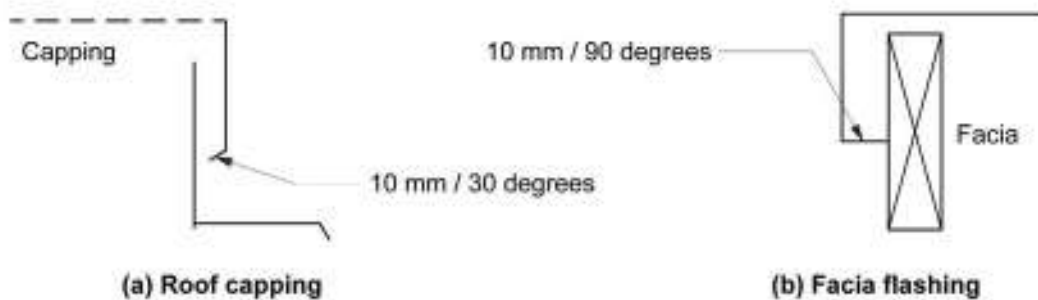

- (viii) Acceptable *flashing* configurations are shown in Figure 3.5.1.6a and Figure 3.5.1.6b.

Roof and Wall Cladding

Figure 3.5.1.6a Parapet flashing—Acceptable flashing details

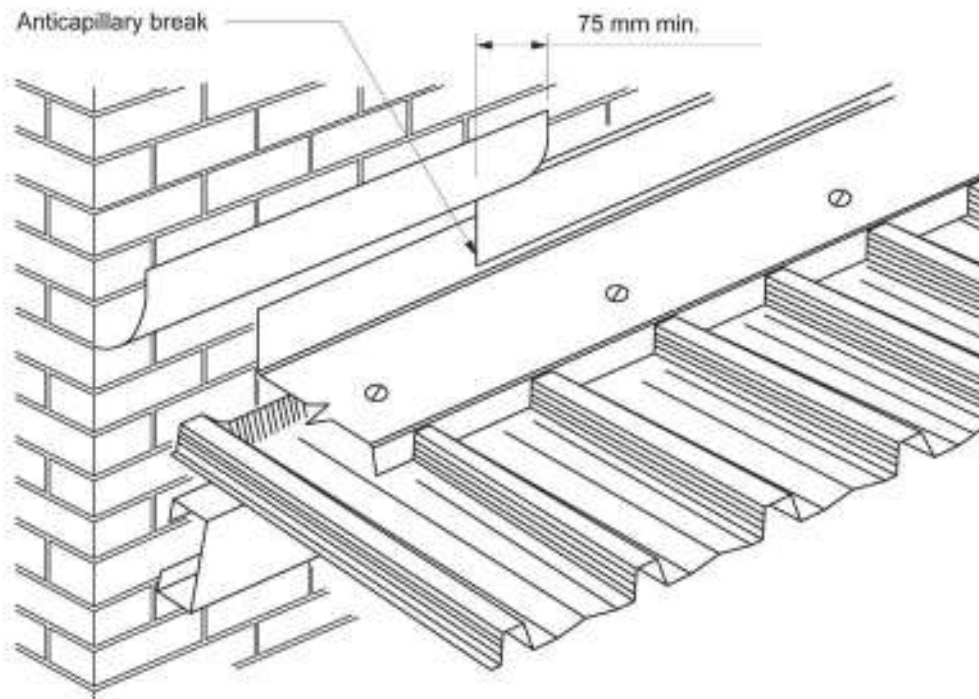
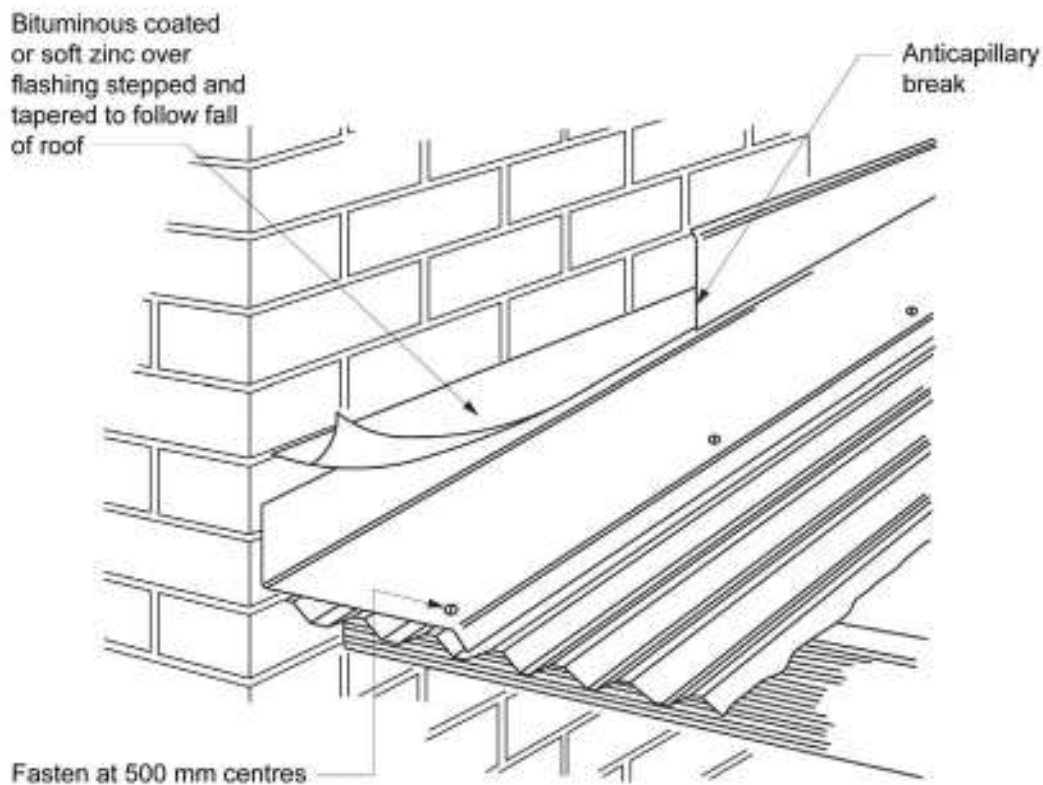

Figure 3.5.1.6b Parapet and end wall flashing—Acceptable flashing details



(b) *Flashing* of penetrations must comply with the following:

- (i) Collar *flashings* must permit the total drainage of the area above the penetration.
- (ii) On completion of installation, the roof structure must be restored to its original strength by installing roof trimmers

Roof and Wall Cladding

and soaker supports as necessary.

- (iii) The type of fasteners for *flashings* and cappings must comply with 3.5.1.5.
- (iv) Lead *flashings* must not be used with prepainted steel or zinc/aluminium steel or on any roof if the roof is part of a potable *drinking water* catchment area.
- (v) Acceptable *flashings* for penetrations are shown in Figure 3.5.1.7.
- (vi) Clearance for heating appliance roof support members must be in accordance with Part 3.10.7.

Figure 3.5.1.7a PVC aprons—Typical roof penetration flashing details

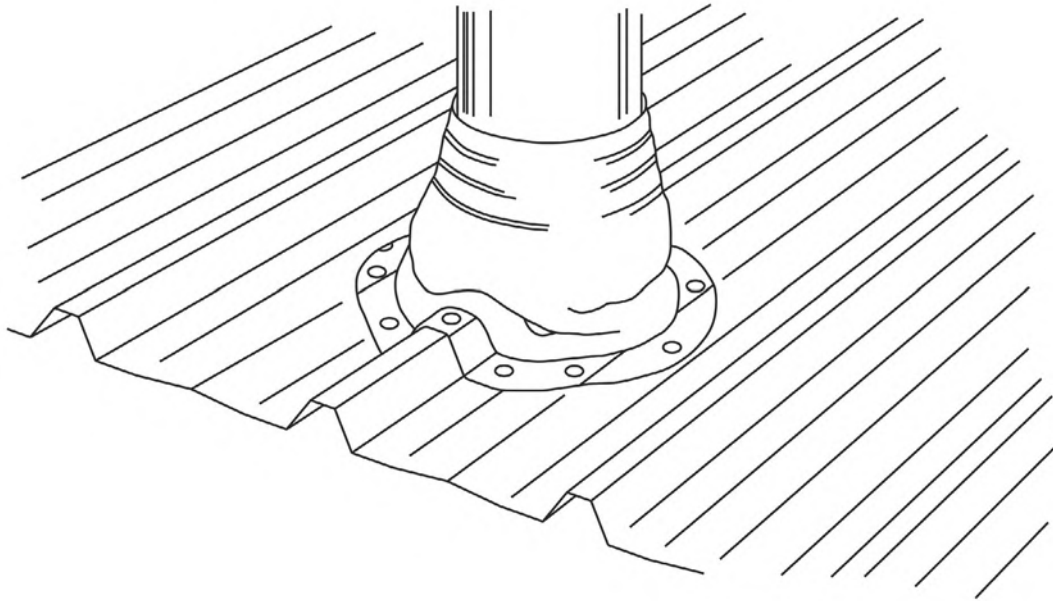

Roof and Wall Cladding

Figure 3.5.1.7b Collar flashings—Typical roof penetration flashing details

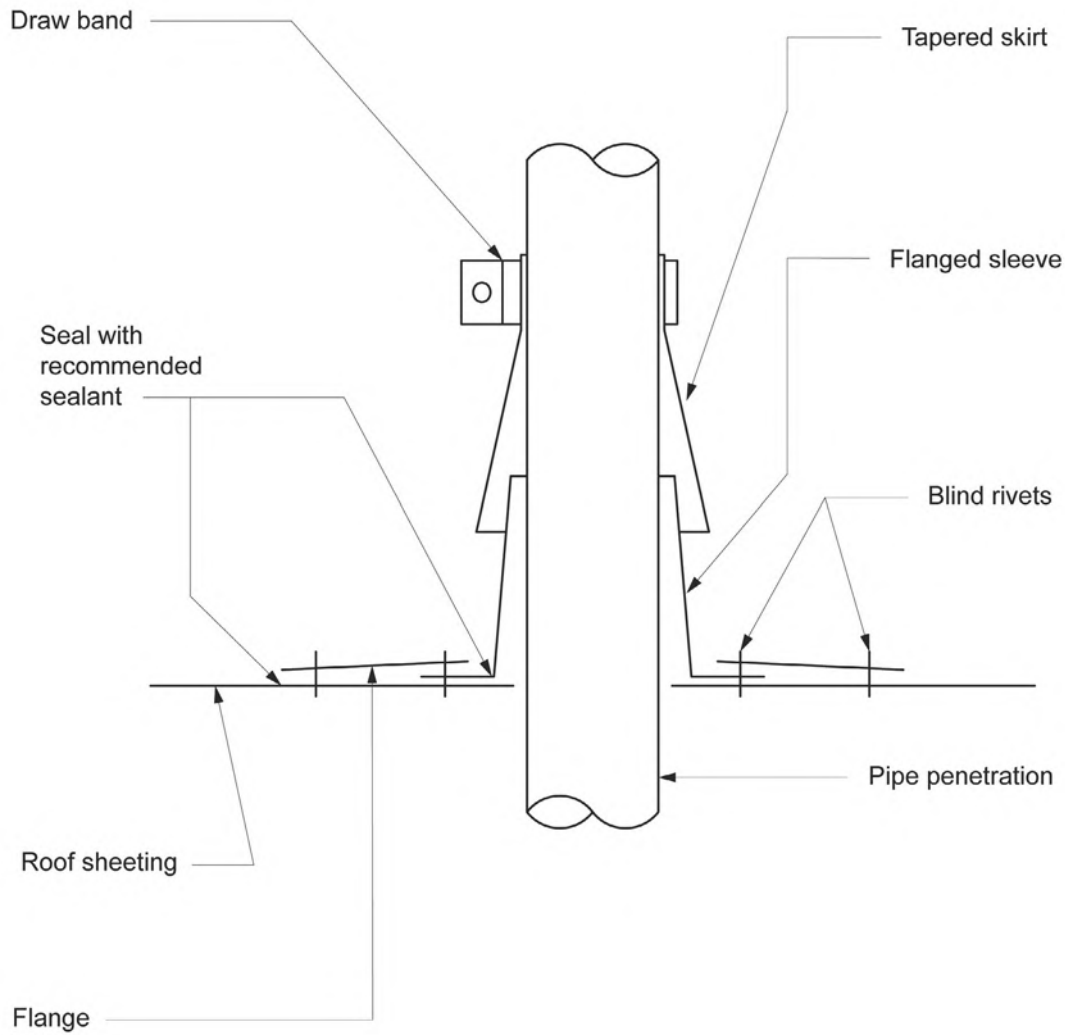
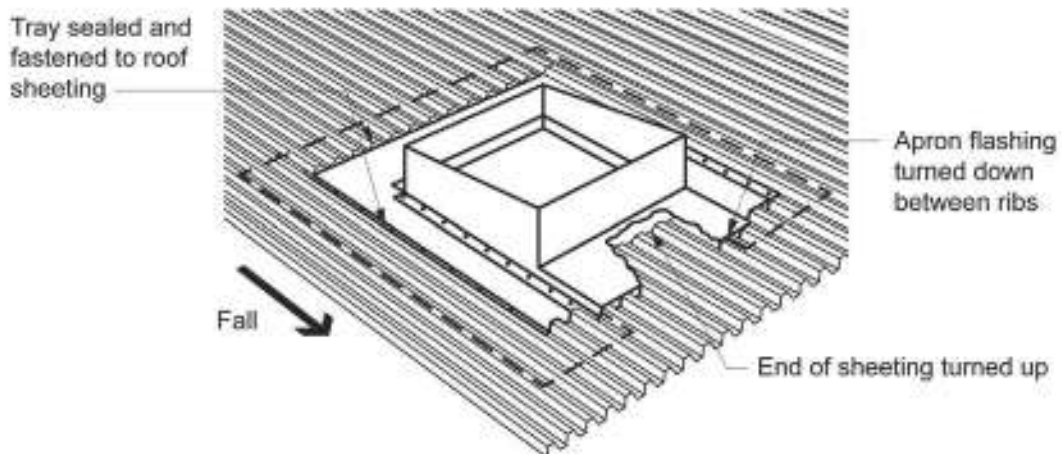

Figure 3.5.1.7c Large penetrations - using apron—typical roof penetration flashing details



3.5.1.8 Water discharge

Where an eaves gutter is provided in accordance with [Part 3.5.3](#), sheets must overhang the fascia, or end batten where

Roof and Wall Cladding

there is no fascia, by not less than 35 mm.

Part 3.5.2 Roof tiles and shingles

Appropriate *Performance Requirements*

Where an alternative roof cladding is proposed as a *Performance Solution* to that described in [Part 3.5.1](#), that proposal must comply with—

- (a) *Performance Requirement P2.1.1*; and
- (b) *Performance Requirement P2.2.2*; and
- (c) the relevant *Performance Requirements* determined in accordance with [A2.2\(3\)](#) and [A2.4\(3\)](#) as applicable.

Acceptable Construction Manuals

3.5.2.0 Application

Performance Requirements P2.1.1 and *P2.2.2* are satisfied for roof cladding if it complies with one or a combination of the following:

- (a) Roof tiling: AS 2050.
- (b) Terracotta, fibre-cement and timber slates and shingles: AS 4597.

Acceptable Construction Practice

3.5.2.1 Application

Compliance with this acceptable construction practice satisfies *Performance Requirements P2.1.1* and *P2.2.2* for roof tiles, provided—

- (a) the building is located in an area with a *design wind speed* of not more than N3; and
- (b) the roof tiles comply with AS 2049; and
- (c) the roof has a pitch of not less than 15 degrees and not more than 35 degrees; and
- (d) the roof tiles are installed in accordance with the provisions of this Part.

Explanatory information:

1. Design wind speeds:

Information on *design wind speed* for particular areas may be available from the *appropriate authority*. Also see [Table 3](#) for wind classes. A map indicating wind regions of Australia is contained in [Part 3.0](#).

2. Other relevant roof tile requirements:

A number of other Parts of Volume Two contain specific requirements relevant to roof tiles, in addition to the provisions of this Part. They include—

- a. for the sizing and fixing of roof battens—
 - i. [Part 3.4.2](#) for steel battens; and
 - ii. [Part 3.4.3](#) for timber battens; and
- b. [Part 3.7.3](#) for roofing over a *separating wall*; and
- c. [Part 3.5.3](#) for gutters and downpipes.

3.5.2.2 Fixing of roof tiles and ancillaries

- (a) Roof tiles and hip, ridge, barge and capping tiles must be fixed in accordance with [Table 3.5.2.1](#) and [Figures 3.5.2.1](#) and [3.5.2.2](#).
- (b) Fixing *required* by [Table 3.5.2.1](#) must consist of one or a combination of the following:
 - (i) Galvanized clout nails with a minimum diameter of 2.8 mm and of a length so that the nail will penetrate not less than 15 mm into the batten.
 - (ii) Self embedding head screws of 8-18 gauge and of a length so that the screw will penetrate not less than 15

Roof and Wall Cladding

mm into the batten.

- (iii) Purpose made clips of non-ferrous metal, stainless steel or steel protected from corrosion in accordance with [Tables 3.5.1.2a](#) and [3.5.1.2b](#).
- (iv) Flexible pointing material complying with AS 2050.

Table 3.5.2.1 Minimum fixing requirements

<i>Design wind speed</i>	Tile fixing - edge of roof	Tile fixing - field of roof	Ridge, hip, barge and valley tiles including capping (see Figure 3.5.2.2)
N1 and N2	Fix every full tile in second course in from the edge of roof (a)	In field of roof fix— (a) every second tile in every course; or (b) every tile in each alternative course. (see Figure 3.5.2.1b)	Fix each tile
N3	Fix each full tile in every second course starting from the second course in (see Figure 3.5.2.1c)	Fix every second full tile in every course (see Figure 3.5.2.1c)	Fix each tile

Note to [Table 3.5.2.1](#): Refer to [Figure 3.5.2.1](#) for determination of “edge of roof” and “field of roof”.

Figure 3.5.2.1 Fixing of tile requirements

Diagram a Identification of field and edge of roof

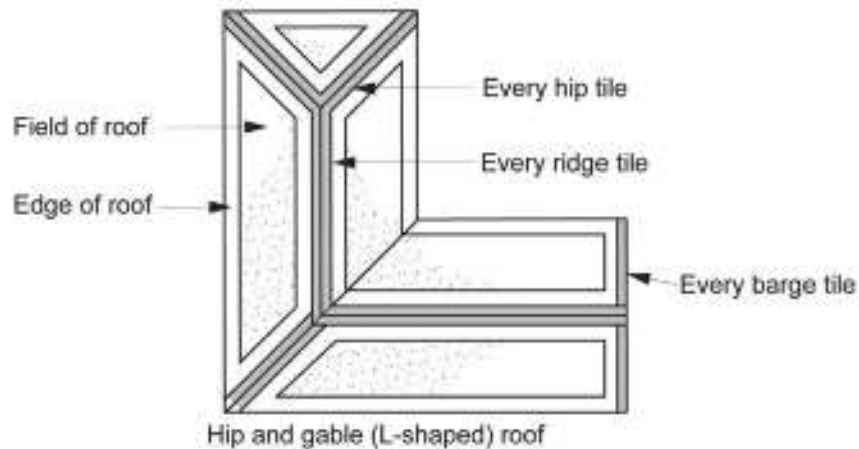

Roof and Wall Cladding

Diagram b Minimum tile fixing requirements N1/N2

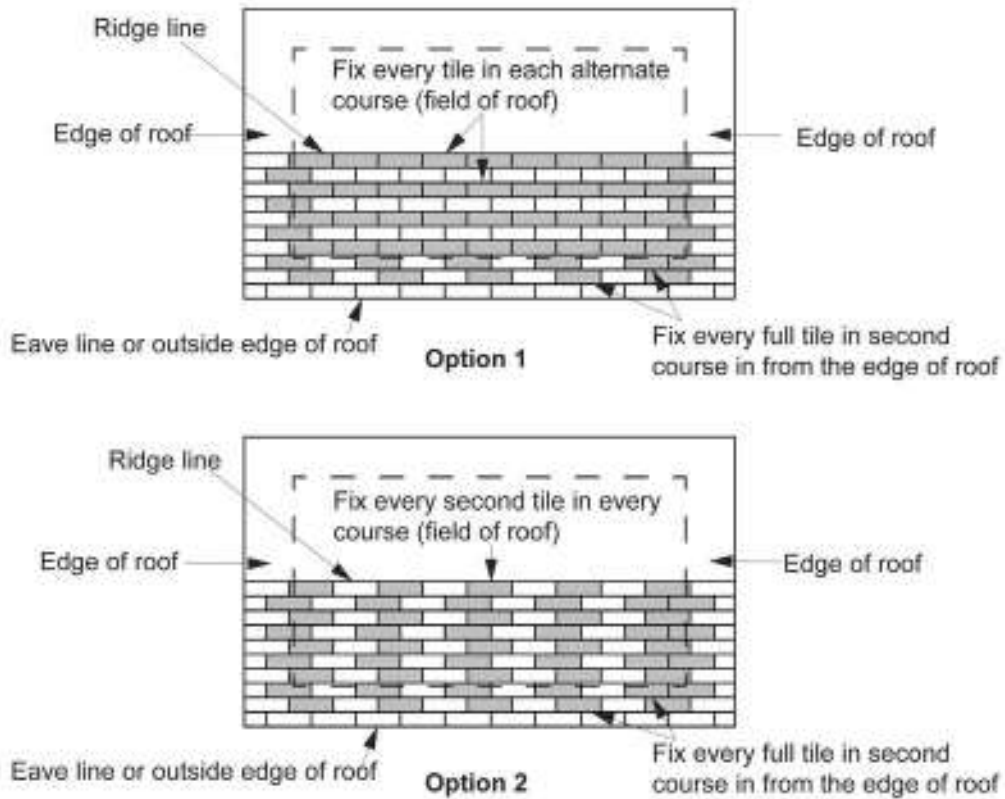
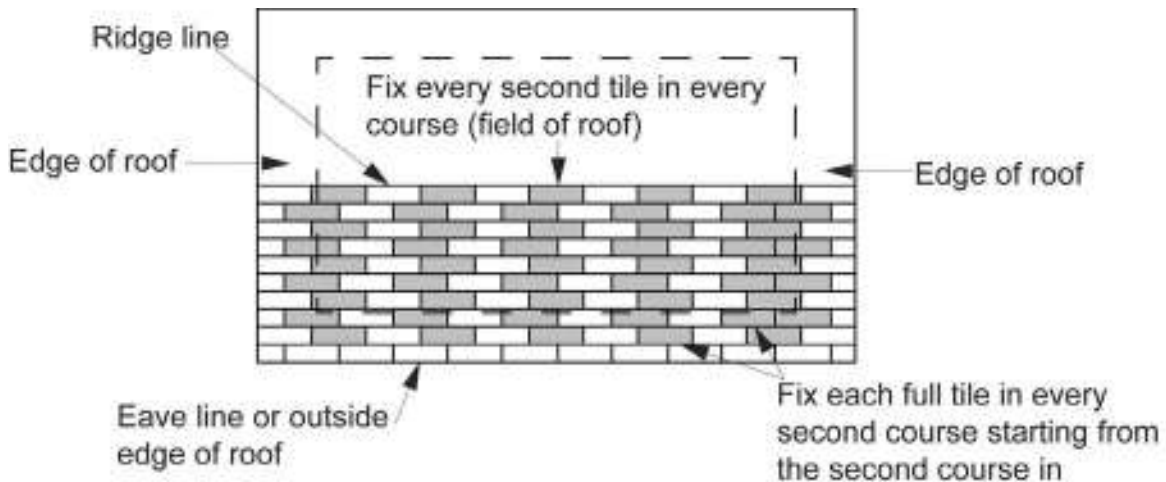

Diagram c Minimum tile fixing requirements N3



Explanatory information:

For the purpose of this Figure, "edge of roof" is a 1.2 m wide band bounded by the eaves, hips and barge measured towards the "ridge of roof".

Roof and Wall Cladding

Figure 3.5.2.2 Fixing of ridge and hip capping

Diagram a Fixing of ridge capping—ridge clip fixing

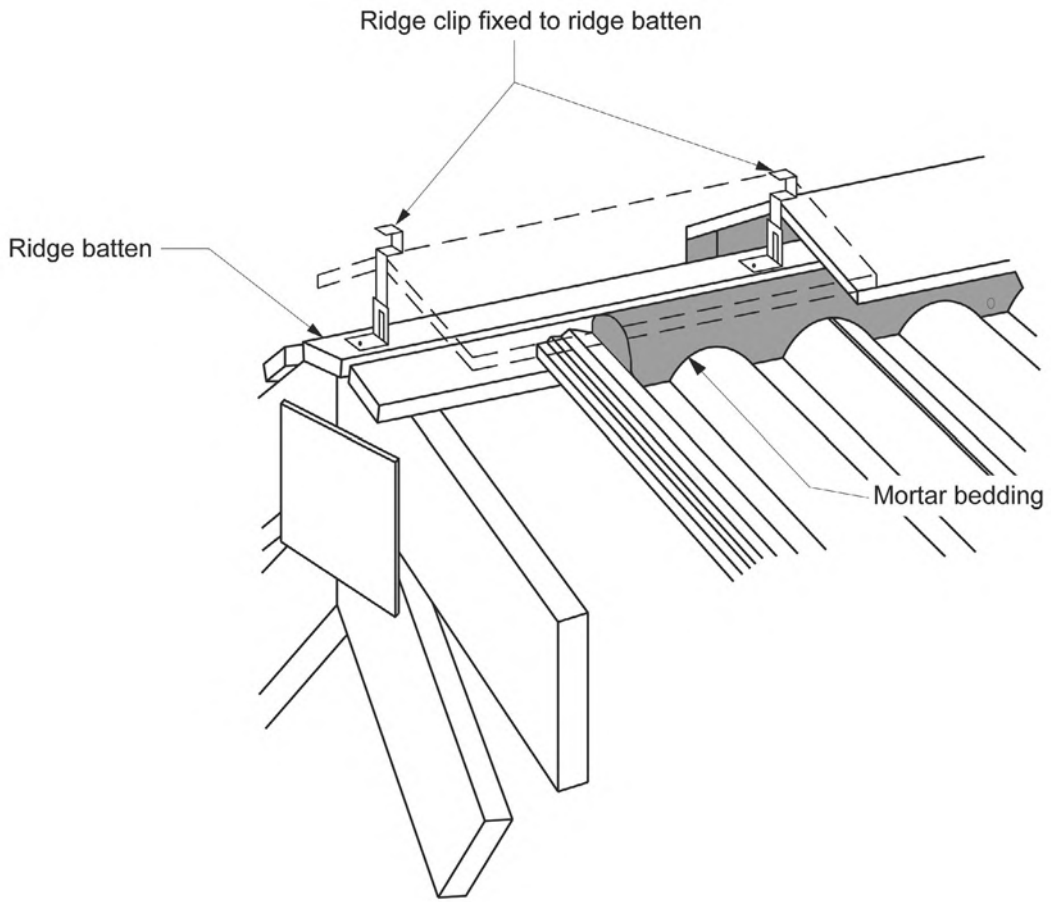
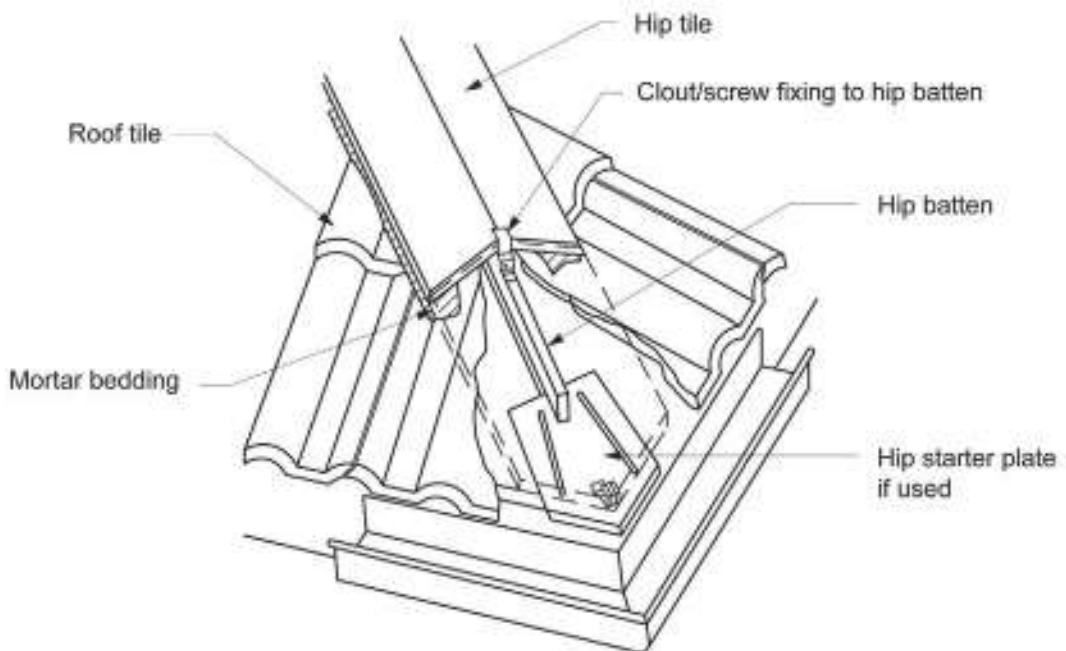

Diagram b Fixing of hip capping—clout or screw fixing



3.5.2.3 Flashing

Flashing for roof tiles must comply with the following:

- (a) Wall and step *flashings*:
 - (i) For masonry or similar walls, *flashing* must—
 - (A) follow the roof line, allowing not less than 75 mm upturn to the wall and a minimum of 150 mm in width and moulded into the tiles; and
 - (B) have a horizontal overflashing, stepped overflashing or raked overflashing built into the masonry leaf or veneer, except that one continuous *flashing* may be used as both an apron *flashing* or an overflashing; and
 - (C) have joints overlap the one below by not less than 75 mm in the direction of flow.
 - (ii) For *flashing* where the upturn can be fixed to or behind the supporting frame or cladding, it must—
 - (A) follow the roof line, allowing not less than 75 mm upturn to the wall and a minimum of 150 mm in width and moulded into the tiles; and
 - (B) be fastened into or behind the wall cladding at each end and at a maximum of 600 mm centres; and
 - (C) have joints overlap the one below by not less than 75 mm in the direction of flow.
- (b) *Flashing* of penetrations must—
 - (i) be either collar, apron or other purpose made *flashings*; and
 - (ii) have a minimum upturn on the penetration of not less than 75 mm and a minimum of 150 mm in width surrounding the penetration and be moulded into the tiles; and
 - (iii) permit the total drainage of the area above the penetration.
- (c) Joints in *flashing* must be not less than 75 mm and lapped in the direction of fall of the roof.
- (d) Fixings for *flashings* must be compatible with the *flashing* material.
- (e) Lead *flashings* must not be used on any roof that is part of a potable *drinking water* catchment area.
- (f) Acceptable *flashing* configurations, including typical details for standard, and bedded and pointed valleys, are shown in Figure 3.5.2.3.

Figure 3.5.2.3 Acceptable flashing details

Diagram a Flashing abutting a masonry wall

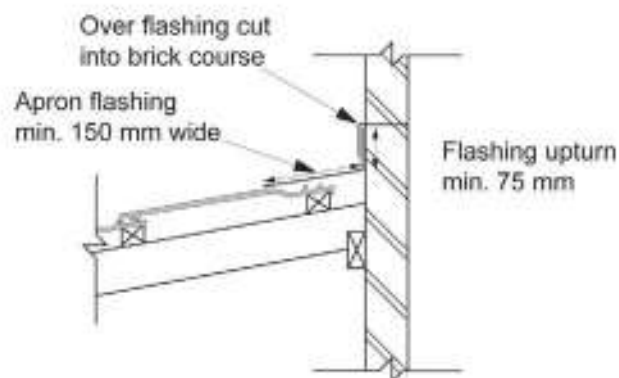

Roof and Wall Cladding

Diagram b Flashing abutting a weatherboard wall or similar cladding

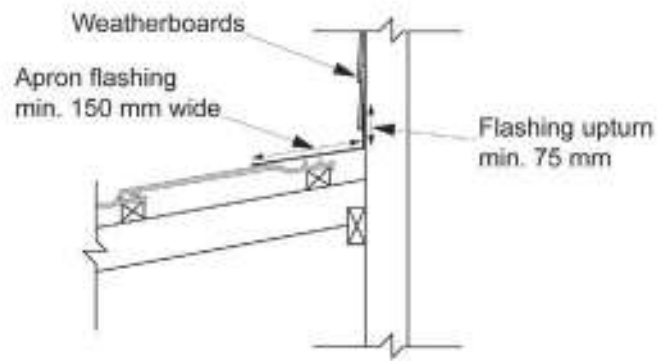
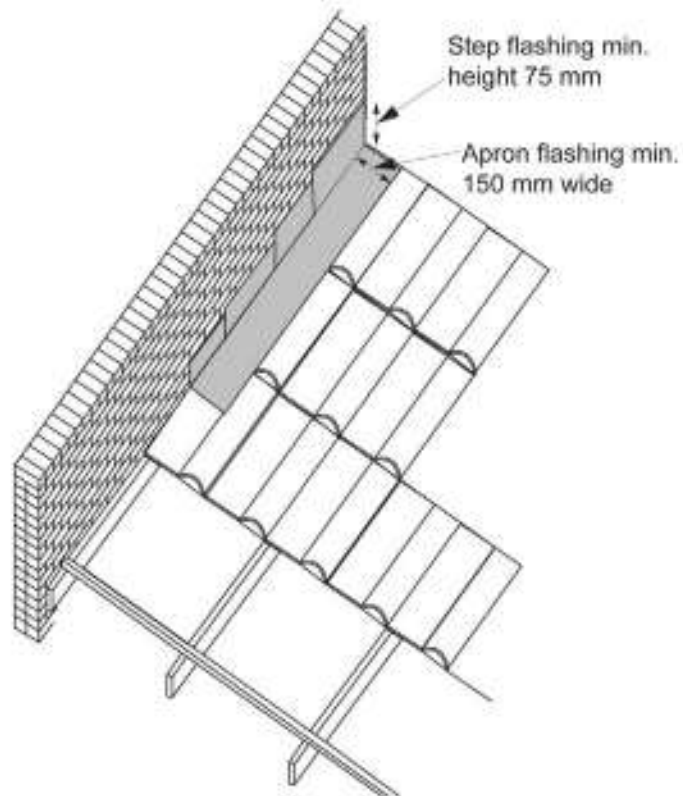

Diagram c Stepped flashing to a masonry wall



Roof and Wall Cladding

Diagram d Pipe penetration flashing

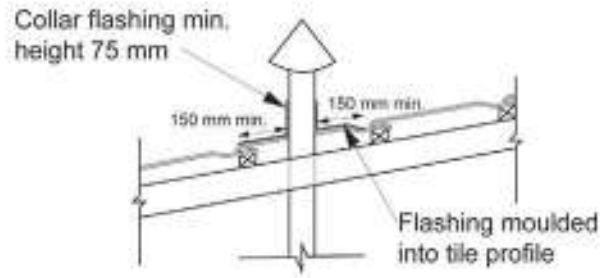
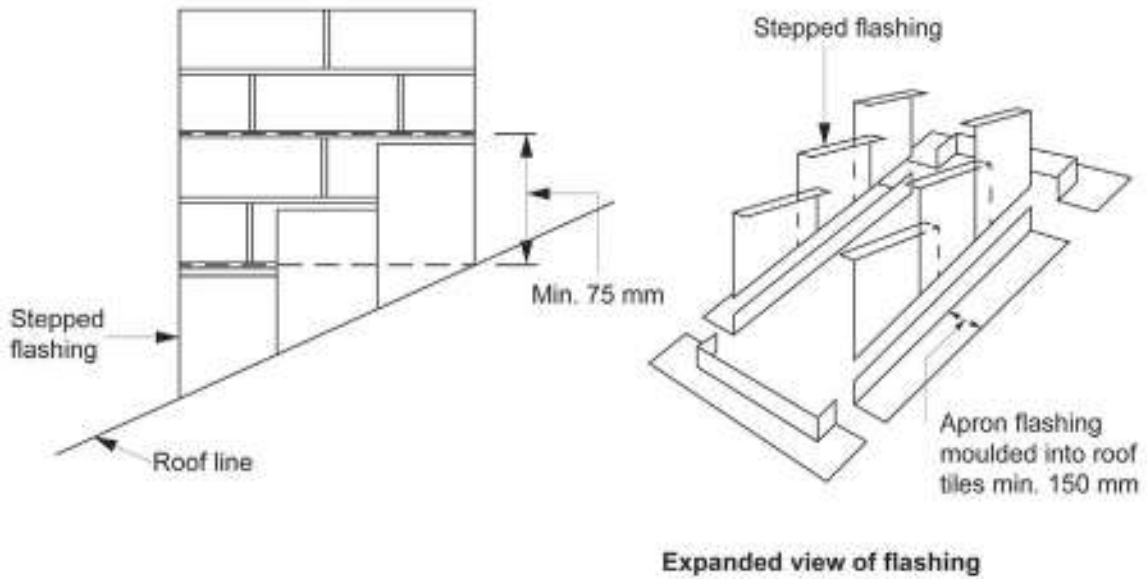

Diagram e Chimney flashing



Roof and Wall Cladding

Diagram f Standard valley

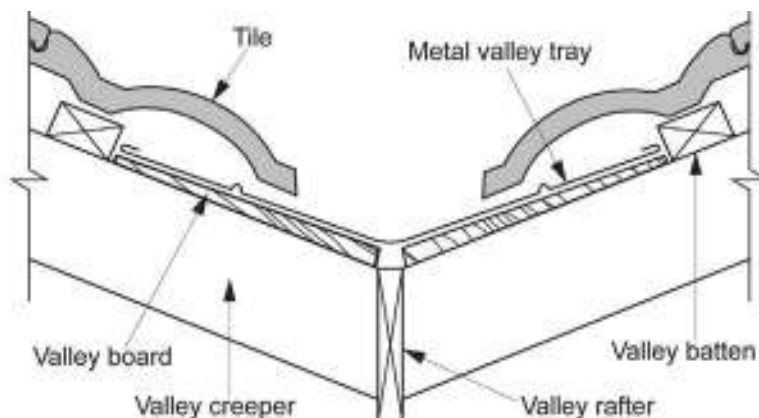
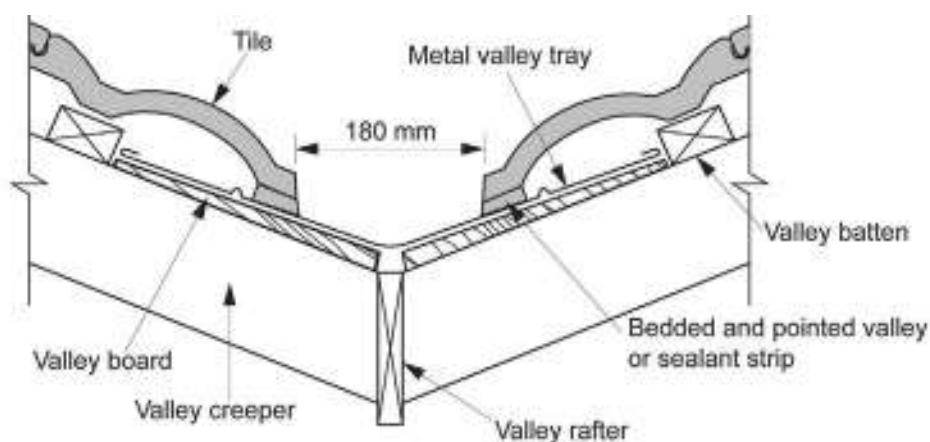

Diagram g Bedded and pointed valley for high rainfall areas (refer definition of low rainfall intensity area)



3.5.2.4 Sarking

Sarking must—

- (a) be provided in accordance with [Table 3.5.2.2](#); and
- (b) comply with AS/NZS 4200.1 and be installed with—
 - (i) each adjoining sheet or roll being—
 - (A) overlapped not less than 150 mm; or
 - (B) taped together; and
 - (ii) sarking fixed to supporting members at not more than 300 mm centres; and
 - (iii) no sags greater than 40 mm in the sarking.

Table 3.5.2.2 Sarking requirements for tiled roofs

Roof pitch	Maximum rafter/truss top chord length without sarking (mm) ^{Note 1}
<18°	N/A ^{Note 2}
>18° <20°	4 500
>20° <22°	5 500
>22°	6 000

Notes to [Table 3.5.2.2](#):

1. The maximum rafter/truss top chord length is measured from the topmost point of the rafter/truss i.e. the apex downwards. Where the maximum length is exceeded, sarking must be installed over the remainder of the rafter/truss top chord length towards the eave line of the roof, or equivalent where the building has no eaves.

Roof and Wall Cladding

2. All tiled roofs with a pitch less than 18 degrees must be provided with sarking, regardless of rafter/truss chord length.

Explanatory information:

Where sarking is also provided as *reflective insulation* for the purpose of energy efficiency, [Part 3.12](#) contains *required R-Values* and the necessary airspaces adjoining the *reflective insulation*.

3.5.2.5 Anti-ponding device/board

- (a) An anti-ponding device/board must be provided—
- on sarked roofs with a pitch less than 20°; and
 - on all roof pitches where there is no eaves overhang, regardless of whether sarking is *required*.
- (b) An anti-ponding device/board *required* by (a) must be *water resistant* and fixed along the eaves line from the top of the fascia back up the rafter with a clearance of approximately 50 mm below the first batten (See [Figure 3.5.2.4](#)).

3.5.2.6 Water discharge

Where an eaves gutter is provided in accordance with [Part 3.5.3](#), tiles must overhang the fascia or tiling batten by not less than 35 mm (See [Figure 3.5.2.4](#)).

Figure 3.5.2.4 Typical installation of anti-ponding device/board

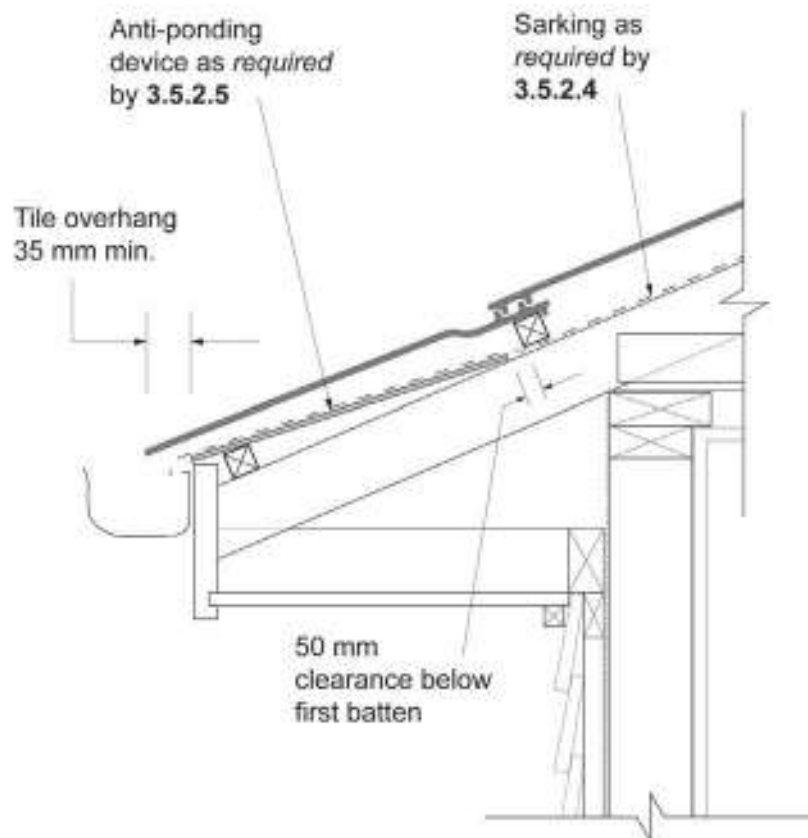

Part 3.5.3 Gutters and downpipes

Appropriate *Performance Requirements*

Where an alternative gutter and downpipe system is proposed as a *Performance Solution* to that described in [Part 3.5.2](#), that proposal must comply with—

- (a) *Performance Requirement P2.2.1*; and
- (b) the relevant *Performance Requirements* determined in accordance with [A2.2\(3\)](#) and [A2.4\(3\)](#) as applicable.

Acceptable Construction Manuals

3.5.3.0 Application

Performance Requirement P2.2.1 is satisfied for gutters and downpipes if they are designed and constructed in accordance with AS/NZS 3500.3.

State and Territory Variations

In Victoria, except for [3.5.3.0](#) - Acceptable construction manuals, [Part 3.5.3](#) does not apply.

Acceptable Construction Practice

3.5.3.1 Application

- (a) Compliance with this acceptable construction practice satisfies *Performance Requirement P2.2.1* for gutters and downpipes provided the roof drainage system is connected to a stormwater drainage system that complies with [Part 3.1.2](#).
- (b) This Part does not apply to the removal of *surface water* from a storm having an *average recurrence interval* of 100 years for a Class 10 building where in the particular case there is no necessity for compliance.

Explanatory information:

1. The requirement to install drainage systems from roofs and sub-soil drains should be confirmed with the *appropriate authority*. These provisions need only be applied when drainage systems are necessary.
2. Information on drainage requirements outside the allotment can be obtained from the *appropriate authority*.

3.5.3.2 Materials

Gutters, downpipes and *flashings* must—

- (a) be manufactured in accordance with AS/NZS 2179.1 for metal; and
- (b) be manufactured in accordance with AS 1273 for UPVC components; and
- (c) be compatible with all upstream roofing materials in accordance with [3.5.1.2\(b\)](#); and
- (d) not contain any lead if used on a roof forming part of a potable water catchment area.

3.5.3.3 Selection of guttering

The size of guttering must—

- (a) for eaves gutters, be in accordance with [Table 3.5.3.2a](#) to [Table 3.5.3.2c](#); and
- (b) for box gutters, be in accordance with AS/NZS 3500.3; and
- (c) be suitable to remove rainwater falling at the appropriate 5 minute duration rainfall intensity listed in [Table 3.5.3.1a](#) to [Table 3.5.3.1h](#) as follows—
 - (i) for eaves gutters — 20 year *average recurrence interval*; and
 - (ii) for eaves gutter overflow measures — 100 year *average recurrence interval*; and
 - (iii) for box and valley gutters — 100 year *average recurrence interval*.

Roof and Wall Cladding

3.5.3.4 Installation of gutters

- (a) Gutters must be installed with a fall of not less than—
 - (i) 1:500 for eaves gutters, unless fixed to metal fascias; and
 - (ii) 1:100 for box gutters.
- (b) Eaves gutters must be—
 - (i) supported by brackets securely fixed at stop ends and at not more than 1.2 m centres; and
 - (ii) be capable of removing the overflow volume specified in [Table 3.5.3.3a](#) and [Table 3.5.3.3b](#).
- (c) Overflow measures in accordance with [Table 3.5.3.4a](#) and [Table 3.5.3.4b](#) are deemed to be capable of removing the overflow volume specified in that Table.
- (d) Valley gutters on a roof with a pitch—
 - (i) more than 12.5 degrees — must have width of not less than 400 mm and be wide enough to allow the roof covering to overhang not less than 150 mm each side of the gutter; or
 - (ii) not more than 12.5 degrees — must be designed as a box gutter.
- (e) The requirement of (b)(ii) does not apply to eaves gutters fixed to a verandah or an eave that is greater than 450 mm in width, which—
 - (i) has no lining; or
 - (ii) is a raked verandah or a raked eave with a lining sloping away from the building.

Explanatory information:

Worked example — Determining appropriate overflow measures

The location of a proposed building is in Wollongong, NSW. Using [Table 3.5.3.1b](#) the 5 minute duration rainfall intensity for a 100 year *average recurrence interval* is 308 mm/h. The 5 minute duration rainfall intensities in [Table 3.5.3.3a](#) and [Table 3.5.3.3b](#) are provided in 25 mm/h increments, therefore for the purpose of the worked example 325 mm/h will be used.

[Table 3.5.3.3a](#) and [Table 3.5.3.3b](#) provide *required* overflow volumes in both litres per second for dedicated overflow measures and litres per second per metre for continuous overflow measures. Where both dedicated and continuous measures are proposed, [Table 3.5.3.3b](#) can be used to determine the *required* overflow volume.

1. Multiple overflow measures are proposed to be used with a roof catchment area of 60 m², incorporating a 10 m eaves gutter.
2. Using [Table 3.5.3.3b](#) for a 325 mm/h 5 minute duration rainfall intensity, the overflow volume in litres per second (L/s) for a roof catchment area of 60 m² is 5.4 L/s.
3. Select an acceptable dedicated overflow measure from [Table 3.5.3.4b](#).
The selected dedicated overflow measure is an end-stop weir which provides 0.5 L/s.
One end-stop weir does not achieve the *required* overflow volume of 5.4 L/s, and additional overflow measures are *required* to remove the overflow volume.
4. To achieve the *required* overflow volume a continuous overflow measure is also selected from [Table 3.5.3.4a](#).
A front face slotted gutter is the selected overflow measure as it provides 0.5 L/s/m. Taking account of the eaves gutter length (10 m), the combined overflow measures (0.5 L/s for the end-stop weir and 0.5 L/s/m × 10 m) will remove up to 5.5 L/s.
5. The 5.5 L/s capacity provided by the selected overflow measures exceeds the *required* 5.4 L/s overflow volume.

3.5.3.5 Downpipes — size and installation

Downpipes must—

- (a) not serve more than 12 m of gutter length for each downpipe; and
- (b) be located as close as possible to valley gutters; and
- (c) be selected in accordance with the appropriate eaves gutter section as shown in [Table 3.5.3.2a](#) to [Table 3.5.3.2c](#).

Explanatory information:

Roof and Wall Cladding

A maximum 12 m gutter length served by each downpipe is to ensure effective fall and adequate capacity to discharge all water anticipated during a storm having an *average recurrence interval* of 20 years.

Where a rainhead overflow device is incorporated in the top of the downpipe, its overflow discharge should be directed away from the building.

Table 3.5.3.1a 5 minute duration rainfall intensities for the Australian Capital Territory

Locality	<i>Average recurrence interval</i> , once in 20 years (mm/h)	<i>Average recurrence interval</i> , once in 100 years (mm/h)
Canberra	143	193
Gungahlin	137	179
Tuggeranong	148	210

Note to Table 3.5.3.1a: Locations used in this table are based on the nearest Bureau of Meteorology grid cell latitude and longitude to the central Post Office of each city or town.

Table 3.5.3.1b 5 minute duration rainfall intensities for New South Wales

Locality	<i>Average recurrence interval</i> , once in 20 years (mm/h)	<i>Average recurrence interval</i> , once in 100 years (mm/h)
Albury	139	180
Broken Hill	143	219
Goulburn	121	156
Kiama	226	319
Newcastle	226	316
Orange	142	186
Sydney	200	262
Avalon, Sydney	206	278
Campbelltown, Sydney	167	222
Penrith, Sydney	180	244
Windsor, Sydney	175	233
Tweed Heads	252	330
Wollongong	217	308

Note to Table 3.5.3.1b: Locations used in this table are based on the nearest Bureau of Meteorology grid cell latitude and longitude to the central Post Office of each city or town.

Table 3.5.3.1c 5 minute duration rainfall intensities for the Northern Territory

Locality	<i>Average recurrence interval</i> , once in 20 years (mm/h)	<i>Average recurrence interval</i> , once in 100 years (mm/h)
Alice Springs	166	239
Darwin	233	274
Katherine	216	250

Note to Table 3.5.3.1c: Locations used in this table are based on the nearest Bureau of Meteorology grid cell latitude and longitude to the central Post Office of each city or town.

Table 3.5.3.1d 5 minute duration rainfall intensities for Queensland

Locality	<i>Average recurrence interval</i> , once in 20 years (mm/h)	<i>Average recurrence interval</i> , once in 100 years (mm/h)
Bamaga	252	298
Brisbane	234	305
Ipswich, Brisbane	211	278
Victoria Point, Brisbane	245	320
Bundaberg	265	340
Cairns	229	278

Roof and Wall Cladding

Locality	<i>Average recurrence interval, once in 20 years (mm/h)</i>	<i>Average recurrence interval, once in 100 years (mm/h)</i>
Cloncurry	218	278
Innisfail	248	301
Mackay	250	316
Mt Isa	199	260
Noosa Heads	258	331
Rockhampton	229	300
Toowoomba	203	268
Townsville	235	300
Weipa	239	283

Note to Table 3.5.3.1d: Locations used in this table are based on the nearest Bureau of Meteorology grid cell latitude and longitude to the central Post Office of each city or town.

Table 3.5.3.1e 5 minute duration rainfall intensities for South Australia

Locality	<i>Average recurrence interval, once in 20 years (mm/h)</i>	<i>Average recurrence interval, once in 100 years (mm/h)</i>
Adelaide	124	184
Gawler, Adelaide	110	158
Mt Gambier	103	144
Murray Bridge	120	178
Port Augusta	133	199
Port Pirie	122	181
Yorketown	155	166

Note to Table 3.5.3.1e: Locations used in this table are based on the nearest Bureau of Meteorology grid cell latitude and longitude to the central Post Office of each city or town.

Table 3.5.3.1f 5 minute duration rainfall intensities for Tasmania

Locality	<i>Average recurrence interval, once in 20 years (mm/h)</i>	<i>Average recurrence interval, once in 100 years (mm/h)</i>
Burnie	128	180
Flinders Island	122	166
Hobart	85	116
Launceston	90	121
Queenstown	94	120
St. Marys	146	203

Note to Table 3.5.3.1f: Locations used in this table are based on the nearest Bureau of Meteorology grid cell latitude and longitude to the central Post Office of each city or town.

Table 3.5.3.1g 5 minute duration rainfall intensities for Victoria

Locality	<i>Average recurrence interval, once in 20 years (mm/h)</i>	<i>Average recurrence interval, once in 100 years (mm/h)</i>
Ballarat	131	188
Benalla	146	194
Geelong	102	144
Horsham	120	173
Lakes Entrance	145	198
Melbourne	132	187
Hastings, Melbourne	117	145
Sorrento, Melbourne	106	140
Mildura	142	218

Roof and Wall Cladding

Locality	Average recurrence interval, once in 20 years (mm/h)	Average recurrence interval, once in 100 years (mm/h)
Stawell	130	186

Note to Table 3.5.3.1g: Locations used in this table are based on the nearest Bureau of Meteorology grid cell latitude and longitude to the central Post Office of each city or town.

Table 3.5.3.1h 5 minute duration rainfall intensities for Western Australia

Locality	Average recurrence interval, once in 20 years (mm/h)	Average recurrence interval, once in 100 years (mm/h)
Albany	125	178
Broome	232	287
Bunbury	147	199
Derby	211	256
Geraldton	138	193
Kalgoorlie	137	204
Perth	130	172
Joondalup, Perth	133	180
Midland, Perth	122	163
Port Hedland	168	230
Tom Price	138	182

Note to Table 3.5.3.1h: Locations used in this table are based on the nearest Bureau of Meteorology grid cell latitude and longitude to the central Post Office of each city or town.

Table 3.5.3.2a Size of gutter required to drain roof catchment area into one (1) downpipe for various rainfall intensities and roof catchment areas (A, B, C, D, E and F defined in Table 3.5.3.2b)

Design rainfall intensity (mm/h) (as per Table 3.5.2.1a to Table 3.5.2.1h)	Roof catchment area per downpipe — 30 m ²	Roof catchment area per downpipe — 40 m ²	Roof catchment area per downpipe — 50 m ²	Roof catchment area per downpipe — 60 m ²	Roof catchment area per downpipe — 70 m ²
90 mm/h	A or C	A or C	A or C	A or C	A or C
120 mm/h	A or C	A or C	A or C	A or C	A or D
140 mm/h	A or C	A or C	A or C	A or D	B or E
160 mm/h	A or C	A or C	A or C	A or E	B or E
175 mm/h	A or C	A or C	A or D	B or E	E
200 mm/h	A or C	A or C	A or D	B or E	F
225 mm/h	A or C	A or C	A or B	E	F
255 mm/h	A or C	A or D	B or E	E	F
275 mm/h	A or C	A or D	B or E	F	F
325 mm/h	A or C	B or E	F	F	F
425 mm/h	A or C	E	F	F	F

Table 3.5.3.2b Gutter sizes for various rainfall intensities

Gutter type	Gutter description	Minimum cross sectional area mm ²
A	Medium rectangular gutter	6500 mm ²
B	Large rectangular gutter	7900 mm ²
C	115 mm D gutter	5200 mm ²
D	125 mm D gutter	6300 mm ²
E	150 mm D gutter	9000 mm ²
F	Gutter must be designed in accordance with AS/NZS 3500.3	N/A

Roof and Wall Cladding

Table 3.5.3.2c Downpipe selection for gutter types (A, B, C, D, E and F defined in Table 3.5.3.2b)

Downpipe section	Gutter type A	Gutter type B	Gutter type C	Gutter type D	Gutter type E
75 mm dia.	Yes	Yes	Yes	Yes	No
100 mm × 50 mm	Yes	Yes	Yes	Yes	Yes
90 mm dia.	Yes	Yes	Yes	Yes	Yes
100 mm × 75 mm	Yes	Yes	Yes	Yes	Yes

Notes to Table 3.5.3.2c:

1. Yes—downpipe is suitable for the eaves gutter selection.
2. No—downpipe is not suitable for the eaves gutter selection.

Table 3.5.3.3a Overflow volume for continuous measure (L/s/m)

Design 5 minute duration rainfall intensity (mm/h) (from Table 3.5.2.1a to Table 3.5.2.1h)	Ridge to gutter length — 2 m	Ridge to gutter length — 4 m	Ridge to gutter length — 6 m	Ridge to gutter length — 8 m	Ridge to gutter length — 10 m	Ridge to gutter length — 12 m	Ridge to gutter length — 14 m	Ridge to gutter length — 16 m
150 mm/h	0.08 L/s/m	0.17 L/s/m	0.25 L/s/m	0.33 L/s/m	0.42 L/s/m	0.50 L/s/m	0.58 L/s/m	0.67 L/s/m
175 mm/h	0.10 L/s/m	0.19 L/s/m	0.29 L/s/m	0.39 L/s/m	0.49 L/s/m	0.58 L/s/m	0.68 L/s/m	0.67 L/s/m
200 mm/h	0.11 L/s/m	0.22 L/s/m	0.33 L/s/m	0.44 L/s/m	0.56 L/s/m	0.67 L/s/m	0.78 L/s/m	0.89 L/s/m
225 mm/h	0.13 L/s/m	0.25 L/s/m	0.38 L/s/m	0.50 L/s/m	0.63 L/s/m	0.75 L/s/m	0.88 L/s/m	1.0 L/s/m
250 mm/h	0.14 L/s/m	0.28 L/s/m	0.42 L/s/m	0.56 L/s/m	0.69 L/s/m	0.83 L/s/m	0.97 L/s/m	1.1 L/s/m
275 mm/h	0.15 L/s/m	0.31 L/s/m	0.46 L/s/m	0.61 L/s/m	0.76 L/s/m	0.92 L/s/m	1.1 L/s/m	1.2 L/s/m
300 mm/h	0.17 L/s/m	0.33 L/s/m	0.50 L/s/m	0.67 L/s/m	0.83 L/s/m	1.0 L/s/m	1.2 L/s/m	1.3 L/s/m
325 mm/h	0.18 L/s/m	0.36 L/s/m	0.54 L/s/m	0.72 L/s/m	0.90 L/s/m	1.1 L/s/m	1.3 L/s/m	1.4 L/s/m
350 mm/h	0.19 L/s/m	0.39 L/s/m	0.58 L/s/m	0.78 L/s/m	0.97 L/s/m	1.2 L/s/m	1.4 L/s/m	1.6 L/s/m
375 mm/h	0.21 L/s/m	0.42 L/s/m	0.63 L/s/m	0.83 L/s/m	1.0 L/s/m	1.3 L/s/m	1.5 L/s/m	1.7 L/s/m
400 mm/h	0.22 L/s/m	0.44 L/s/m	0.67 L/s/m	0.89 L/s/m	1.1 L/s/m	1.3 L/s/m	1.6 L/s/m	1.8 L/s/m

Table 3.5.3.3b Overflow volume for dedicated measure (L/s)

Design 5 minute duration rainfall intensity (mm/h) (from Table 3.5.2.1a to Table 3.5.2.1h)	Roof catchment area — 30 m ²	Roof catchment area — 40 m ²	Roof catchment area — 50 m ²	Roof catchment area — 60 m ²	Roof catchment area — 70 m ²
150 mm/h	1.3 L/s	1.7 L/s	2.1 L/s	2.5 L/s	2.9 L/s
175 mm/h	1.5 L/s	1.9 L/s	2.4 L/s	2.9 L/s	3.4 L/s
200 mm/h	1.7 L/s	2.2 L/s	2.8 L/s	3.3 L/s	3.9 L/s
225 mm/h	1.9 L/s	2.5 L/s	3.1 L/s	3.8 L/s	4.4 L/s
250 mm/h	2.1 L/s	2.8 L/s	3.5 L/s	4.2 L/s	4.9 L/s
275 mm/h	2.3 L/s	3.1 L/s	3.8 L/s	4.6 L/s	5.3 L/s
300 mm/h	2.5 L/s	3.3 L/s	4.2 L/s	5.0 L/s	5.8 L/s
325 mm/h	2.7 L/s	3.6 L/s	4.5 L/s	5.4 L/s	6.3 L/s
350 mm/h	2.9 L/s	3.9 L/s	4.9 L/s	5.8 L/s	6.8 L/s
365 mm/h	3.1 L/s	4.2 L/s	5.2 L/s	6.3 L/s	7.3 L/s
400 mm/h	3.3 L/s	4.4 L/s	5.6 L/s	6.7 L/s	7.8 L/s

Roof and Wall Cladding

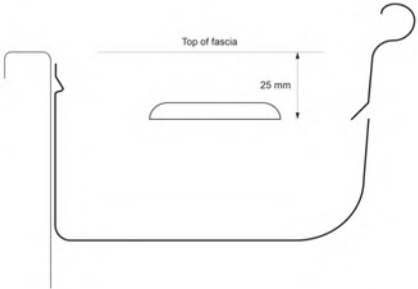
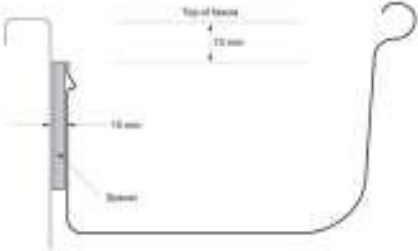
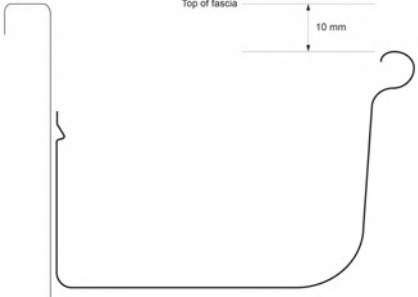
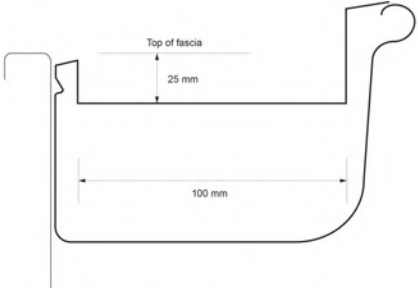

Table 3.5.3.4a Acceptable continuous overflow measure

Description	Overflow capacity (L/s/m)	Construction
<p>Front face slotted gutter with—</p> <p>(a) a minimum slot opening area of 1200 mm² per metre of gutter; and</p> <p>(b) the lower edge of the slots installed a minimum of 25 mm below the top of the fascia.</p>	<p>0.5</p>	
<p>Controlled back gap with—</p> <p>(a) a permanent minimum 10 mm spacer installed between the gutter back and the fascia; and</p> <p>(b) one spacer per bracket, with the spacer not more than 50 mm wide; and</p> <p>(c) the back of the gutter installed a minimum of 10 mm below the top of the fascia.</p>	<p>1.5</p>	
<p>Controlled front bead height with the front bead of the gutter installed a minimum of 10 mm below the top of the fascia.</p>	<p>1.5</p>	

Note to Table 3.5.3.4a:

For the controlled back gap option, the spacer can be a proprietary clip or bracket that provides the *required* offset of the gutter from the fascia.

Table 3.5.3.4b Acceptable dedicated overflow measure per downpipe

Description	Overflow Capacity (L/s)	Construction
<p>End-stop weir ^{Note 1} with—</p> <p>(a) a minimum clear width of 100 mm; and</p> <p>(b) the weir edge installed a minimum 25 mm below the top of the fascia.</p>	<p>0.5</p>	
<p>Inverted nozzle installed within 500 mm of a gutter high point with—</p> <p>(a) a minimum nozzle size of 100 mm × 50 mm positioned lengthways in the gutter; and</p>	<p>1.2</p>	

Roof and Wall Cladding

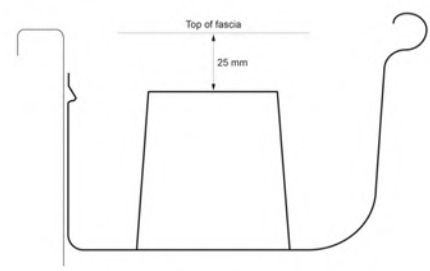
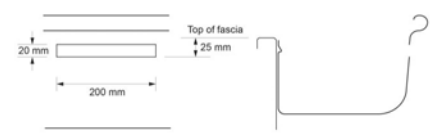
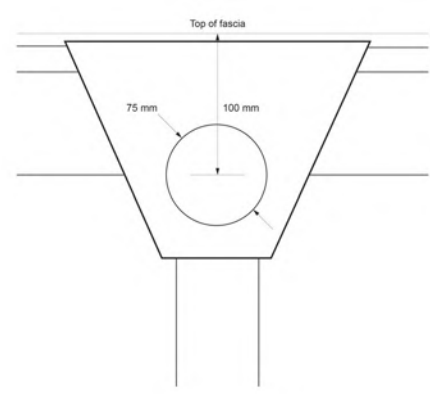
Description	Overflow Capacity (L/s)	Construction
(b) the top of the nozzle installed a minimum of 25 mm below the top of the fascia.		
Front face weir with— (a) a minimum clear width of 200 mm; and (b) a minimum clear height of 20 mm; and (c) the weir edge installed a minimum of 25 mm below the top of the fascia.	1.0	
Rainhead with— (a) a 75 mm diameter hole in the outward face of the rainhead; and (b) the centreline of the hole positioned 100 mm below the top of the fascia.	3.5	

Notes to Table 3.5.3.4b:

1. An end-stop weir is not suitable where the end-stop abuts a wall.
2. The rainhead should be detailed to avoid nuisance discharge from the overflow at rainfall intensities below the normal design level.

Explanatory information:

Stormwater drainage systems specified in the *Housing Provisions* are not designed to remove all water to an appropriate outfall during exceptionally heavy rain, particularly in tropical areas. Specifically, eaves gutter systems are designed to remove water arising from rainfall events with an *average recurrence interval* of 20 years provided they are not blocked. Accordingly, it is necessary to design and install the system to incorporate overflow measures so that when overflowing occurs, during a rainfall event with an *average recurrence interval* of up to 100 years, any water is directed away in a manner which ensures it does not pond against, enter or damage the building, even if the stormwater drainage system is blocked.

Insufficient and poorly located downpipes are a frequent cause of poor roof drainage system performance. The installation of downpipes, especially near valley gutters, is designed to ensure rainwater from areas on the roof that have concentrated water flows is adequately removed.

Particular consideration needs to be given to box gutters, valley gutters etc. located above the internal areas of a building.

There are several options available to designers using the requirements of the *Housing Provisions*. The designer will need to choose an overflow system that will cope with the rainfall intensity for the particular location. Consideration needs to be given to the total capacity of overflow measures on lower level roofs where overflow measures adopted for a higher roof catchment will result in overflow to a lower one. Overflow discharge onto lower roofs may also require consideration of sarking, flashing and other weatherproofing precautions to the lower roof area.

The acceptable overflow measures in Table 3.5.3.3a and Table 3.5.3.3b were calculated using the following formulas:

For continuous slots or rainhead

$$Q = C_d A \sqrt{2g h}$$

Where—

A = Area (m²)

C_d = Discharge coefficient = 0.61

g = Gravity = 9.81 m/s²

h = Effective head (m)

Q = Flow rate (m³/s)

For front face weir, end stop weir, inverted nozzle, front bead or controlled gap

$$Q = 0.67 C_d b \sqrt{2g h^{1.5}}$$

Where—

b = Width (m)

C_d = Discharge coefficient = 0.63

g = Gravity = 9.81 m/s²

h = Effective head (m)

Q = Flow rate (m³/s)

Part 3.5.4 Timber and composite wall cladding

Appropriate *Performance Requirements*

Where an alternative wall cladding is proposed as a *Performance Solution* to that described in [Part 3.5.4](#), that proposal must comply with—

- (a) [Performance Requirement P2.1.1](#); and
- (b) [Performance Requirement P2.2.2](#); and
- (c) the relevant *Performance Requirements* determined in accordance with [A2.2\(3\)](#) and [A2.4\(3\)](#) as applicable.

Explanatory information:

Masonry wall cladding

Masonry used as wall cladding, including masonry veneer, is not covered by [Part 3.5.4](#) but is covered by [Part 3.3](#).

Alternative wall cladding materials and systems

The Provisions of this Part and those of [Part 3.3](#) (Masonry) do not cover all of the wall cladding materials that may be used for a Class 1 or Class 10 building.

Wall cladding materials and systems not covered by the *Deemed-to-Satisfy Provisions* may be considered under a *Performance Solution* that complies with the relevant *Performance Requirements*.

One of the *Assessment Methods* that may be used to demonstrate compliance with the *Performance Requirements* is the use of documentary evidence in accordance with [Part A5](#).

Acceptable Construction Manuals

3.5.4.0 Application

[Performance Requirements P2.1.1](#) and [P2.2.2](#) are satisfied for autoclaved aerated concrete wall cladding if it is designed and constructed in accordance with AS 5146.1.

Acceptable Construction Practice

3.5.4.1 Application

Compliance with this acceptable construction practice satisfies [Performance Requirements P2.1.1](#) and [P2.2.2](#) for wall cladding provided—

- (a) It is installed in accordance with—
 - (i) [3.5.4.2](#) for timber cladding, including weatherboards and profiled boards; and
 - (ii) [3.5.4.3](#) for fibre-cement and hardboard wall cladding boards; and
 - (iii) [3.5.4.4](#) for fibre-cement, hardboard and plywood sheet wall cladding; and
- (b) fibre-cement sheet eaves where provided, are installed in accordance with [3.5.4.5](#); and
- (c) openings and penetrations in cladding are flashed in accordance with [3.5.4.6](#); and
- (d) the bottom surface of the cladding terminates in accordance with [3.5.4.7](#); and
- (e) parapets, where provided, are flashed in accordance with [3.5.4.8](#).

3.5.4.2 Timber wall cladding

Timber wall cladding must be installed as follows:

- (a) Splayed timber weatherboards must be fixed in accordance with [Figure 3.5.4.1](#) and with a lap not less than—
 - (i) 30 mm for hardwood, Cypress and treated pine; and
 - (ii) 20 mm for Western Red Cedar; and
 - (iii) 25 mm for Baltic Pine.

Roof and Wall Cladding

- (b) Profiled timber boards must be—
- (i) fixed in a horizontal, vertical or diagonal direction with the overlap and groove closely fitted, where provided; and
 - (ii) with tongue and groove profile, fixed with tongue edge up, where they are fixed in a horizontal or diagonal direction; and
 - (iii) where fixed in a vertical or diagonal direction, provided with a vapour permeable sarking complying with AS/NZS 4200.1 (see [Figure 3.5.4.2](#)) installed behind boards with—
 - (A) each adjoining sheet or roll being—
 - (aa) overlapped not less than 150 mm; or
 - (bb) taped together; and
 - (B) sarking fixed to supporting members at not more than 300 mm centres.
- (c) Splayed and profiled timber weatherboards must be fixed in accordance with [Table 3.5.4.1](#), with—
- (i) one fixing at each stud or equivalent framing member for splayed timber weatherboards; and
 - (ii) one fixing provided at each stud or equivalent framing member for profiled timber boards not more than 130 mm wide; and
 - (iii) two fixings provided at each stud or equivalent framing member for profiled timber board more than 130 mm wide; and
 - (iv) fixings located so that the fixing does not penetrate the tip or thinner edge of the board beneath.

Explanatory information:

[3.5.4.2\(c\)\(iv\)](#) ensures the fixing of the wall cladding does not split the wall cladding board below. For example, for a 30 mm lap, fix 35 mm from the butt or 5 mm above the corresponding overlapping board (see [Figure 3.5.4.1](#)).

Table 3.5.4.1 Fixing requirements—Splayed and profiled timber weatherboards

<i>Design wind speed</i>	<i>Maximum stud spacing (mm)</i>	<i>Minimum nominal stud fixings</i>
N1 — N3	600	Timber: 2.8 G or (8-18) S Steel: (8-18) S

Notes to [Table 3.5.4.1](#):

1. G = galvanised plain shank, threaded or equivalent nails.
 2. S = self embedding head or wafer head screw.
 3. Fasteners must penetrate not less than 30 mm into timber frames and not less than two full screw threads through steel frames.
 4. Wall cladding may be fixed through timber or metal battens attached to the wall frame in accordance with AS 1684.2, AS 1684.3, AS 1684.4 or NASH standard as appropriate (see fixing requirements for roof battens) so long as the minimum penetration into the wall frame is achieved.
 5. Steel framing members must have a base metal thickness (BMT) not less than 1.2 mm.
- (d) Fixings used for timber cladding must comply with the following:
- (i) Where fixings are punched or countersunk and filled prior to painting, fixings must be standard steel flat head nails or standard steel self embedding head screws.
 - (ii) Uncoated copper or steel fixings must not be used for Western Red Cedar (silicon bronze, monel metal, stainless steel or hot-dipped galvanised are suitable).
 - (iii) Where the building is located within 200 m of *breaking surf*, fixings must be—
 - (A) stainless steel when fixed into timber framing members; or
 - (B) hot-dipped galvanized (min 600 g/m²) when fixed into steel framing members.
 - (iv) In all other cases, fixings must be hot-dipped galvanised (min. 600 g/m²) flat head nails or hot dipped galvanised (min 600 g/m²) self embedding head or wafer head screws.

Explanatory information:

Roof and Wall Cladding

Timber cladding profiles

3.5.4.2 covers the following types of timber cladding profiles:

- Horizontal bevel-back
- Horizontal rebated bevel-back
- Horizontal rusticated
- Vertical and horizontal shiplap
- Tongue and groove

Machine and hand driven nails

Table 3.5.4.1 applies to both machine and hand driven nails.

3.5.4.3 Wall cladding boards

Wall cladding boards must—

- (a) for 7.5 mm (minimum) thick fibre-cement — comply with AS/NZS 2908.2 or ISO 8336; and
- (b) for 9.5 mm (minimum) thick hardboard — comply with AS/NZS 1859.4 for exterior grade; and
- (c) be fixed in accordance with Tables 3.5.4.2a and b with—
 - (i) one fixing provided at each stud or equivalent framing member for wall cladding boards not more than 130 mm wide; and
 - (ii) two fixings provided at each stud or equivalent framing member for wall cladding boards greater than 130 mm wide; and
 - (iii) fixings located along the studs at not more than 100 mm centres; and
 - (iv) fixings located so that they do not penetrate the tip or thinner edge of the board beneath; and
- (d) have a lap not less than—
 - (i) for 7.5 mm (minimum) thick fibre-cement—25mm; or
 - (ii) for 9.5 mm (minimum) thick hardboard—20 mm.

Explanatory information:

Where the wall cladding boards contain a shiplap joint as opposed to a lapped joint, 3.5.4.3(d) does not apply, and the joints between the boards are *required* to have the overlap and groove closely fitted.

Table 3.5.4.2a Fixing requirements—Minimum 7.5 mm thick fibre-cement wall cladding boards

<i>Design wind speed</i>	Maximum stud spacing (mm)	Minimum nominal stud fixings
N1 — N3	600	Timber: 2.8 GC Steel: (8-18) S

Notes to Table 3.5.4.2a:

1. GC = galvanised fibre-cement nail.
2. S = self embedding or wafer head screw.
3. Fasteners must penetrate not less than 30 mm into timber frames and not less than two full screw threads through steel frames.
4. Steel framing members must have a base metal thickness (BMT) not less than 1.2 mm.
5. Wall cladding may be fixed through timber or metal battens attached to the wall frame in accordance with AS 1684.2, AS 1684.3, AS 1684.4 or NASH standard as appropriate (see fixing requirements for roof battens) so long as the minimum penetration into the wall frame is achieved.

Table 3.5.4.2b Fixing requirements—Minimum 9.5 mm thick hardboard wall cladding boards

<i>Design wind speed</i>	Maximum stud spacing (mm)	Minimum nominal stud fixings
N1 — N3	600	Timber: 2.8 GC Steel: (8-18) S

Roof and Wall Cladding

Notes to Table 3.5.4.2b:

1. GC = galvanised fibre-cement nail.
2. S = self embedding or wafer head screw.
3. Fasteners must penetrate not less than 30 mm into timber frames and not less than two full screw threads through steel frames.
4. Steel framing members must have a base metal thickness (BMT) not less than 1.2 mm.
5. Wall cladding may be fixed through timber or metal battens attached to the wall frame in accordance with AS 1684.2, AS 1684.3, AS 1684.4 or NASH standard as appropriate (see fixing requirements for roof battens) so long as the minimum penetration into the wall frame is achieved.

Figure 3.5.4.1 Fixing of wall cladding

Diagram a Timber cladding

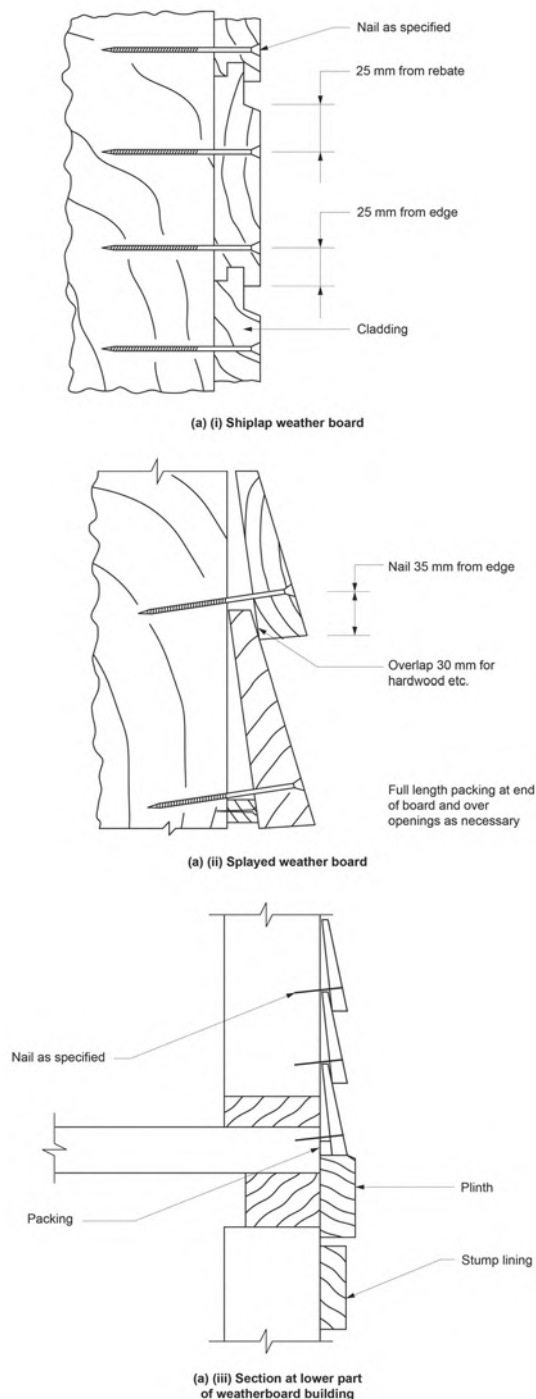

Roof and Wall Cladding



Figure 3.5.4.1 Fixing of wall cladding

Diagram b Wall Cladding Boards

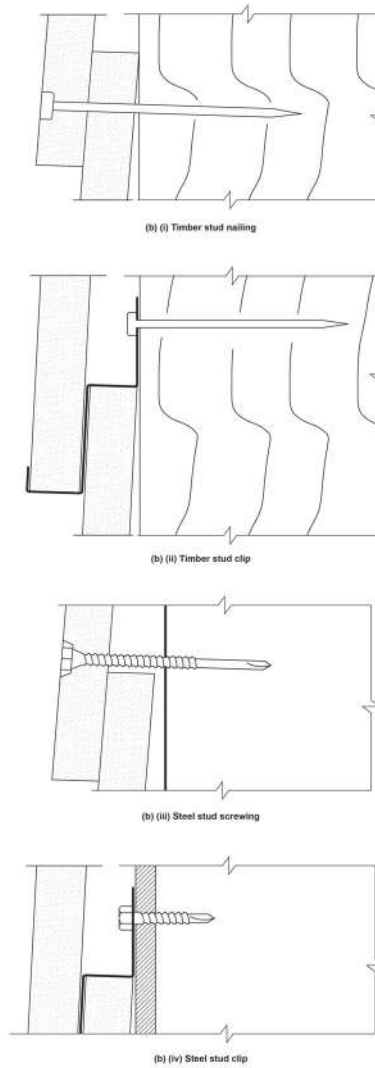

Roof and Wall Cladding

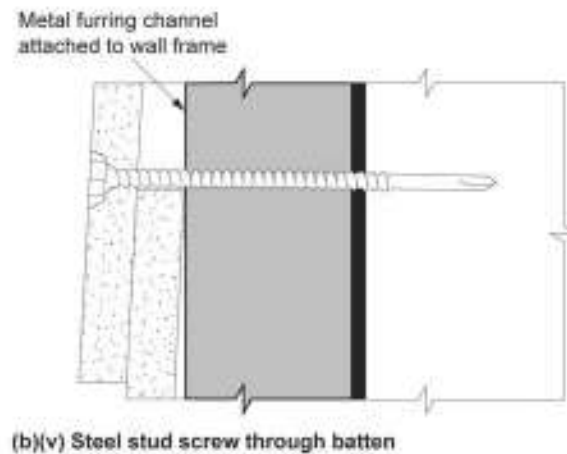
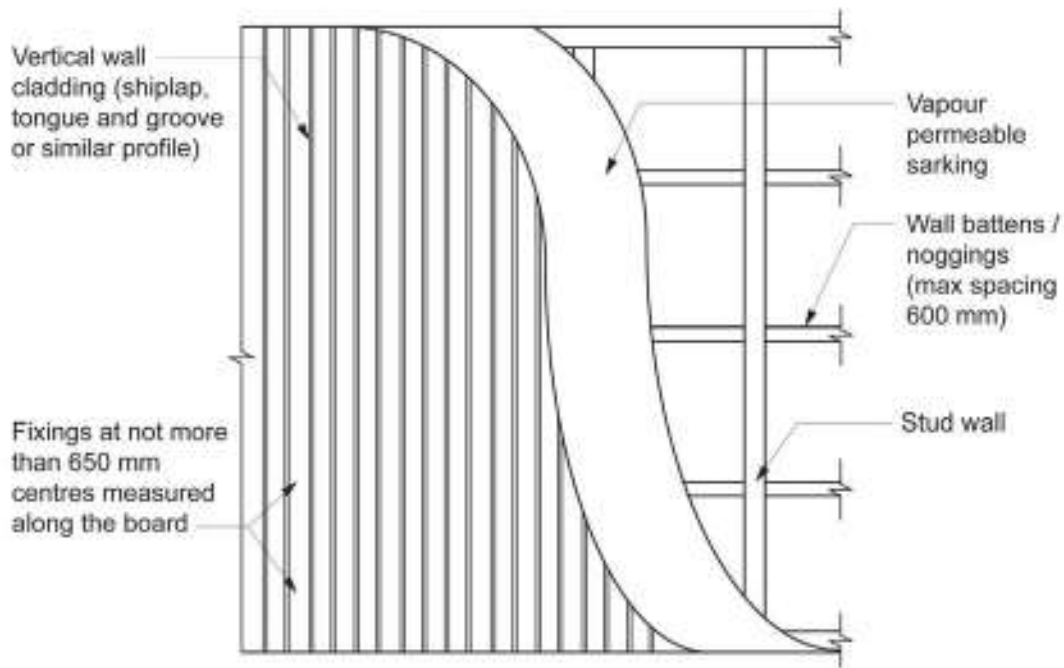

Figure 3.5.4.2 Fixing of vertical wall cladding



Note to Figure 3.5.4.2: For fixing of diagonal wall cladding, equivalent fixing details apply.

3.5.4.4 Sheet wall cladding

- (a) Fibre-cement sheet wall cladding must—
- (i) comply with AS/NZS 2908.2 or ISO 8336; and
 - (ii) be fixed in accordance with [Table 3.5.4.3](#).

Explanatory information:

Where sheet bracing is also acting as structural bracing, fixing requirements are listed in AS 1684 and NASH Standard – Residential and Low-Rise Steel Framing, Part 2.

Roof and Wall Cladding

Table 3.5.4.3 - Stud and fixing spacings for 6 mm fibre-cement sheet wall cladding

<i>Design wind speed</i>	Maximum stud spacing (mm)	Maximum nail spacing within 1.2 m of the external corners of the building (mm) ^{Note 1}	Maximum nail spacing elsewhere (mm) ^{Note 1}
N1	≤ 1.2 m of external building corners: 600 Elsewhere: 600	Body: 300 Edges: 200	Body: 300 Edges: 200
N2	≤ 1.2 m of external building corners: 600 Elsewhere: 600	Body: 200 Edges: 200	Body: 300 Edges: 200
N3	≤ 1.2 m of external building corners: 450 Elsewhere: 600	Body: 200 Edges: 200	Body: 200 Edges: 200

Notes to Table 3.5.4.3:

1. Maximum nail spacing using 2.8 mm fibre-cement nails.
 2. Fixings must be located not less than 50 mm from the edge of all corners.
 3. Fasteners must penetrate not less than 30 mm into a timber frame.
 4. Wall cladding may be fixed through timber or metal battens attached to the wall frame in accordance with AS 1684.2, AS 1684.3, AS 1684.4 or NASH standard as appropriate (see fixing requirements for roof battens) so long as the minimum penetration into the wall frame is achieved.
- (b) Hardboard sheet wall cladding must—
- (i) comply with AS/NZS 1859.4 for exterior grade; and
 - (ii) be fixed in accordance with Table 3.5.4.4.

Table 3.5.4.4 Stud and fixing spacings for 9.5 mm thick hardboard sheet wall cladding

<i>Design wind speed</i>	Maximum stud spacing (mm)	Maximum nail spacing within 1.2 m of the external corners of the building (mm) ^{Note 1}	Maximum nail spacing elsewhere (mm) ^{Note 1}
N1	600	Body: 300 Edges: 150	Body: 300 Edges: 150
N2	600	Body: 300 Edges: 150	Body: 300 Edges: 150
N3	600	Body: 300 Edges: 150	Body: 300 Edges: 150

Notes to Table 3.5.4.4:

1. Maximum nail spacing using 2.8 mm galvanised clouts or flat head nails.
 2. Fixings must be positioned a minimum of 12 mm from the edge of the sheet and not less than 50 mm from the edge of all corners.
 3. Fasteners must penetrate not less than 30 mm into the timber frame.
 4. Wall cladding may be fixed through timber or metal battens attached to the wall frame in accordance with AS 1684.2, AS 1684.3, AS 1684.4 or NASH standard as appropriate (see fixing requirements for roof battens) so long as the minimum penetration into the wall frame is achieved.
- (c) Structural plywood wall cladding must—
- (i) comply with AS/NZS 2269.0; and
 - (ii) be fixed in accordance with Table 3.5.4.5.

Roof and Wall Cladding

Table 3.5.4.5 Stud and fixing spacings for plywood wall cladding equal to or greater than 6.5 mm thick

<i>Design wind speed</i>	Maximum stud spacing (mm)	Maximum nail spacing within 1.2 m of the external corners of the building (mm) ^{Note 1}	Maximum nail spacing elsewhere (mm) ^{Note 1}
N1	600	Body: 200 Edges: 100	Body: 200 Edges: 150
N2	600	Body: 200 Edges: 100	Body: 200 Edges: 150
N3	600	Body: 150 Edges: 100	Body: 200 Edges: 150

Notes to Table 3.5.4.5:

1. Maximum nail spacing using 2.8 or 3.5 mm galvanised clouts or flat head nails.
2. Fixings must be positioned a minimum of 12 mm from the edge of the sheet and not less than 50 mm from the edge of all corners.
3. Fasteners must penetrate not less than 30 mm into the timber frame.
4. Wall cladding may be fixed through timber or metal battens attached to the wall frame in accordance with AS 1684.2, AS 1684.3, AS 1684.4 or NASH standard as appropriate (see fixing requirements for roof battens) so long as the minimum penetration into the wall frame is achieved.

3.5.4.5 Eaves and soffit linings

Where provided, external fibre-cement sheets and linings used as eaves and soffit linings must—

- (a) comply with AS/NZS 2908.2 or ISO 8336; and
- (b) be fixed in accordance with Table 3.5.4.6 and Figure 3.5.4.4 using—
 - (i) 2.8 × 30 mm fibre-cement nails; or
 - (ii) No. 8 wafer head screws (for 4.5 mm and 6 mm sheets only); or
 - (iii) No. 8 self embedding head screws (for 6 mm sheets only).

Table 3.5.4.6 Trimmer and fastener spacings for 4.5 and 6 mm fibre-cement eaves and soffit linings

Maximum eaves width	<i>Design wind speed</i>	Maximum trimmer spacings (mm)		Maximum fastener spacings (mm)	
		Within 1200 mm of the external corners of the building	Elsewhere	Within 1200 mm of the external corners of the building	Elsewhere
600	N1	600	900	200	300
	N2	600	800	200	300
	N3	500	700	200	300
1200	N1	600	750	200	300
	N2	600	700	200	300
	N3	500	650	200	300

Roof and Wall Cladding

Figure 3.5.4.4 Eaves trimmer detail

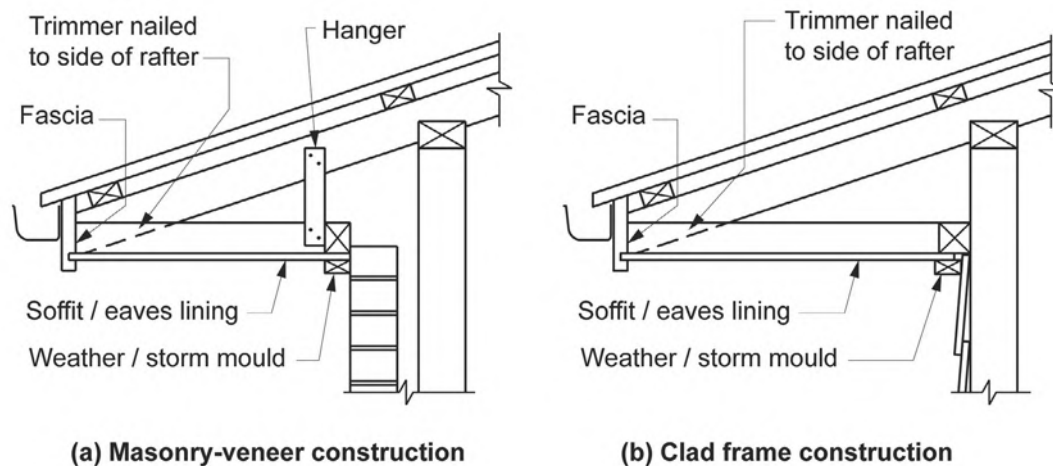

3.5.4.6 Flashings to wall openings

Openings in *external wall* cladding exposed to the weather must be flashed with materials complying with AS/NZS 2904 and in accordance with the following:

- (a) *Flashings* must be provided to bottom, tops and sides of openings, except as permitted by (d), and must be installed so that the *flashing*—
 - (i) extends not less than 110 mm beyond the reveals on each side of the opening where practicable; and
 - (ii) is attached to the *window* and wall framing; and
 - (iii) at the top and bottom of the opening, drains to the outside face of the wall or cladding.
- (b) Joins in the *flashing* must—
 - (i) overlap by not less than 75 mm in the direction of flow; and
 - (ii) be securely fastened at intervals of not more than 40 mm; and
 - (iii) have sealant installed between laps.
- (c) The method of *flashing* must be suitable for the framing and cladding used and any reveal for the *window* or door system or any architrave or finishing trims that may be installed.
- (d) The top of an opening need not be flashed where it is adequately protected by an eave of a width more than 3 times the height of the cladding above the opening (See Figure 3.5.4.5).
- (e) *Flashings* must be securely fixed at least 25 mm under the cladding and extend over the ends and edges of the framing of the opening.

Explanatory information:

3.5.4.6(a)(i) applies 'where practicable' because it is often impractical to extend the *flashing* 110 mm beyond the reveal; for example, where openings are positioned adjacent to a corner or where two *windows* are within 110 mm of each other. In such cases consideration should be given to ensure the *flashing* prevents the penetration of water into the *external wall*.

Figure 3.5.4.5 Weather protection of openings

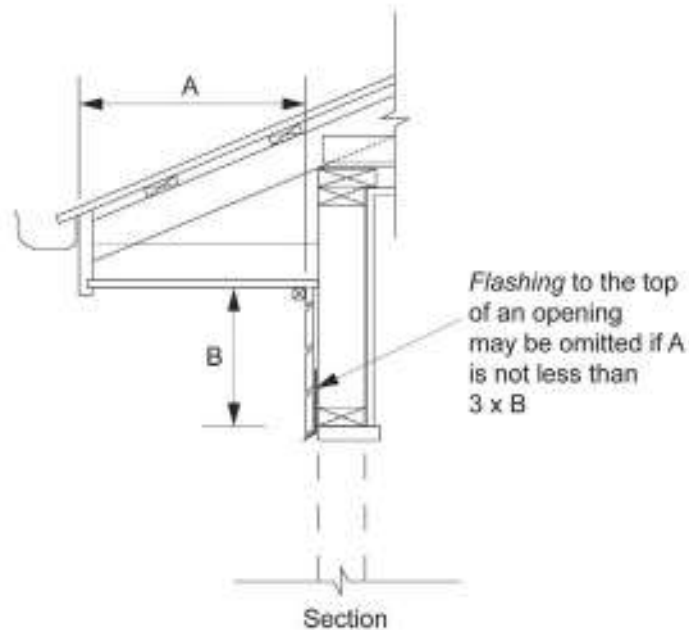

3.5.4.7 Clearance between cladding and ground

- (a) The minimum clearance from the bottom of the wall cladding to the adjoining finished ground level must be—
- (i) 100 mm in *low rainfall intensity areas* or sandy, well-drained areas; or
 - (ii) 50 mm above impermeable (paved or concreted) areas that slope away from the building in accordance with 3.1.3.3(a); or
 - (iii) 150 mm in any other case.
- (b) Wall cladding must extend a minimum of 50 mm below the bearer or lowest horizontal part of the suspended floor framing.

Explanatory information:

The 3.5.4.7 clearances may also be subject to other requirements for drainage in Part 3.1.3, clearances for inspection zones for termite management in Part 3.1.4 and screening and sealing of gap requirements for construction in bushfire prone areas in Part 3.10.5, where appropriate.

3.5.4.8 Parapet cappings

Where a wall cladding is used to form a parapet wall, the cladding must be attached to a supporting frame and have a capping installed that complies with the following:

- (a) Cappings must—
- (i) be purpose made, machine-folded sheet metal or equivalent sections of a material compatible with all up and downstream metal roof covering materials in accordance with 3.5.1.2(b); and
 - (ii) extend not less than 50 mm down the sides of the parapet; and
 - (iii) be separated from the supporting framing by a vapour permeable sarking installed in accordance with (f); and
 - (iv) be fixed with either self drilling screws or rivets with rubber washers at intervals of not more than 500 mm that do not penetrate the top of cappings, except at joints and corners.

Roof and Wall Cladding

- (b) The top of the capping must slope a minimum of 5 degrees.
- (c) Joints in cappings must—
 - (i) overlap by not less than 50 mm in the direction of flow; and
 - (ii) be securely fastened at intervals of not more than 40 mm; and
 - (iii) have sealant installed between laps.
- (d) Fixing for cappings must be compatible with the capping material.
- (e) Lead cappings must not be used with prepainted steel or zinc/aluminium steel or on any roof if the roof is part of a potable (drinking) water catchment area.
- (f) Sarking must comply with AS/NZS 4200.1 and be installed behind all wall cladding where parapets are installed, with—
 - (i) each adjoining sheet or roll being—
 - (A) overlapped not less than 150 mm; or
 - (B) taped together; and
 - (ii) sarking fixed to supporting members at not more than 300 mm centres.

Explanatory information:

For the purposes of 3.5.4.8(f), sarking is *required* to be installed to the whole *external wall* which contains the parapet, and extend to the top and back of the parapet. A gap should be provided between the sarking and the parapet capping to help control *condensation*.

Part 3.5.5 Metal wall cladding

Appropriate *Performance Requirements*

Where an alternative metal wall cladding is proposed as a *Performance Solution* to that described in [Part 3.5.5](#), that proposal must comply with—

- (a) *Performance Requirement P2.1.1*; and
- (b) *Performance Requirement P2.2.2*; and
- (c) the relevant *Performance Requirements* determined in accordance with [A2.2\(3\)](#) and [A2.4\(3\)](#) as applicable.

Acceptable Construction Manuals

3.5.5.0 Application

Performance Requirements P2.1.1 and *P2.2.2* are satisfied for a metal wall cladding if it is designed and constructed in accordance with AS 1562.1.

Glazing

Part 3.6

Glazing

Part 3.6 Glazing

Part 3.6 Glazing

Acceptable Construction Manuals

3.6.0 Application

Acceptable Construction Practice

3.6.1 Application

3.6.2 Glazing sizes and installation

3.6.3 Fully framed glazing installed in perimeter of buildings

3.6.4 Human impact safety requirements

3.6.4.1 Doors

3.6.4.2 Door side panels

3.6.4.3 Full height framed glazed panels

3.6.4.4 Glazed panels, other than doors or side panels, on the perimeter of rooms

3.6.4.5 Bathroom, ensuite and spa room glazing

3.6.4.6 Visibility of glazing

Part 3.6 Glazing

Appropriate *Performance Requirements*

Where an alternative glazing system is proposed as a *Performance Solution* to that described in [Part 3.6](#), that proposal must comply with—

- (a) *Performance Requirement P2.1.1*; and
- (b) *Performance Requirement P2.2.2*; and
- (c) the relevant *Performance Requirements* determined in accordance with [A2.2\(3\)](#) and [A2.4\(3\)](#) as applicable.

Acceptable Construction Manuals

3.6.0 Application

- (a) *Performance Requirements P2.1.1* and *P2.2.2* are satisfied for glazing and *windows* if designed and constructed in accordance with AS 2047 for the following glazed assemblies in an *external wall*:
 - (i) *Windows* excluding those listed in (b).
 - (ii) Sliding and swinging glazed doors with a frame, including french and bi-fold doors with a frame.
 - (iii) Adjustable louvres.
 - (iv) *Window* walls with one piece framing.
- (b) *Performance Requirement P2.1.1* is satisfied for glazing if designed and constructed in accordance with AS 1288 for all glazed assemblies not covered by (a) and the following glazed assemblies:
 - (i) All glazed assemblies not in an *external wall*.
 - (ii) Revolving doors.
 - (iii) Fixed louvres.
 - (iv) Skylights, roof lights and *windows* in other than the vertical plane.
 - (v) Sliding and swinging doors without a frame.
 - (vi) *Windows* constructed on site and architectural one-off *windows*, which are not design tested in accordance with AS 2047.
 - (vii) Second-hand *windows*, re-used *windows* and recycled *windows*.
 - (viii) Heritage *windows*.
 - (ix) Glazing used in balustrades and sloping overhead glazing.

Explanatory information:

1. The reference to heritage *windows* in [3.6.0\(b\)\(viii\)](#) is intended to apply to *windows* in heritage buildings. The method of determining a heritage building is normally covered by the relevant State or Territory authority.
2. When satisfying *Performance Requirement P2.2.2* “Weatherproofing”, [Part 3.6](#) only contains the acceptable construction manual AS 2047 for *windows*. If AS 1288 is used as an acceptable construction manual for glazing in an *external wall*, it is still necessary to satisfy *P2.2.2*.

Acceptable Construction Practice

3.6.1 Application

Compliance with this acceptable construction practice satisfies *Performance Requirement P2.1.1* for glazing, provided—

- (a) the building is located in an area with a *design wind speed* of not more than N3; and

Explanatory information:

1. Information on *design wind speed* for particular areas may be available from the *appropriate authority*.

Glazing

2. For glazing in *high wind areas* refer to [Part 3.0](#).
- (b) glass is of a type recognised by AS 1288; and
 - (c) safety glazing is legibly marked in accordance with AS 1288; and
 - (d) glazing used in barriers complies with AS 1288; and
 - (e) safety glazing is made visible in accordance with [3.6.4.6](#); and
 - (f) the glazing is not for the following assemblies in an *external wall*:
 - (i) *Windows* excluding those listed in (g).
 - (ii) Sliding and swinging doors with a frame, including french and bi-fold doors with a frame.
 - (iii) Adjustable louvres.
 - (iv) *Window* walls with one piece framing; and
 - (g) the glazing is for all assemblies not covered by (f) and the following glazed assemblies:
 - (i) All glazed assemblies not in an *external wall*.
 - (ii) Revolving doors.
 - (iii) Fixed louvres.
 - (iv) Skylights, roof lights and *windows* in other than the vertical plane.
 - (v) Sliding and swinging doors without a frame.
 - (vi) *Windows* constructed on site and architectural one-off *windows*, which are not design tested in accordance with AS 2047.
 - (vii) Second-hand *windows*, re-used *windows* and recycled *windows*.
 - (viii) Heritage *windows*.

Explanatory information:

This acceptable construction practice applies to the selection of glass only and does not include the installation of *windows* or framed glazed doors. This is due to *window* systems relying on the design and testing of structural system members to withstand wind loads (e.g. mullions, transoms, and meeting rails and stiles) and the perimeter frame design, sealants and gaskets to resist water penetration.

3.6.2 Glazing sizes and installation

Glazing used in buildings must comply with the following:

- (a) Glazing used in the *perimeter of buildings* and supported on all sides must comply with the appropriate provisions listed in [3.6.3](#).
- (b) Glazing used in areas where the potential for human impact could occur must comply with the appropriate provisions listed in [3.6.4](#).
- (c) For 3 mm monolithic annealed glass, the maximum area must not be more than 0.85 m².
- (d) For 3 mm annealed glass used in Insulated Glass Units (IGU), the maximum area must not be more than 1.36 m².

Explanatory information:

An Insulated Glass Unit consists of two or more panes of glass spaced apart and factory sealed with dry air or special gases in the cavity. The term is often abbreviated to IGU.

- (e) All exposed edges must have sharp edges removed.

Explanatory information:

The selection of glass thickness relies not just on limit state wind loads but on a number of geometric criteria that include the influence of aspect ratio and slenderness factors. These factors are taken into account in [Tables 3.6.1](#) to [3.6.3](#).

3.6.3 Fully framed glazing installed in perimeter of buildings

Fully framed (supported on all sides) ordinary annealed glass (including annealed patterned glass) installed in the *perimeter*

Glazing

of buildings must comply with—

- (a) if the building is located in an area with a wind class not exceeding N1 – [Table 3.6.1](#); or
- (b) if the building is located in an area with a wind class not exceeding N2 – [Table 3.6.2](#); or
- (c) if the building is located in an area with a wind class not exceeding N3 – [Table 3.6.3](#).

Explanatory information:

1. For other types of perimeter glazing including toughened, wired, laminated and unframed glazing refer to AS 1288.
2. For ordinary annealed patterned glass thickness measurement refer to AS 1288.

Table 3.6.1 Glass thickness for wind class not exceeding N1: ordinary annealed glass (mm)

	Edge 1 300 mm	Edge 1 450 mm	Edge 1 600 mm	Edge 1 750 mm	Edge 1 900 mm	Edge 1 1050 mm	Edge 1 1200 mm	Edge 1 1350 mm	Edge 1 1500 mm	Edge 1 1650 mm
Edge 2 300 mm	3	3	3	3	3	3	3	3	3	3
Edge 2 450 mm	3	3	3	3	3	3	3	3	3	3
Edge 2 600 mm	3	3	3	3	3	3	3	3	4	4
Edge 2 750 mm	3	3	3	3	3	3	4	4	4	4
Edge 2 900 mm	3	3	3	3	3	4	4	4	4	4
Edge 2 1050 mm	3	3	3	3	4	4	4	4	4	4
Edge 2 1200 mm	3	3	3	4	4	4	4	4	4	4
Edge 2 1350 mm	3	3	3	4	4	4	4	4	4	4
Edge 2 1500 mm	3	3	4	4	4	4	4	4	4	4
Edge 2 1650 mm	3	3	4	4	4	4	4	4	4	4
Edge 2 1800 mm	3	3	4	4	4	4	4	4	4	4
Edge 2 1950 mm	3	4	4	4	4	4	4	4	4	4
Edge 2 2100 mm	3	4	4	4	4	4	4	4	4	4
Edge 2 2250 mm	3	4	4	4	4	4	4	4	4	4
Edge 2 2400 mm	3	4	4	4	4	4	4	4	4	4
Edge 2 2550 mm	3	4	4	4	4	4	4	4	4	4
Edge 2 2700 mm	3	4	4	4	4	4	4	4	4	4

Glazing

Table 3.6.2 Glass thickness for wind class not exceeding N2: ordinary annealed glass (mm)

	Edge 1 300 mm	Edge 1 450 mm	Edge 1 600 mm	Edge 1 750 mm	Edge 1 900 mm	Edge 1 1050 mm	Edge 1 1200 mm	Edge 1 1350 mm	Edge 1 1500 mm	Edge 1 1650 mm
Edge 2 300 mm	3	3	3	3	3	3	3	3	3	3
Edge 2 450 mm	3	3	3	3	3	3	3	3	3	3
Edge 2 600 mm	3	3	3	3	3	3	3	3	4	4
Edge 2 750 mm	3	3	3	3	3	3	4	4	4	4
Edge 2 900 mm	3	3	3	3	3	4	4	4	4	4
Edge 2 1050 mm	3	3	3	3	4	4	4	4	4	4
Edge 2 1200 mm	3	3	3	4	4	4	4	4	4	4
Edge 2 1350 mm	3	3	3	4	4	4	4	4	4	4
Edge 2 1500 mm	3	3	4	4	4	4	4	4	4	4
Edge 2 1650 mm	3	3	4	4	4	4	4	4	4	4
Edge 2 1800 mm	3	3	4	4	4	4	4	4	4	4
Edge 2 1950 mm	3	4	4	4	4	4	4	4	4	4
Edge 2 2100 mm	3	4	4	4	4	4	4	4	4	5
Edge 2 2250 mm	3	4	4	4	4	4	4	4	4	5
Edge 2 2400 mm	3	4	4	4	4	4	4	4	4	5
Edge 2 2550 mm	3	4	4	4	4	4	4	4	5	5
Edge 2 2700 mm	3	4	4	4	4	4	4	4	5	5

Table 3.6.3 Glass thickness for wind class not exceeding N3: ordinary annealed glass (mm)

	Edge 1 300 mm	Edge 1 450 mm	Edge 1 600 mm	Edge 1 750 mm	Edge 1 900 mm	Edge 1 1050 mm	Edge 1 1200 mm	Edge 1 1350 mm	Edge 1 1500 mm	Edge 1 1650 mm
Edge 2 300 mm	3	3	3	3	3	3	3	3	3	3
Edge 2 450 mm	3	3	3	3	3	3	3	3	3	3
Edge 2 600 mm	3	3	3	3	3	3	3	3	4	4
Edge 2	3	3	3	3	3	3	4	4	4	4

Glazing

	Edge 1 300 mm	Edge 1 450 mm	Edge 1 600 mm	Edge 1 750 mm	Edge 1 900 mm	Edge 1 1050 mm	Edge 1 1200 mm	Edge 1 1350 mm	Edge 1 1500 mm	Edge 1 1650 mm
750 mm										
Edge 2 900 mm	3	3	3	3	3	4	4	4	4	4
Edge 2 1050 mm	3	3	3	3	4	4	4	4	4	4
Edge 2 1200 mm	3	3	3	4	4	4	4	4	4	4
Edge 2 1350 mm	3	3	3	4	4	4	4	4	4	5
Edge 2 1500 mm	3	3	4	4	4	4	4	4	5	5
Edge 2 1650 mm	3	3	4	4	4	4	4	5	5	5
Edge 2 1800 mm	3	3	4	4	4	4	4	5	5	5
Edge 2 1950 mm	3	4	4	4	4	4	5	5	5	5
Edge 2 2100 mm	3	4	4	4	4	4	5	5	5	6
Edge 2 2250 mm	3	4	4	4	4	4	5	5	5	6
Edge 2 2400 mm	3	4	4	4	4	4	5	5	6	6
Edge 2 2550 mm	3	4	4	4	5	5	5	5	6	6
Edge 2 2700 mm	3	4	4	4	5	5	5	5	6	6

3.6.4 Human impact safety requirements

The thickness and type of glazing installed in areas of a building that have a high potential for human impact (an area of a building frequented by the occupants during everyday activities in which a person could fall into or against the glazed panel) must comply as follows:

- (a) Doors — in accordance with [3.6.4.1](#).
- (b) Door side panels — in accordance with [3.6.4.2](#).
- (c) Full height glass panels — in accordance with [3.6.4.3](#).
- (d) Glazed panels, other than doors or side panels, on the perimeter of rooms — in accordance with [3.6.4.4](#).
- (e) Bathrooms, ensuite and spa room glazing — in accordance with [3.6.4.5](#).
- (f) Visibility of glazing — in accordance with [3.6.4.6](#).

3.6.4.1 Doors

Glass in doors must be Grade A safety glazing material in accordance with [Table 3.6.5](#) and [Figure 3.6.1](#), except that—

- (a) unframed doors, other than those incorporated in shower screens or bath enclosures, must be glazed with toughened safety glass with a minimum nominal thickness of 10 mm or laminated toughened safety glass with a minimum total thickness of 10 mm; and
- (b) individual pieces of ordinary annealed glass incorporated in leadlights may be used, to a maximum area of 0.05 m² with a minimum nominal thickness of 3 mm; and

Glazing

Explanatory information:

Larger areas of ordinary annealed glass in leadlights are not permitted regardless of glass thickness.

- (c) for annealed and annealed decorated glass panels in doors—
 - (i) for 3 mm and 4 mm annealed glass, the maximum area must not be more than 0.1 m² with a maximum panel width of 125 mm; and
 - (ii) for 5 mm and 6 mm annealed glass, the maximum area must not be more than 0.26 m² with a maximum panel width of 300 mm; and
- (d) for annealed glass in fully framed panels with a thickness of 10 mm or more, with or without bevelled edges, the maximum area must not be more than 0.5 m²; and
- (e) doors in bathrooms, ensuites and spa rooms must be glazed in accordance with 3.6.4.5.

3.6.4.2 Door side panels

- (a) All framed glass (except leadlight panels) in side panels with their nearest vertical sight line less than 300 mm from the nearest edge of the doorway opening must be Grade A safety glazing material in accordance with Table 3.6.5 and Figure 3.6.1, except that—
 - (i) where the lowest visible sight line is 1.2 m or more above the highest abutting finished floor level, ordinary annealed glass in accordance with Table 3.6.4 may be used; or
 - (ii) where the lowest visible sight line is less than 1.2 m above the highest abutting finished floor level, ordinary annealed glass in accordance with Table 3.6.4, with an area of not more than 0.5 m², may be used; or
 - (iii) where the side panel consists of glass louvres with exposed edges or where the louvres are installed less than 500 mm above the highest abutting finished floor level—
 - (A) for blade widths not more than 230 mm with blade lengths not more than 1 m, Grade A toughened safety glazing not less than 5 mm thick must be used; and
 - (B) for blade widths more than 230 mm, Grade A toughened safety glazing not less than 10 mm thick must be used.
- (b) Framed glass panels with the nearest vertical sight line not less than 300 mm from the nearest edge of the door opening are not considered to be side panels for the purposes of (a).

Table 3.6.4 Maximum areas of ordinary annealed glass in side panels

Minimum nominal thickness (mm)	Maximum area of pane (m ²)
3	0.8
4	1.4
5	2.2
6	3.3

3.6.4.3 Full height framed glazed panels

- (a) A glazed panel located in a building so that it is capable of being mistaken for an *unobstructed opening* must be glazed with—
 - (i) Grade A safety glazing material in accordance with Table 3.6.5; or
 - (ii) ordinary annealed glass complying with Table 3.6.5 provided the glazed area is not more than 0.9 m².
- (b) Glazed panels are not considered an *unobstructed opening* where any of the following apply:
 - (i) The clear opening width is not more than 500 mm.
 - (ii) The lowest sight line of the opening is not less than 500 mm above the highest abutting finished floor level.
 - (iii) The glass is made apparent by means of transoms, colonial bars, other components of the glazing system, permanent motifs or other decorative treatment on or etched into the glass, of sufficient magnitude to be readily apparent, or the glass is opaquely coloured or patterned to indicate its presence.
 - (iv) A chair rail or handrail not less than 40 mm thick, or the like, is provided at a height of 865 mm above the adjoining ground level.

Glazing

- (v) The difference in floor level on either side of the panel is greater than 500 mm.

Figure 3.6.1 Identification of glazing requirements for doors and side panels

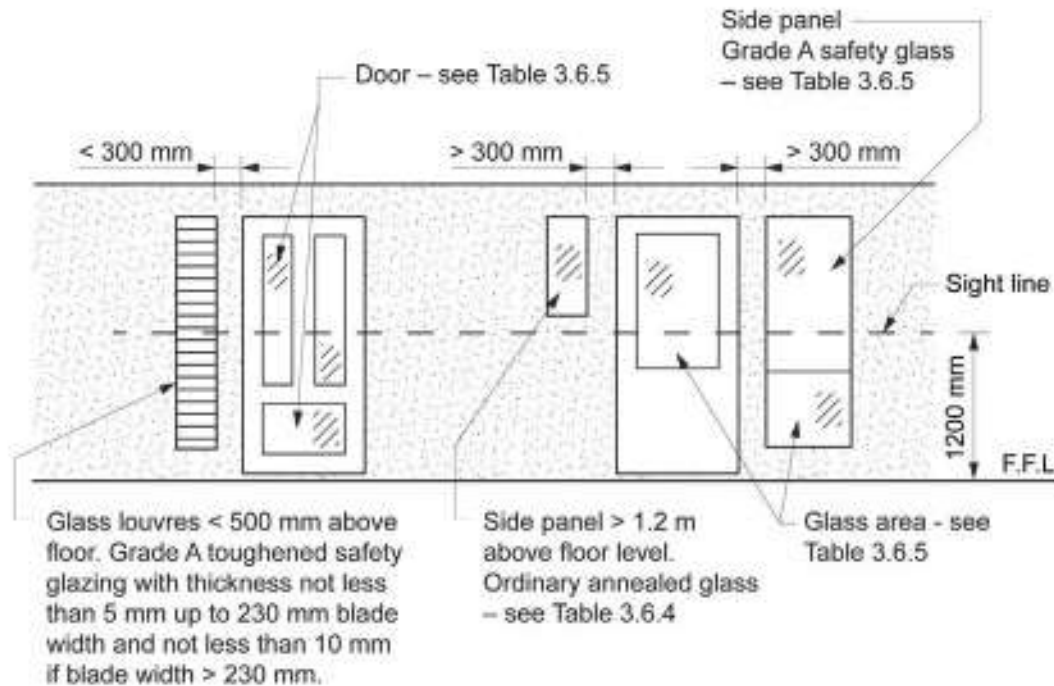

Table 3.6.5 Maximum areas of glazing material for framed glass doors, framed glass side panels, and other framed glazed panels

Type of glass	Minimum nominal thickness (mm)	Maximum area of pane (m ²)
Patterned or clear ordinary annealed glass	5	0.3
Patterned or clear ordinary annealed glass	6	0.9
Grade A toughened and toughened laminated safety glass	3	1
Grade A toughened and toughened laminated safety glass	4	2
Grade A toughened and toughened laminated safety glass	5	3
Grade A toughened and toughened laminated safety glass	6	4
Grade A laminated safety glass	5.38	2.2
Grade A laminated safety glass	6.38	3
Grade A laminated safety glass	8.38	5

3.6.4.4 Glazed panels, other than doors or side panels, on the perimeter of rooms

All framed glazing where the lowest sight line of the glazing panel is less than 500 mm from the highest abutting finished floor level (see [Figure 3.6.2](#)) must be—

- Grade A safety glazing material in accordance with [Table 3.6.5](#); or
- ordinary annealed glass not less than 5 mm nominal thickness provided that the area of the glazing panel is not more than 1.2 m².

Glazing

Figure 3.6.2 Identification of glazing requirements for glazed panels

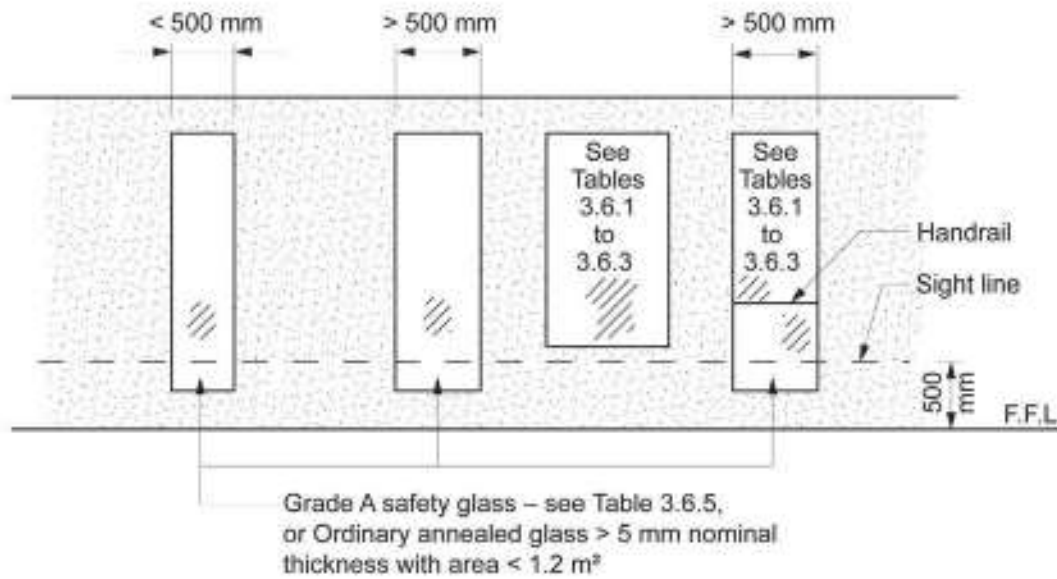

3.6.4.5 Bathroom, ensuite and spa room glazing

- (a) All glazing in bathrooms, ensuites, spa rooms or the like, including shower doors, shower screens, bath enclosures, and associated *windows*, where the lowest sight line is less than 2.0 m above the highest abutting finished level of the floor, bottom of the bath, or shower base, must—
- (i) for framed panels, be glazed with—
 - (A) Grade A safety glazing material in accordance with [Table 3.6.5](#); or
 - (B) Grade B safety glazing material in accordance with [Table 3.6.6](#) (see also [Figure 3.6.3](#)); or
 - (ii) for panels or doors with any edge exposed, be toughened safety glass in accordance with [Table 3.6.5](#) with a minimum nominal thickness of 6 mm.
- (b) *Windows* referred to in (a), may incorporate annealed glass panels of not less than 4 mm thickness, provided that they are not more than 0.1 m² in area.
- (c) Ordinary annealed glass, including mirror, may be used provided a fixed vanity or bench with a height of not less than 760 mm, depth of not less than 300 mm and extending the full width of the glass or mirror is located in front of the glass or mirror.

Explanatory information:

Care should be taken when using showers fitted with safety wired glass, safety organic-coated glass, and laminated safety glass products that are liable to damage from thermal shock. Thermal shock occurs from hot water from the shower hitting the shower screen during cold weather.

Table 3.6.6 Maximum areas of grade B safety glazing materials for shower doors, shower screens and bath enclosures

Type of glass	Standard nominal thickness (mm)	Maximum area of pane (m ²)	Area (Figure 3.6.3)
Safety wired glass	Greater than or equal to 6	2.5	A, B, C
Safety organic coated glass	3	1	A, B, C, D
Safety organic coated glass	4	1.5	A, B, C, D
Safety organic coated glass	5	2	A, B, C, D
Safety organic coated glass	Greater than or equal to 6	3	A, B, C, D

Glazing

Figure 3.6.3 Identification of glazing requirements for bathrooms, ensuites and spa rooms

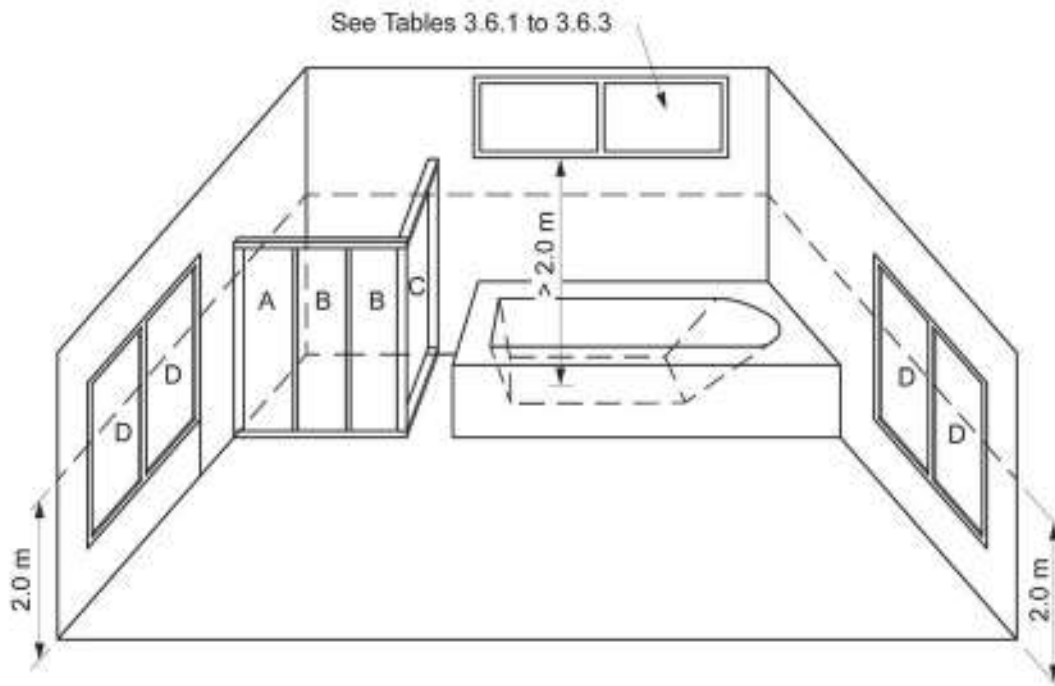

3.6.4.6 Visibility of glazing

- (a) If the presence of glazing in a door, side panel or panel capable of being mistaken for a doorway or opening is not made apparent in accordance with 3.6.4.3(b)(iii), the glass must be marked to make it readily visible in accordance with (b).
- (b) Marking must be in the form of an opaque band not less than 20 mm in height located so that—
- (i) the upper edge is not less than 700 mm above the floor; and
 - (ii) the lower edge is not more than 1.2 m above the floor.

Explanatory information:

1. Making the glass visible by marking is not a substitute for the use of safety glazing in accordance with this Part.
 2. A broken line or patterns may be an acceptable form of marking provided it meets the criteria set out in 3.6.4.6(b).
- (c) A band or marking is not *required* where any of the following applies:
- (i) The height of the glazing is not more than 1 m in any part.
 - (ii) The width of the glazing panel is not more than 500 mm in any part.
 - (iii) There is no glazing within 700 mm of the floor.
 - (iv) The glazing is provided with not less than one fixed glazing bar which must—
 - (A) be firmly attached to the styles to locate and protect each face of the glass; and
 - (B) be located with its upper edge not less than 500 mm and its bottom edge not more than 1 m above the floor; and
 - (C) have a face width not less than 40 mm.

Part **3.7**

Fire Safety

- Part 3.7.1** **Fire properties for materials and construction**
- Part 3.7.2** **Fire separation of external walls**
- Part 3.7.3** **Fire protection of separating walls and floors**
- Part 3.7.4** **Fire separation of garage top dwellings**
- Part 3.7.5** **Smoke alarms and evacuation lighting**

Part 3.7 Fire Safety

Part 3.7.1 Fire properties for materials and construction

Acceptable Construction Practice

3.7.1.1 General concession — non-combustible materials

3.7.1.2 Fire hazard properties

Part 3.7.2 Fire separation of external walls

Acceptable Construction Practice

3.7.2.1 Application

3.7.2.2 External walls of Class 1 buildings

3.7.2.3 Measurement of distances

3.7.2.4 Construction of external walls

3.7.2.5 Class 10a buildings

3.7.2.6 Open carports

3.7.2.7 Allowable encroachments

3.7.2.8 Roof lights

Part 3.7.3 Fire protection of separating walls and floors

Acceptable Construction Practice

3.7.3.1 Application

3.7.3.2 Separating walls

3.7.3.3 Services in separating walls

3.7.3.4 Roof lights

3.7.3.5 Horizontal projections

Part 3.7.4 Fire separation of garage top dwellings

Acceptable Construction Practice

3.7.4.1 Application

3.7.4.2 Walls requiring protection

3.7.4.3 Separating floors

Part 3.7.5 Smoke alarms and evacuation lighting

Acceptable Construction Practice

3.7.5.1 Application

3.7.5.2 Smoke alarm requirements

3.7.5.3 Location — Class 1a buildings

3.7.5.4 Location — Class 1b buildings

3.7.5.5 Installation of smoke alarms

3.7.5.6 Lighting to assist evacuation — Class 1b buildings

Part 3.7.1 Fire properties for materials and construction

Appropriate *Performance Requirements*

Where an alternative fire property for materials and construction is proposed as a *Performance Solution* to that described in [Part 3.7.1](#), that proposal must comply with—

- (a) *Performance Requirement P2.3.1*; and
- (b) the relevant *Performance Requirements* determined in accordance with [A2.2\(3\)](#) and [A2.4\(3\)](#) as applicable.

Acceptable Construction Practice

3.7.1.1 General concession — non-combustible materials

The following materials, though *combustible* or containing *combustible* fibres, may be used wherever a *non-combustible* material is required in the *Housing Provisions*:

- (a) Plasterboard.
- (b) Perforated gypsum lath with a normal paper finish.
- (c) Fibrous-plaster sheet.
- (d) Fibre-reinforced cement sheeting.
- (e) Pre-finished metal sheeting having a *combustible* surface finish not exceeding 1 mm thick and where the *Spread-of-Flame Index* of the product is not more than 0.
- (f) *Sarking-type materials* that do not exceed 1 mm in thickness and have a *flammability index* not greater than 5.
- (g) Bonded laminated materials where—
 - (i) each lamina, including any core, is *non-combustible*; and
 - (ii) each adhesive layer does not exceed 1 mm in thickness and the total thickness of the adhesive layers does not exceed 2 mm; and
 - (iii) the *Spread-of-Flame Index* and the *Smoke-Developed Index* of the bonded laminated material as a whole do not exceed 0 and 3 respectively.

3.7.1.2 Fire hazard properties

The fire hazard properties of materials used in a Class 1 building, including floor or ceiling spaces common with a Class 10 building, must comply with the following:

- (a) *Sarking-type materials* used in the roof must have a *flammability index* not greater than 5.
- (b) Flexible ductwork used for the transfer of products initiating from a heat source that contains a flame must comply with the fire hazard properties set out in AS 4254.1.

Part 3.7.2 Fire separation of external walls

Appropriate *Performance Requirements*

Where an alternative fire separation design is proposed as a *Performance Solution* to that described in [Part 3.7.2](#), that proposal must comply with—

- (a) *Performance Requirement P2.3.1*; and
- (b) the relevant *Performance Requirements* determined in accordance with [A2.2\(3\)](#) and [A2.4\(3\)](#) as applicable.

Acceptable Construction Practice

3.7.2.1 Application

Compliance with this acceptable construction practice satisfies *Performance Requirement P2.3.1* for fire separation.

3.7.2.2 External walls of Class 1 buildings

An *external wall* of a Class 1 building, and any openings in that wall, must comply with [3.7.2.4](#) if the wall is less than—

- (a) 900 mm from an allotment boundary other than the boundary adjoining a road alignment or other public space; or
- (b) 1.8 m from another building on the same allotment other than a Class 10 building associated with the Class 1 building or a detached part of the same Class 1 building.

State and Territory Variations

In South Australia delete [3.7.2.2\(b\)](#) and insert SA [3.7.2.2\(b\)](#) and (c) as follows:

- (b) 1.8 m from another building on the same allotment other than an appurtenant Class 10 building associated with the Class 10 building or a detached part of the same Class 1 building; or
- (c) 3 m from a *brush fence*.

3.7.2.3 Measurement of distances

- (a) The distance from any point on an *external wall* of a building to an allotment boundary or another building is the distance to that point measured along a line at right angles from the allotment boundary or *external wall* of the other building which intersects that point without being obstructed by a wall complying with [3.7.2.4](#).
- (b) Where a wall within a specified distance is *required* to comply with [3.7.2.4](#), only that part of the wall (including any openings) within the specified distance need be constructed in that manner.
(see [Figure 3.7.2.1](#), [Figure 3.7.2.2a](#) and [Figure 3.7.2.2b](#))
- (c) Where the distance measured is between attached or detached buildings of different heights, the distance must be taken from the *external wall* with the highest elevation measured at right angles to a point that intersects the nearest part of a vertical projection above the adjacent building, excluding any eave overhang (see [Figure 3.7.2.2b](#)).

State and Territory Variations

In South Australia after [3.7.2.3\(c\)](#) insert SA [3.7.2.3\(d\)](#) as follows:

- (d) The distance from any point on an *external wall* of a building to a *brush fence* is measured in any direction from the *external wall*.

Figure 3.7.2.1 Walls at right angles to the boundary

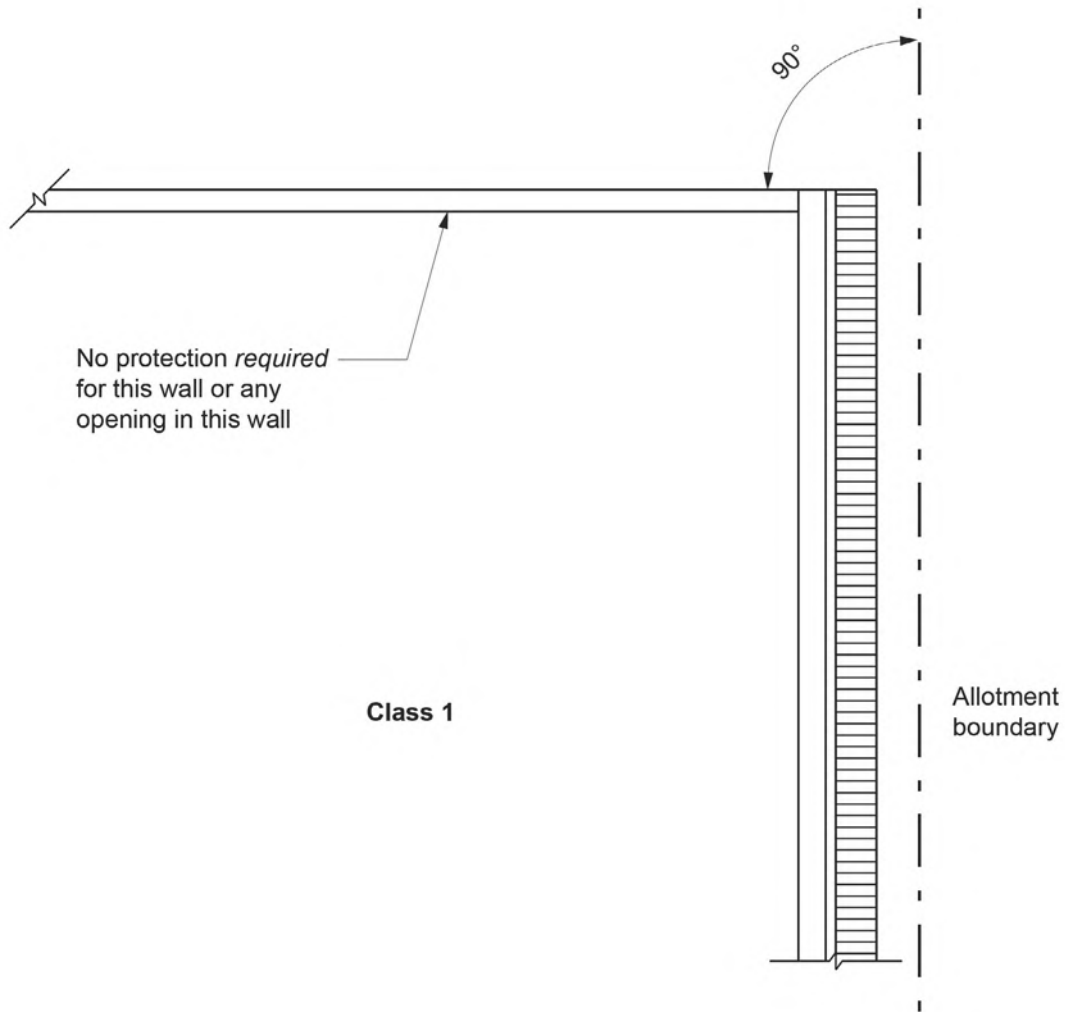

Notes to Figure 3.7.2.1:

1. No protection *required* for the wall at right angles or more to the boundary.
2. For protection of encroachments refer to 3.7.2.7.

Figure 3.7.2.2a Measurement of distances (Plan view)

Diagram a Full wall protection

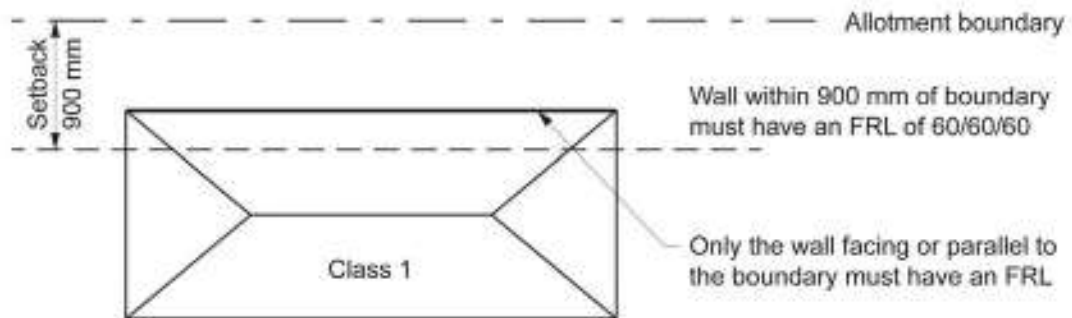
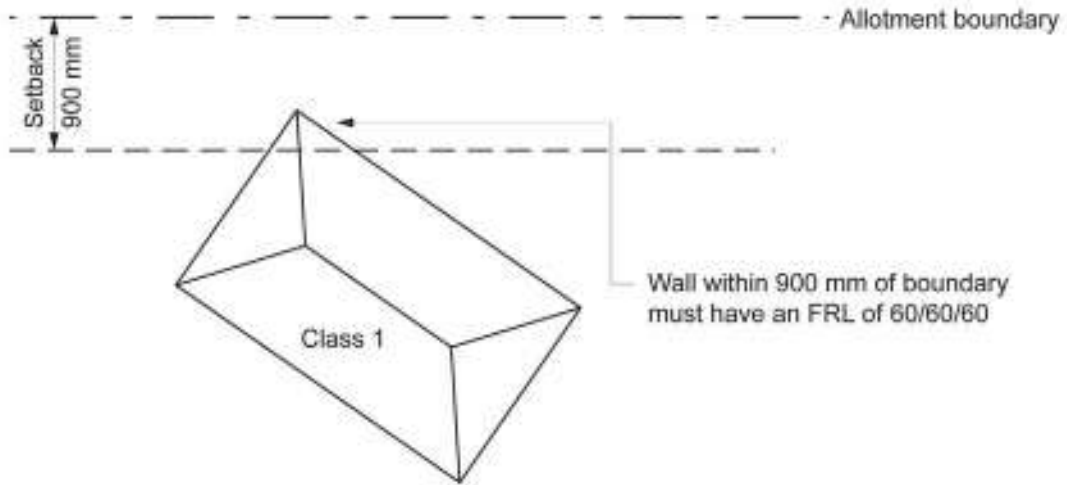

Figure 3.7.2.2a Measurement of distances (Plan view)

Diagram b Part walls protection



Note to Figure 3.7.2.2a: Setback distance is measured at right angles to the boundary.

Figure 3.7.2.2b Measurement of distance—Buildings of different heights

Diagram a Class 1 buildings on same allotment

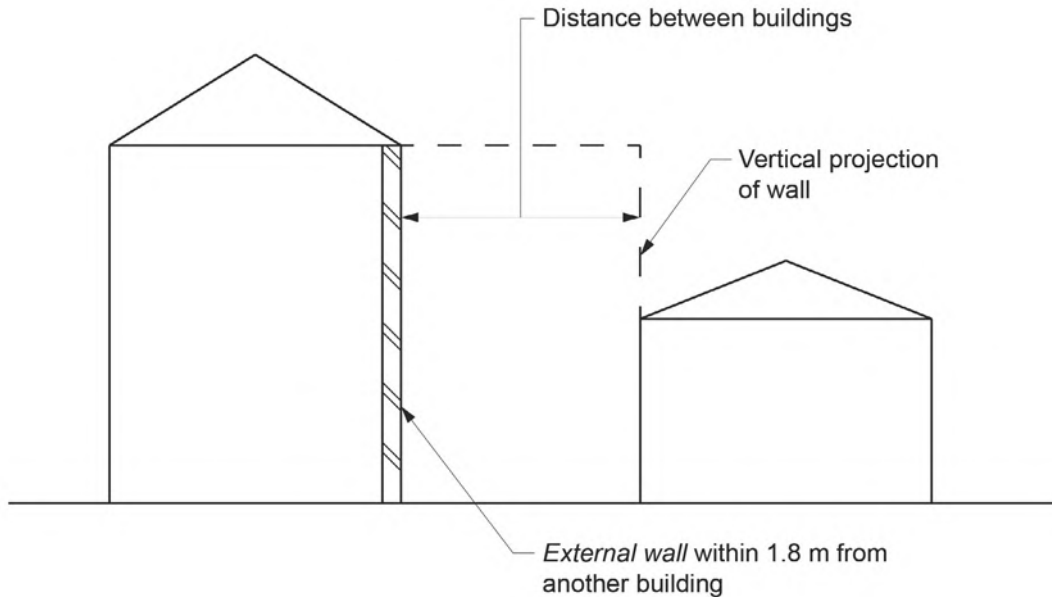
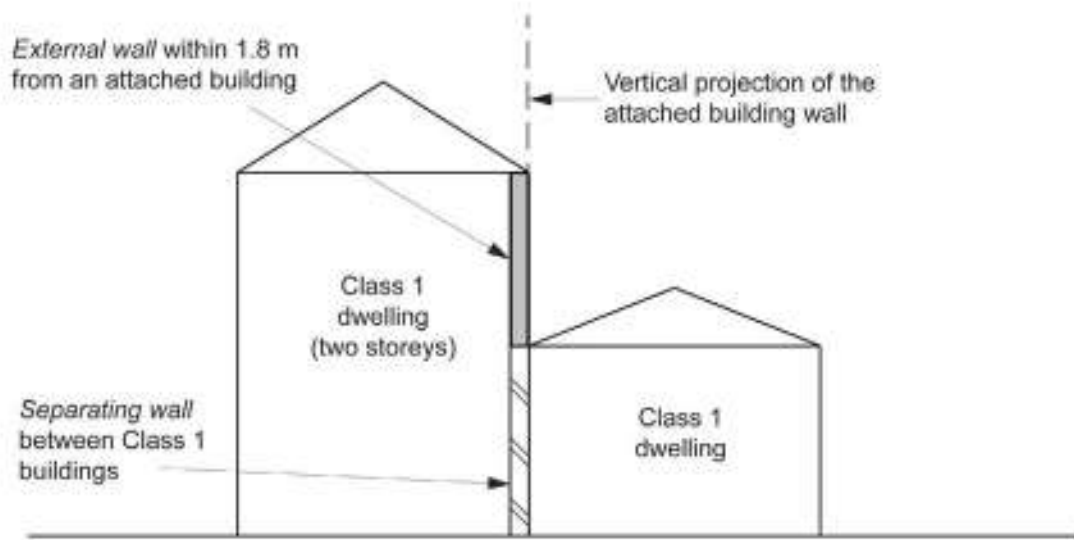

Diagram b Attached Class 1 buildings on same allotment



3.7.2.4 Construction of external walls

- (a) *External walls* (including gables) *required* to be *fire-resisting* (referred to in 3.7.2.2 or 3.7.2.5) must—
- (i) commence at the footings or ground slab, except where the *external wall* commences above a *separating wall* complying with 3.7.3.2 (see Figure 3.7.2.2b); and

Explanatory information:

A *Performance Solution* must be used where an *external wall required* to be *fire-resisting* does not commence in accordance with 3.7.2.4(a)(i).

- (ii) extend to—
 - (A) the underside of a *non-combustible* roof covering, except that a wall may terminate not more than 200 mm from the underside of a *non-combustible* roof covering, where the area between the *external wall* and underside of the roof covering is sealed with a *non-combustible* fascia, gutter or flashing; or
 - (B) the underside of a *non-combustible* eaves lining (See Figure 3.7.2.3); and
 - (iii) be constructed in accordance with (b).
- (b) A wall *required* by (a) must—
- (i) have an FRL of not less than 60/60/60 when tested from the outside; or
 - (ii) be of masonry-veneer construction in which the external masonry veneer is not less than 90 mm thick; or
 - (iii) be of masonry construction not less than 90 mm thick.

Explanatory information:

The intent of the typical construction details shown in Figure 3.7.2.3 is to ensure that combustible materials (external or internal) are not directly exposed to fire at the junction of the wall and *non-combustible* roof, eaves lining, guttering and the like. Other forms of construction may also be acceptable provided that they achieve this intent.

See Figure 3.7.2.1 and 3.8.6.4 for internal *separating wall* construction under one common roof.

Fire Safety

- (c) Openings in *external walls required* to be *fire-resisting* (referred to in 3.7.2.2 or 3.7.2.5) must be protected by—
- (i) non-openable fire *windows* or other construction with an FRL of not less than $-/60/-$; or
 - (ii) *self-closing* solid core doors not less than 35 mm thick.
- (d) The requirements (c) do not apply to a *window* in a non-*habitable room* that is located adjacent to and not less than 600 mm from the boundary of an adjoining allotment or 1200 mm from another building on the same allotment provided that—
- (i) in a bathroom, laundry or toilet, the opening has an area of not more than 1.2 m²; or
 - (ii) in a room other than one referred to in (i), the opening has an area of not more than 0.54 m² and—
 - (A) the *window* is steel-framed, there are no opening sashes and it is glazed in wired glass; or
 - (B) the opening is enclosed with translucent hollow glass blocks.
- (e) Subfloor vents, roof vents, weepholes, control joints, construction joints and penetrations for pipes, conduits and the like need not comply with (c).

Figure 3.7.2.3 Typical construction of external walls

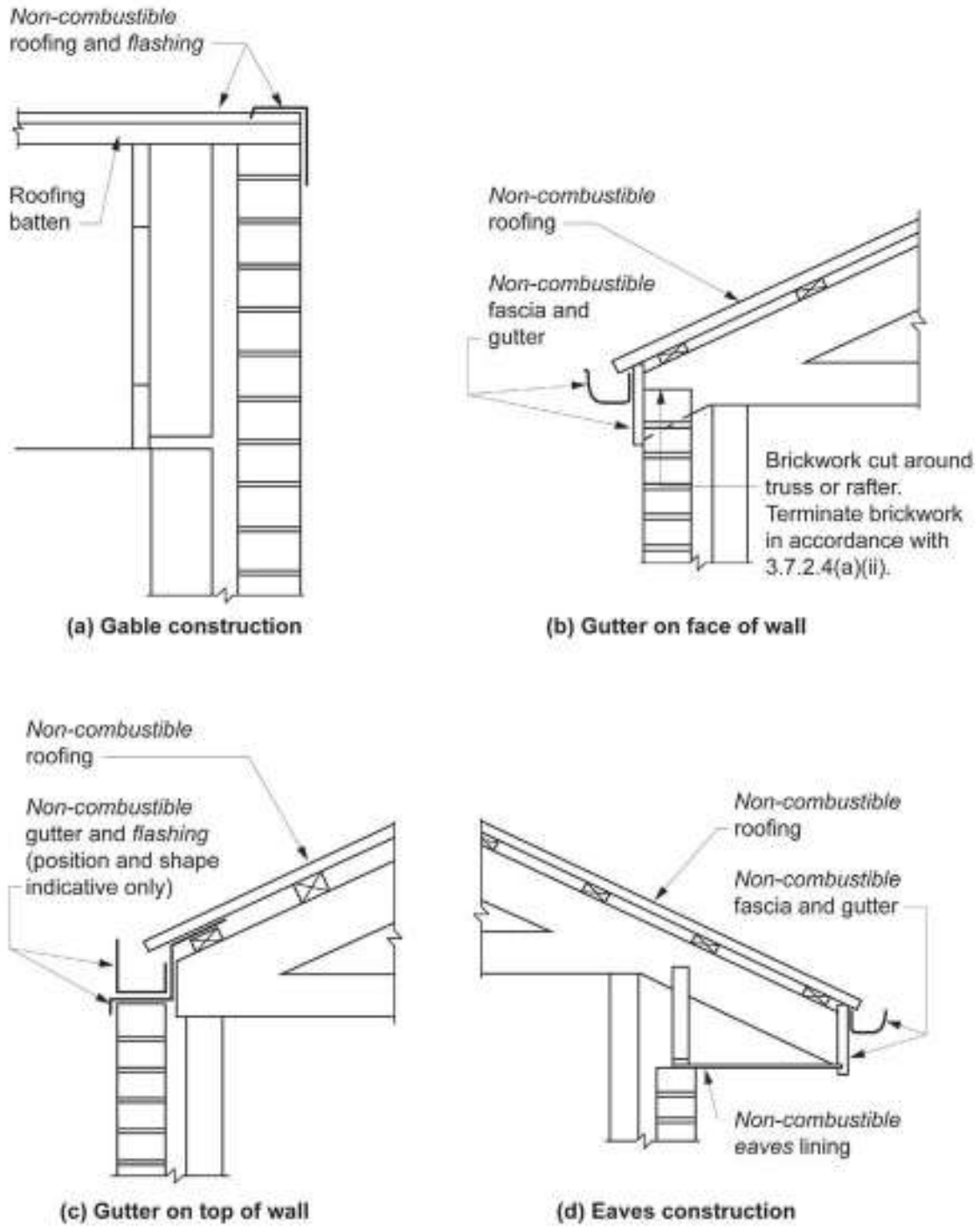

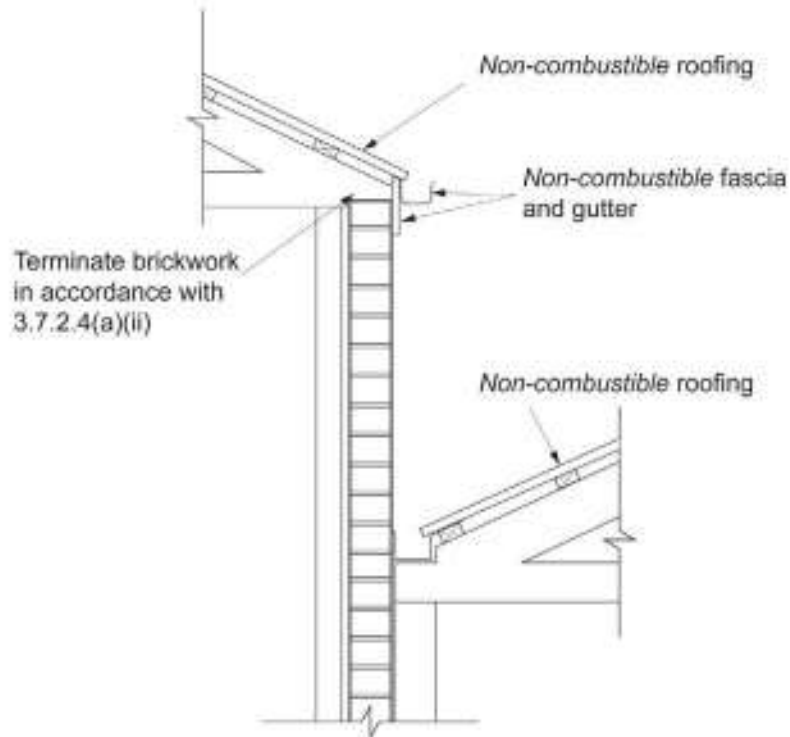

(e) Attached Class 1 buildings on the same allotment

Notes to Figure 3.7.2.3:

1. The *external wall* is deemed to extend to the underside of *non-combustible* roof covering, or *non-combustible* eaves lining, when constructed as shown.
2. Where sarking is installed it must be located so that ponding of water is avoided between the fascia and the first roofing batten.
3. The location of flashing and framing is indicative only.

3.7.2.5 Class 10a buildings

- (a) A Class 1 building must be protected by a method in—
 - (i) [Figure 3.7.2.4](#) where a Class 10a building is located between or adjacent to a Class 1 building and a boundary alignment that is not a boundary with a road alignment or other public space; or
 - (ii) [Figure 3.7.2.5](#) where a Class 10a building is located between or adjacent to a Class 1 building it is associated with and another building on the same allotment; or
 - (iii) [Figure 3.7.2.6](#) where two or more Class 10a buildings on the same allotment are located between and are associated with different Class 1 buildings.
- (b) A Class 10a building must not significantly increase the risk of spread of fire between Class 2 to 9 buildings.

Explanatory information:

[3.7.2.5\(a\)](#) ensures that when a Class 10 building is located between an allotment boundary and a Class 1 building or another building on the same allotment, either directly or indirectly, that the Class 1 building be protected by a wall with an FRL.

The intention is to prevent the spread of fire from an allotment boundary (fire source feature) to a Class 1 building via a Class 10a building. Where a Class 10a building is not sited directly and wholly between the allotment boundary and the Class 1 building (see [Figure 3.7.2.4 diagrams f. to i.](#)), the potential of fire spreading from the allotment boundary to the Class 1 still exists. Therefore fire separation would be *required*.

[3.7.2.5](#) does not apply to a boundary that adjoins a road or public space such as parklands, lakes, rivers and the like where the construction of buildings is unlikely.

State and Territory Variations

In South Australia after 3.7.2.5(b) insert SA 3.7.2.5(c) and (d) as follows:

- (c) A carport or verandah may have timber posts and timber roof support beams regardless of the distance from the boundary.
- (d) A Class 10b *brush fence* must not be constructed within 3 m of a Class 1 building unless any part of the building within 3 m of the *brush fence* complies with the *fire-resisting* requirements of 3.7.2.2, 3.7.2.3, 3.7.2.4 and 3.7.2.7.

Figure 3.7.2.4 Protection of Class 1 buildings—Class 10a between Class 1 and the allotment boundary

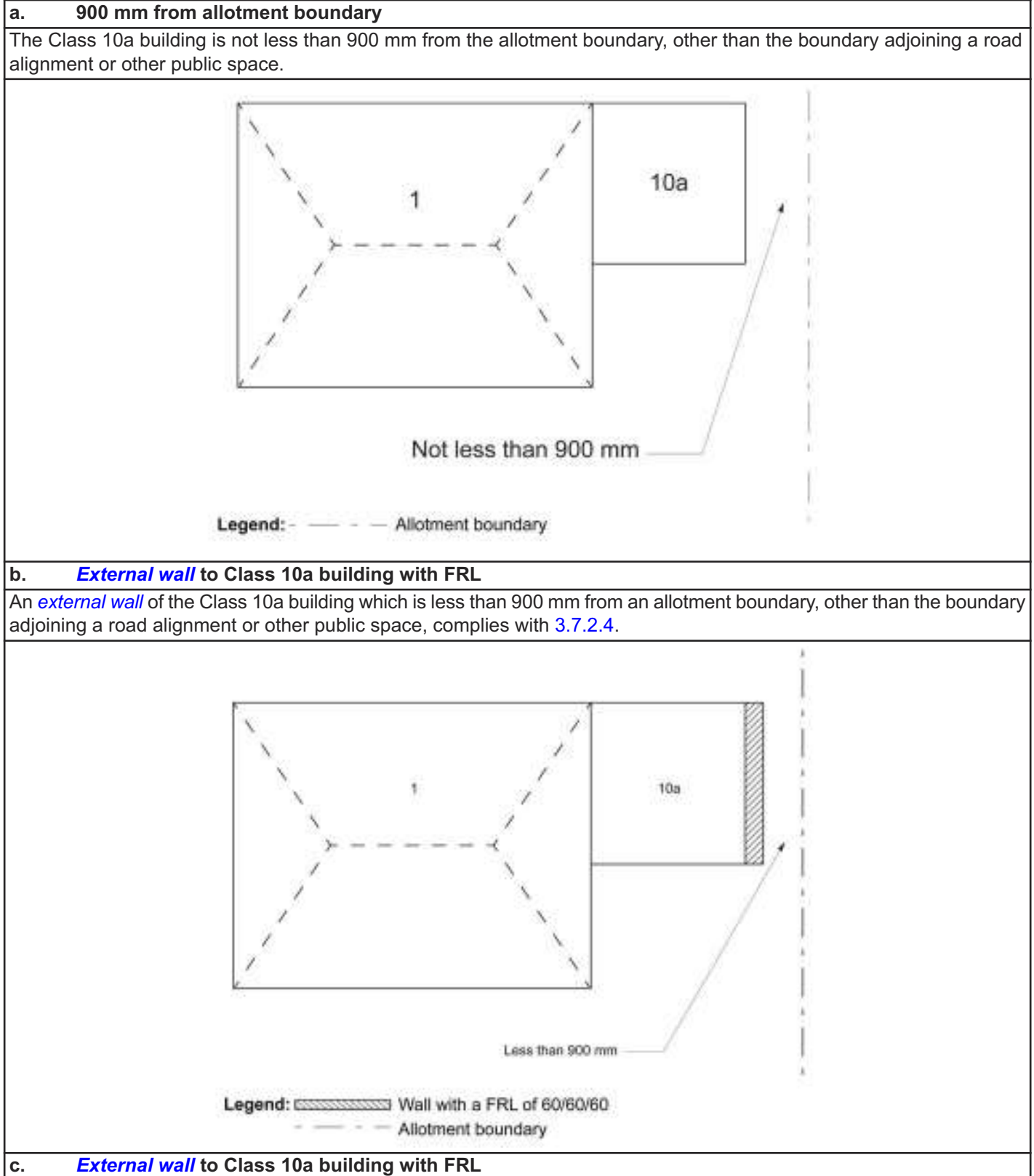

Fire Safety

An *external wall* of the Class 10a building, which is less than 900 mm from the Class 1 building, complies with 3.7.2.4.

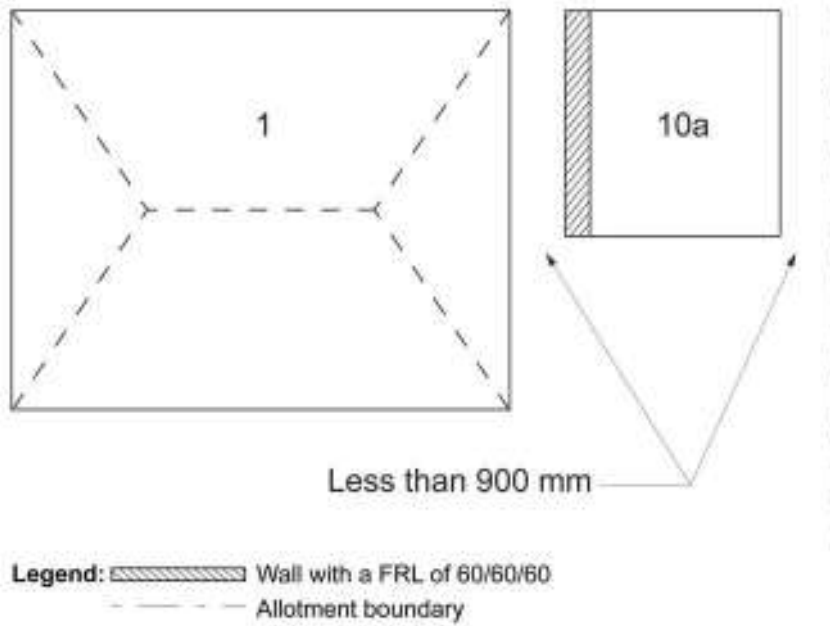

d. 900 mm separation between buildings

The Class 1 building is not less than 900 mm from the Class 10a building.

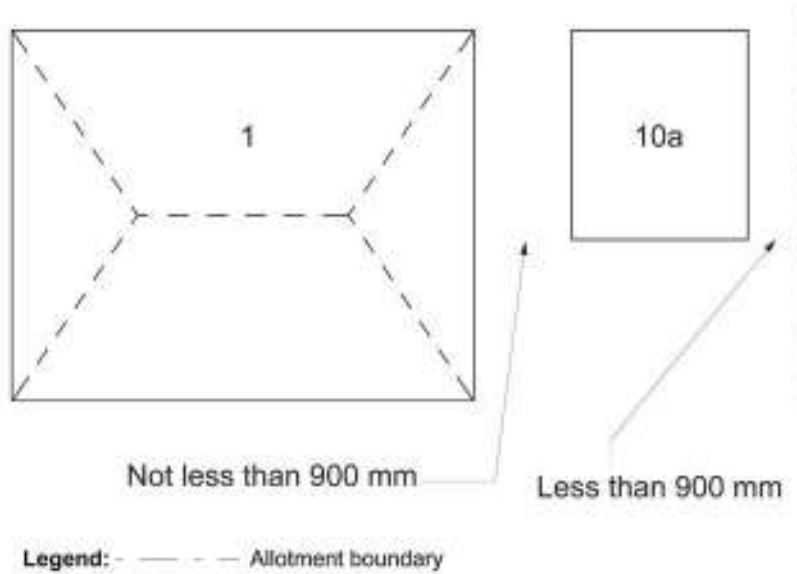

e. Class 1 building with FRL to *external wall*

An *external wall* of the Class 1 building, which is less than 900 mm from the Class 10a building, complies with 3.7.2.4.

Fire Safety

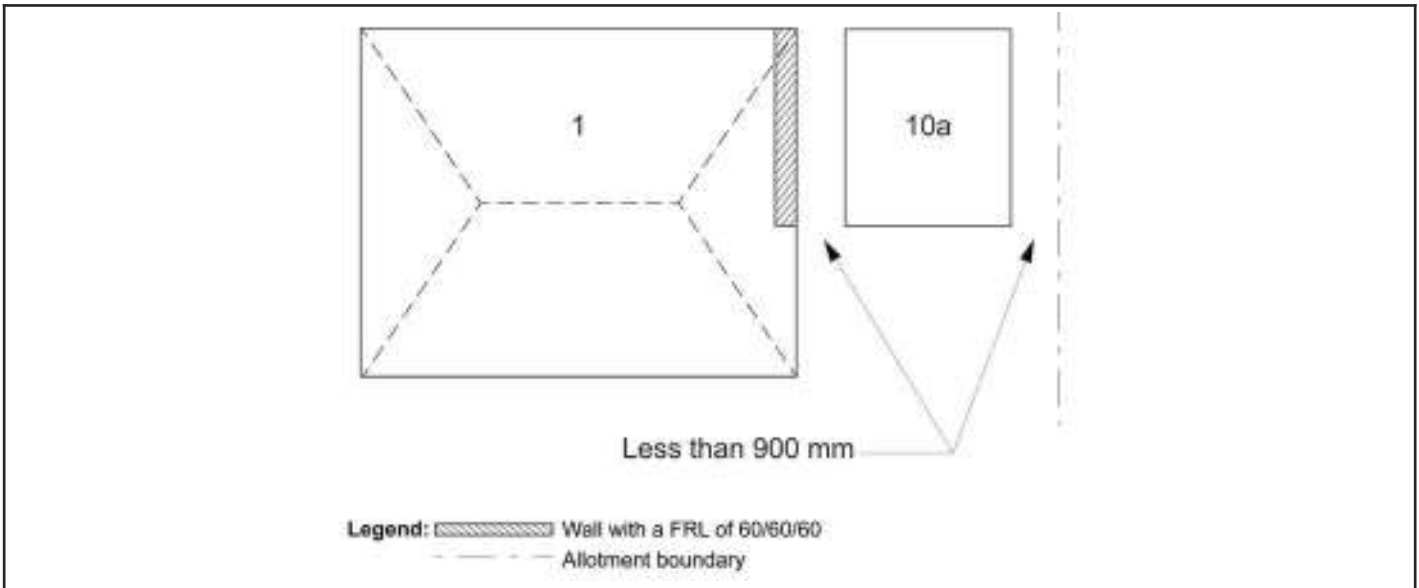

f. **External wall** of adjacent Class 10a building with FRL

An **external wall** of the Class 10a building which is less than 900 mm from an allotment boundary other than the boundary adjoining a road alignment or other public space, complies with 3.7.2.4.

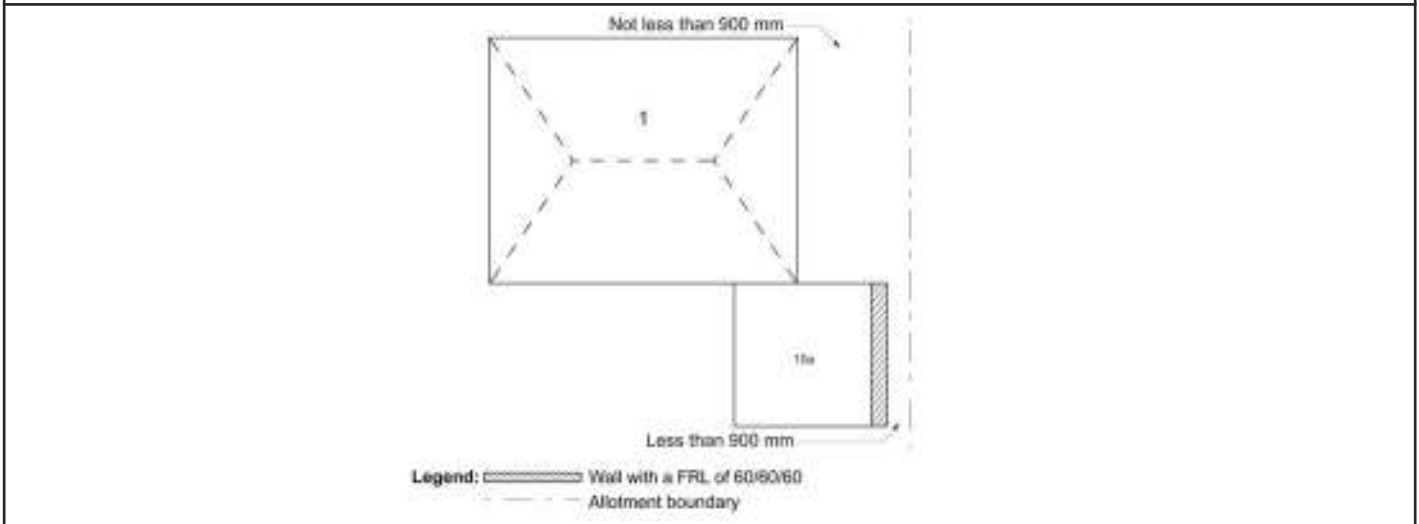

g. **External wall** of an adjacent Class 10a building with FRL

An **external wall** of the Class 10a building, which is less than 900 mm from the **external wall** of the Class 1 building, complies with 3.7.2.4.

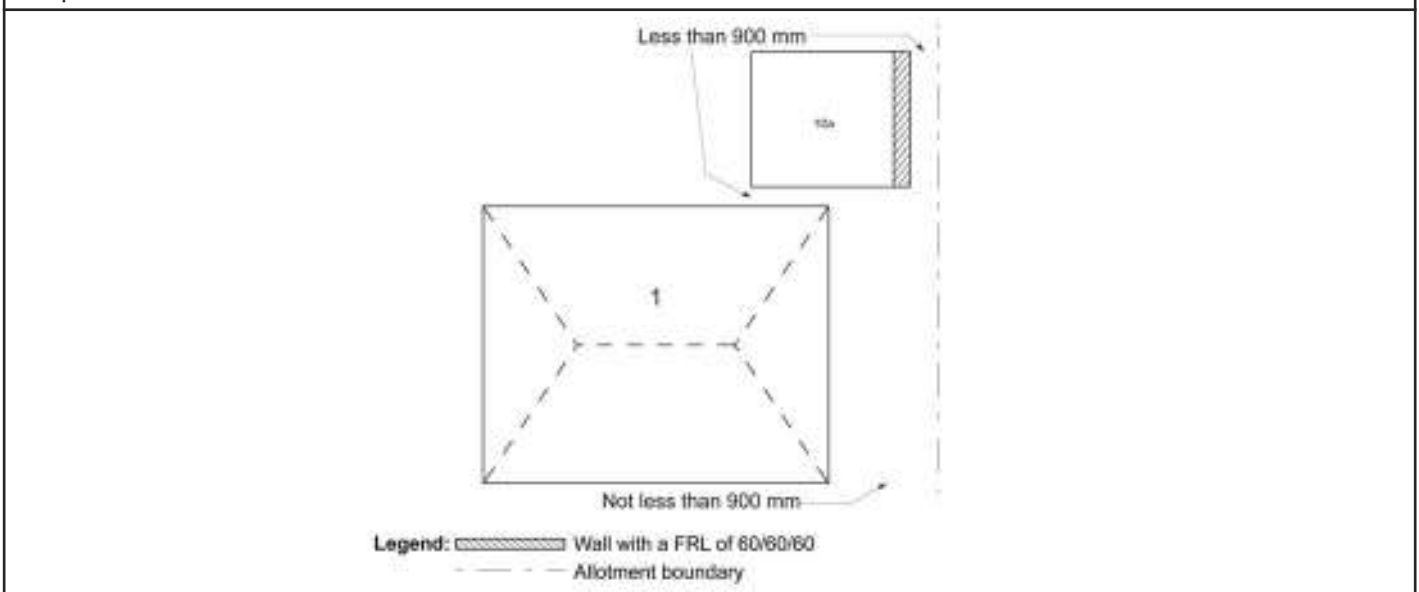

h. **Class 1 building with FRL to external wall**

Fire Safety

An *external wall* of the Class 1 building, which is less than 900 mm from a Class 10a building that is situated less than 900 mm from an allotment boundary, complies with 3.7.2.4.

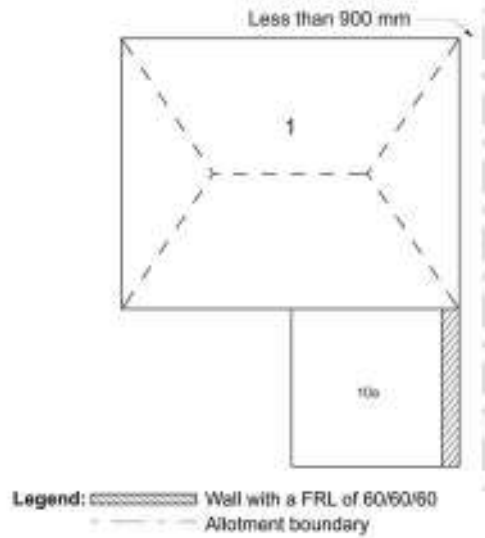

i. **External wall to Class 10a building with FRL**

The *external wall* of the Class 1 and Class 10a building which are less than 900 mm from an allotment boundary, other than the boundary adjoining a road alignment or other public space, complies with 3.7.2.4.

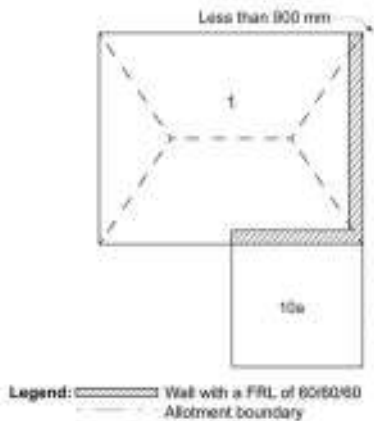
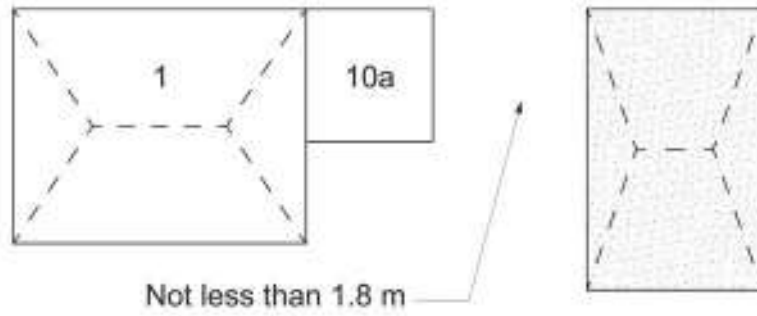

Figure 3.7.2.5 Protection of Class 1 buildings—Class 10a between Class 1 and other buildings on allotment

a. **1.8 m from other building on allotment**

The Class 10a building is not less than 1.8 m from the other building.

Fire Safety



Legend: Other class of building on allotment

b. **External wall** to Class 10a building with FRL

An **external wall** of the Class 10a building, which is less than 1.8 m from the other building, complies with 3.7.2.4.

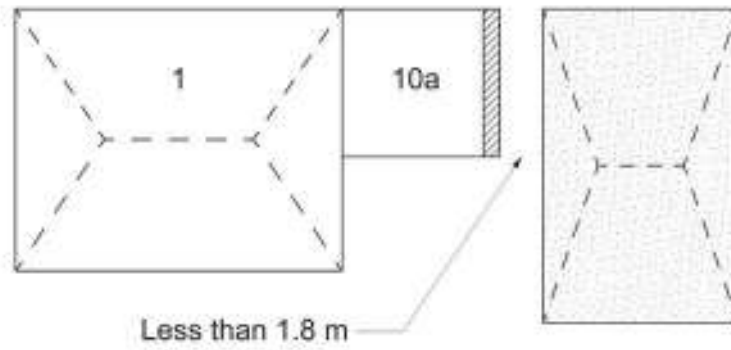

Legend: Wall with a FRL of 60/60/60
 Other class of building on allotment

c. **External wall** to Class 10a building with FRL

An **external wall** of the Class 10a building, which is less than 1.8 m from the Class 1 building, complies with 3.7.2.4.

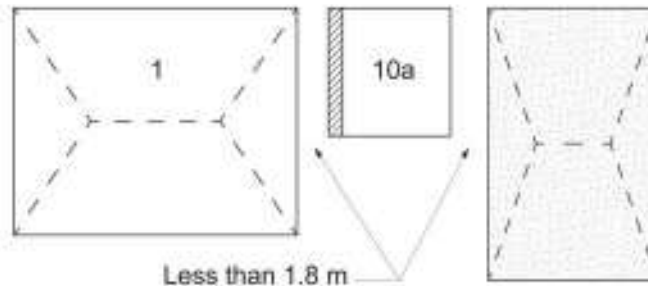



Legend: Wall with a FRL of 60/60/60
 Other class of building on allotment

d. **1.8 m separation** between Class 1 and 10a

Fire Safety

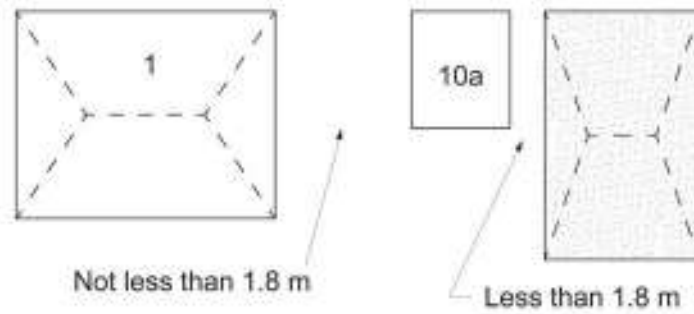
The Class 1 building is not less than 1.8 m from the Class 10a building.





Legend:  Other class of building on allotment

e. Class 1 building with FRL to *external wall*

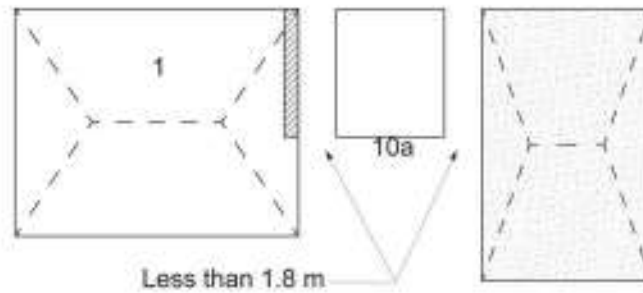
An *external wall* of the Class 1 building, which is less than 1.8 m from the Class 10a building, complies with 3.7.2.4.





Legend:  Wall with a FRL of 60/60/60
 Other class of building on allotment

f. *External wall* of adjacent Class 10a building with FRL

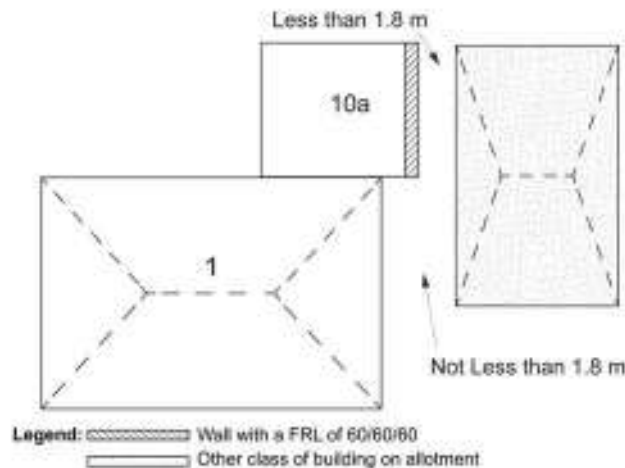
An *external wall* of the Class 10a building, which is less than 1.8 m from the *external wall* of the other building, complies with 3.7.2.4.



Legend:  Wall with a FRL of 60/60/60
 Other class of building on allotment

g. *External wall* of adjacent Class 10a building with FRL

An *external wall* of the Class 10a building, which is less than 1.8 m from the *external wall* of the Class 1 building, complies

with 3.7.2.4.

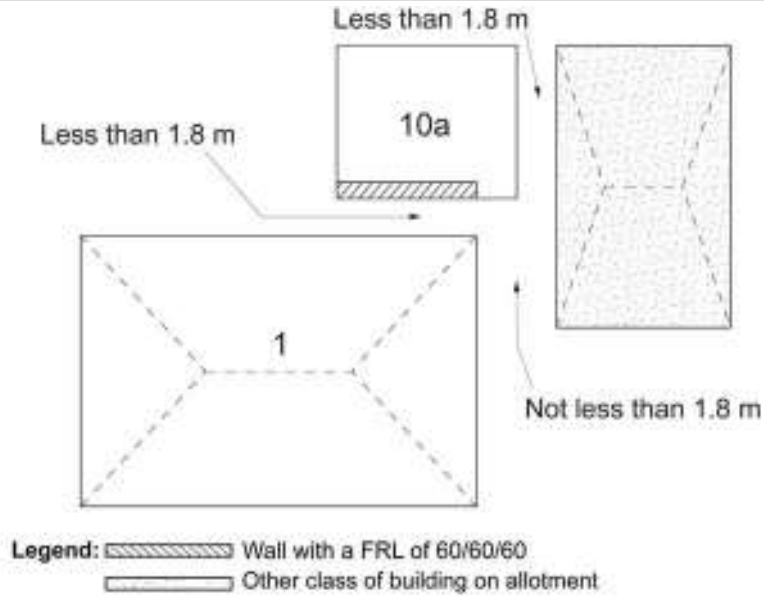

h. Class 1 and 10 building with FRL to external wall

An external wall of the Class 1 and 10a building, which is less than 1.8 m from the external wall of the other building, complies with 3.7.2.4.

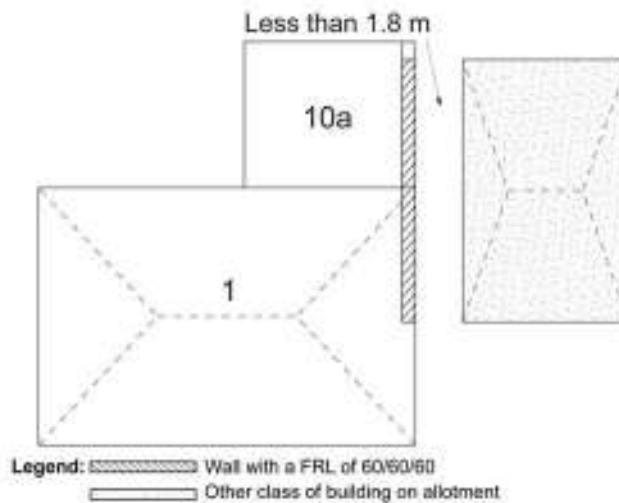
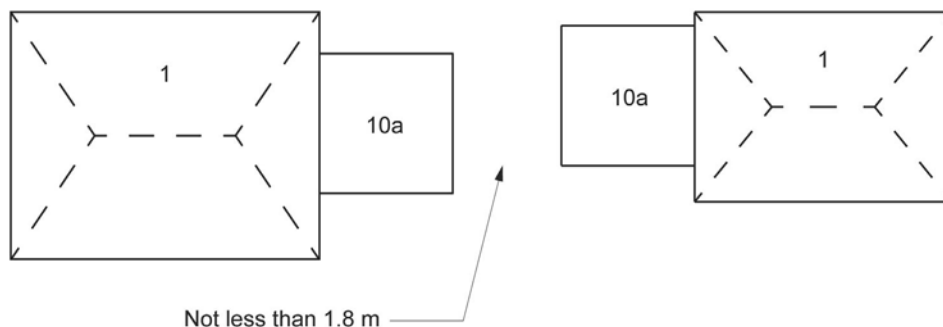

Figure 3.7.2.6 Protection of Class 1 buildings—separation of Class 10a buildings on an allotment

a. 1.8 m between Class 10a buildings

Each Class 10a building must be separated from each other by a distance of not less than 1.8 m.



Fire Safety

b. External wall to Class 10a building with FRL

Each Class 10a building must be separated from each other by external walls complying with 3.7.2.4.

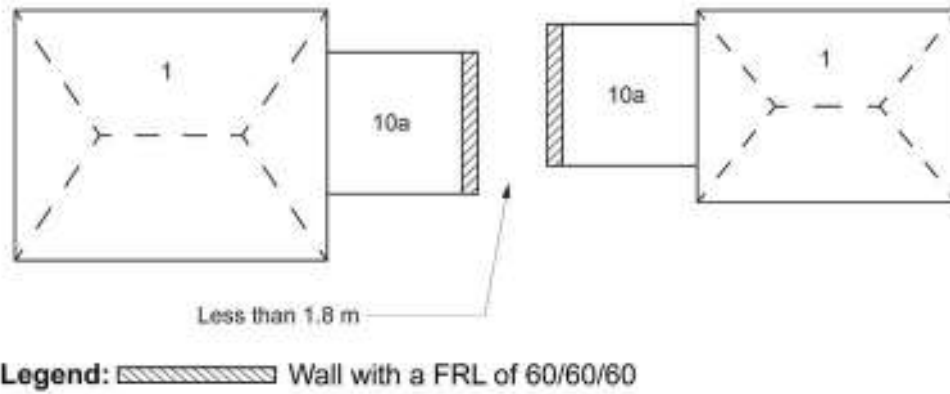

c. 900 mm separation between Class 10a and Class 1 buildings

Each Class 10a building must be separated from each Class 1 building by a distance of not less than 900 mm.

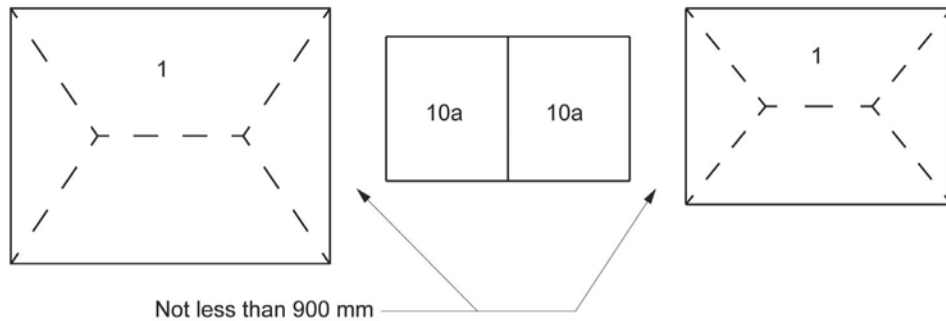

d. External wall to Class 10a buildings with FRL

Each Class 10a building must be separated from each Class 1 building by external walls complying with 3.7.2.4.

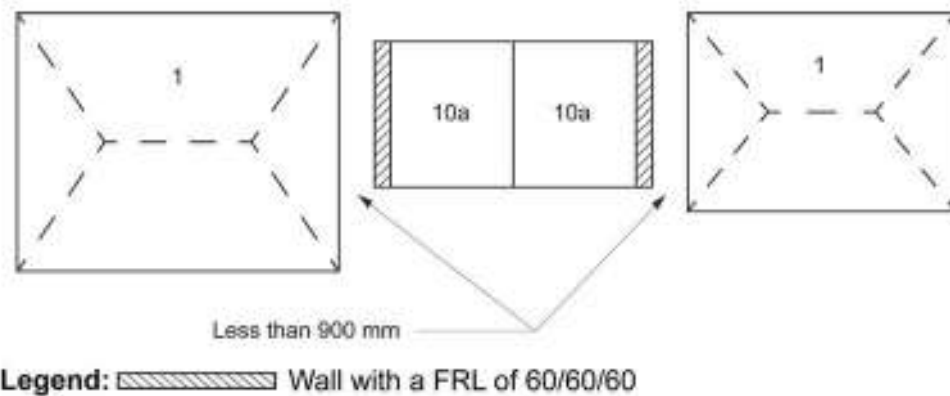

e. Class 10a buildings with FRL to separating wall

Each Class 10a building must be separated by a wall complying with 3.7.3.2.

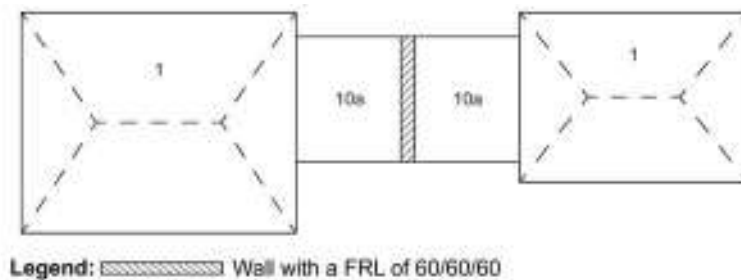

Fire Safety

f. **External wall to adjacent Class 10a buildings with FRL**

Each Class 10a building must be separated from each other by **external walls** complying with 3.7.2.4.

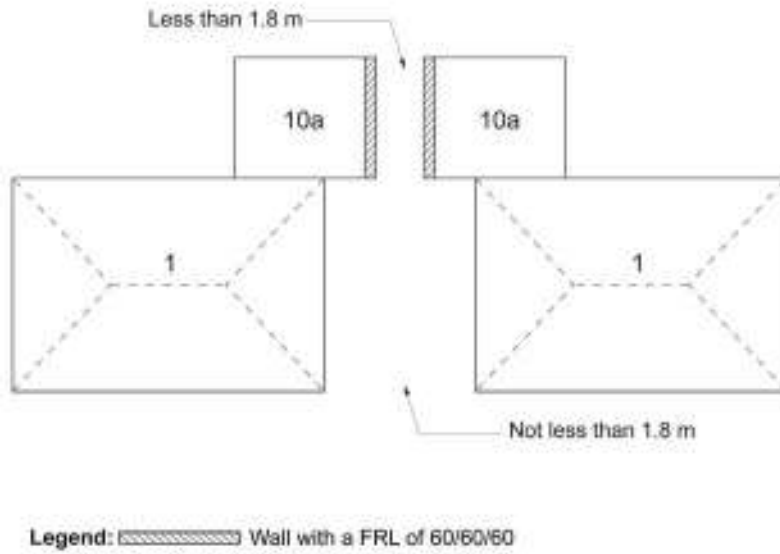

g. **External wall to adjacent Class 10a buildings with FRL**

Each Class 10a building must be separated from each Class 1 building by **external walls** complying with 3.7.2.4.

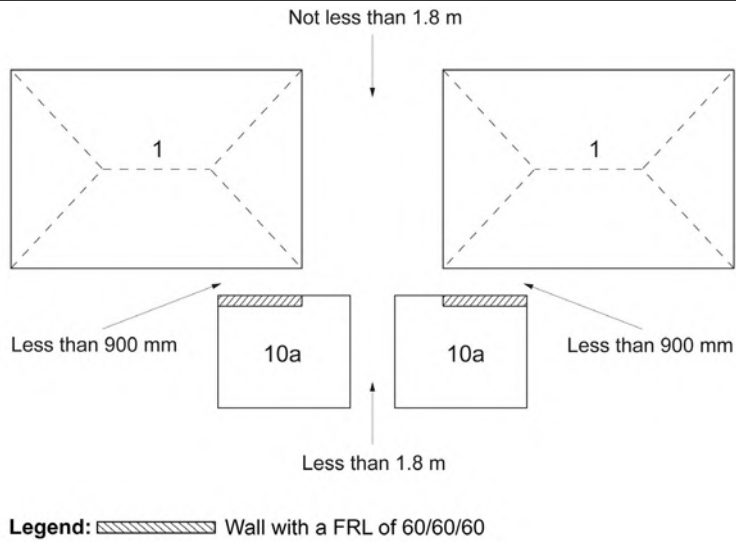

h. **Class 10a buildings with FRL to separating wall**

Each Class 10a building must be separated by a wall complying with 3.7.3.2.

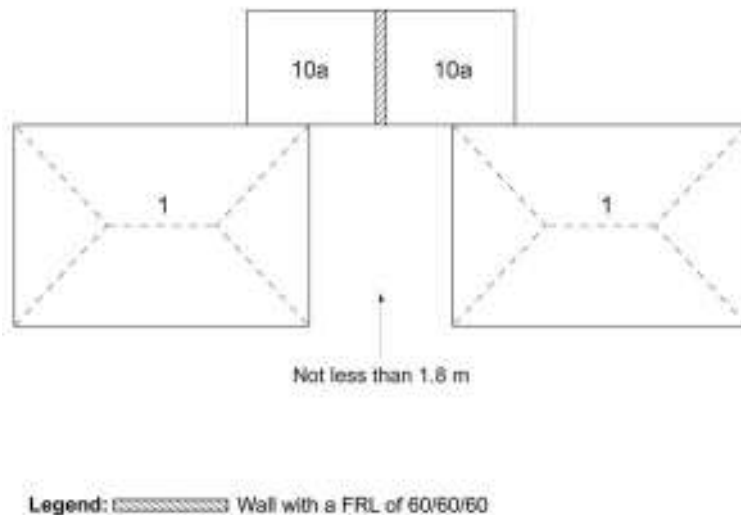

3.7.2.6 Open carports

- (a) A Class 10a carport is exempt from complying with 3.7.2.5(a) if—
 - (i) it has two or more sides open and not less than one third of its perimeter open; and
 - (ii) for the purposes of (i), a side is considered to be open if the roof covering adjacent to that side is not less than 500 mm from another building or allotment boundary; and
 - (iii) it has a polycarbonate or *non-combustible* roof covering; and
 - (iv) any ceiling lining and wall cladding, including gables, is *non-combustible* (see Figure 3.7.2.7); and
 - (v) it does not provide direct vertical support to any part of the Class 1 building; and
 - (vi) in the case where it has a common roof structure with the Class 1 building and the carport does not have a ceiling (See Figure 3.7.2.8), the opening between the top of the wall of the Class 1 building and the underside of the roof covering is infilled with—
 - (A) a *non-combustible* material; or
 - (B) construction clad with *non-combustible* material on the carport side.

Explanatory information:

A side of a carport enclosed by a vehicle access door is not considered to be an open side.

Figure 3.7.2.7 Identifying an open carport

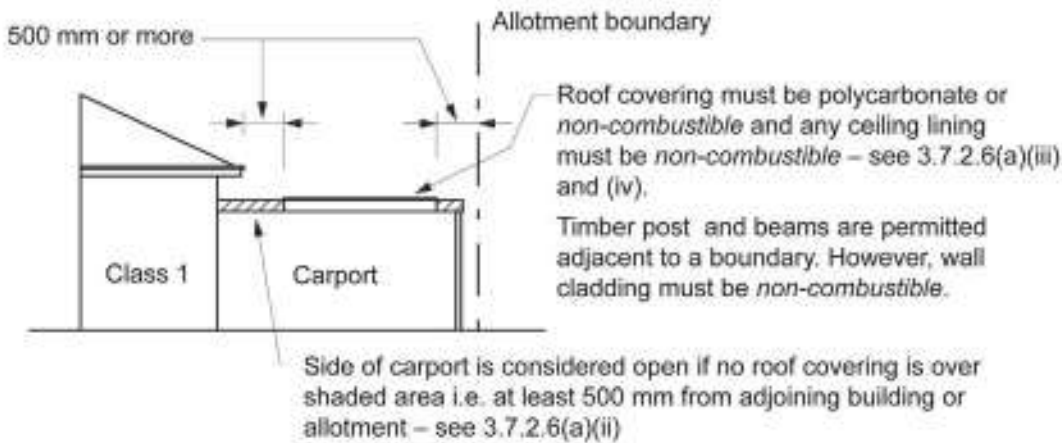

(a) Example A

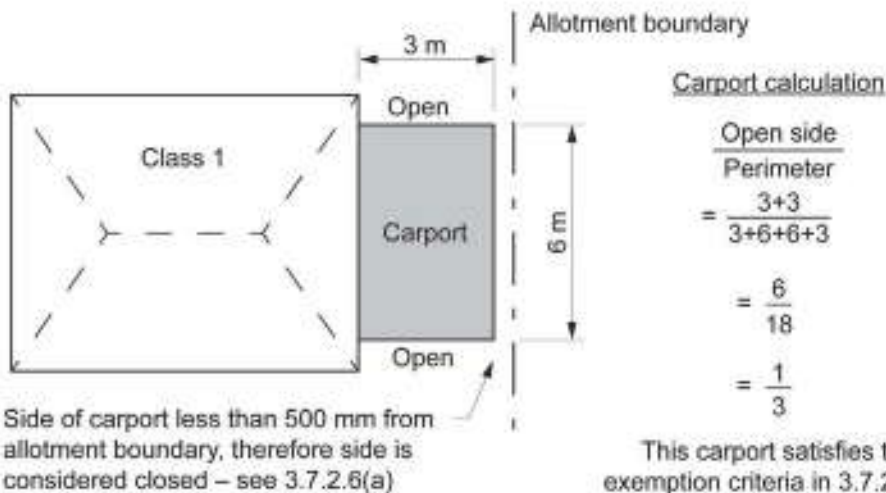

(b) Example B

State and Territory Variations

In South Australia delete 3.7.2.6(a) and insert SA 3.7.2.6(a) as follows:

- (a) A carport or verandah is exempt from 3.7.2.5(a) if—
- (i) it has—
 - (A) two or more sides open and not less than one third of its perimeter open and, for the purpose of this clause, a side is considered to be open if the roof covering adjacent to that side is not less than 500 mm from another building or allotment boundary; or
 - (B) any part of the *external wall* of the Class 1 building located less than 2 m from the allotment boundary or less than 4 m from another Class 1 building on the same allotment is *fire-resisting* to the underside of a *non-combustible* roof covering or to the underside of a *non-combustible* ceiling lining (see Figure SA 3.7.2.7a, Figure SA 3.7.2.7b and Figure SA 3.7.2.7c); and
 - (ii) it has polycarbonate or *non-combustible* roof covering and any ceiling lining and wall cladding, including gables, is also *non-combustible* (see Figure 3.7.2.7); and
 - (iii) it does not provide direct vertical support to any part of the Class 1 building; and
 - (iv) in the case where it has a common roof structure with the Class 1 building and the carport or verandah does not have a ceiling (see Figure 3.7.2.8), the opening between the top of the wall of the Class 1 building and the underside of the roof covering is infilled with—
 - (A) a *non-combustible* material; or
 - (B) construction clad with *non-combustible* material on the carport or verandah side; and
 - (v) in the case where two carports or verandahs have a common roof structure with two different Class 1 buildings and the carports or verandahs have a ceiling, the roof space or ceiling space between the top of the ceiling and the underside of the roof covering is infilled as follows—
 - (A) vertically between the two Class 1 buildings and between the two appurtenant carports or verandahs in accordance with SA 3.7.2.6(a)(iv) (see Figure SA 3.7.2.6d); or
 - (B) vertically between the two Class 1 buildings and between the two appurtenant carports or verandahs in accordance with SA 3.7.2.6(a)(iv), except that the construction must be clad with *non-combustible* materials on both sides and must not be crossed by timber or other *combustible* building elements except for roof battens with dimensions of 75 × 50 mm or less, roof sarking-type material or a timber gutter board not less than 20 mm thick.

Figure SA 3.7.2.7a

Fire-resisting requirements for carports or verandahs without a ceiling

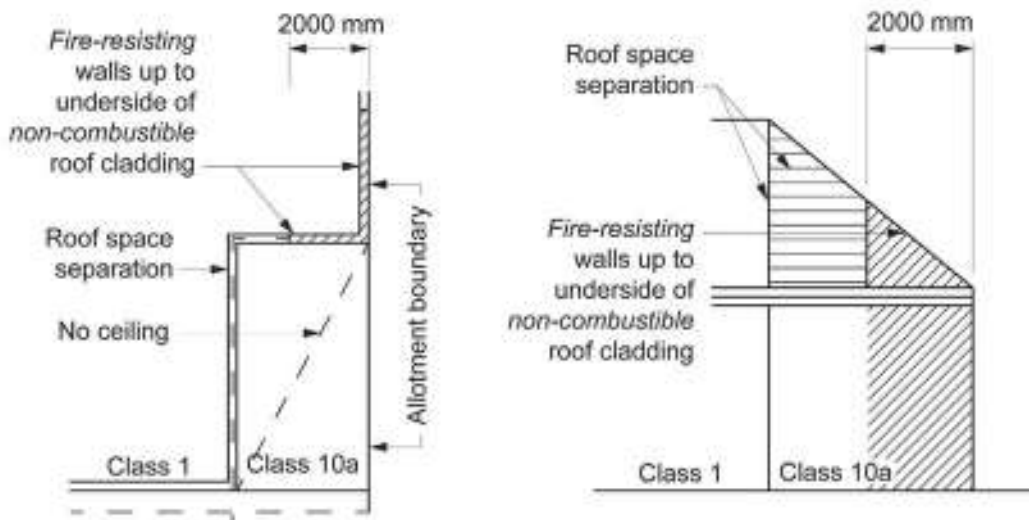

Figure SA 3.7.2.7b

Fire-resisting requirements for carports or verandahs with a non-combustible ceiling

Fire Safety

Figure SA 3.7.2.7b

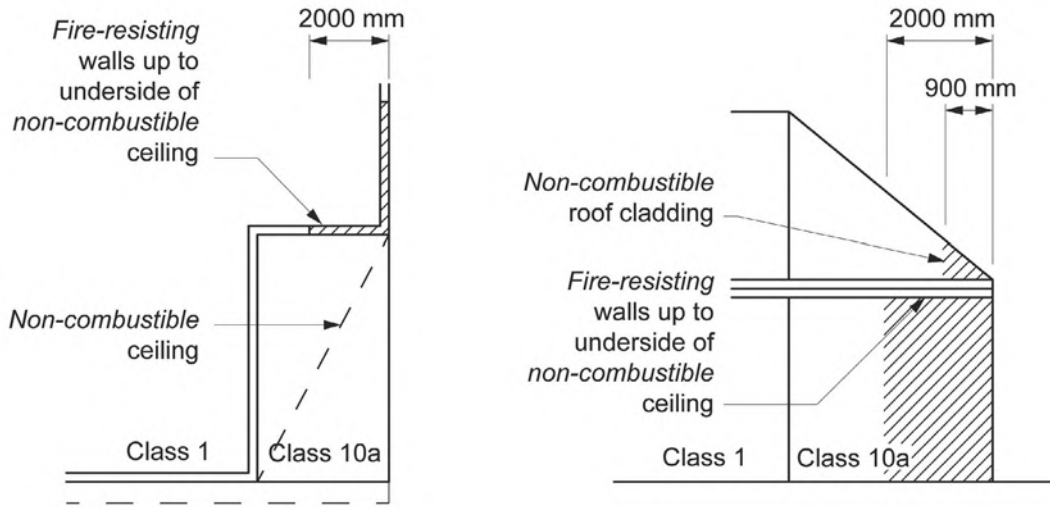

Figure SA 3.7.2.7c

Fire-resisting requirements for external walls in carports and verandahs that share a common roof space

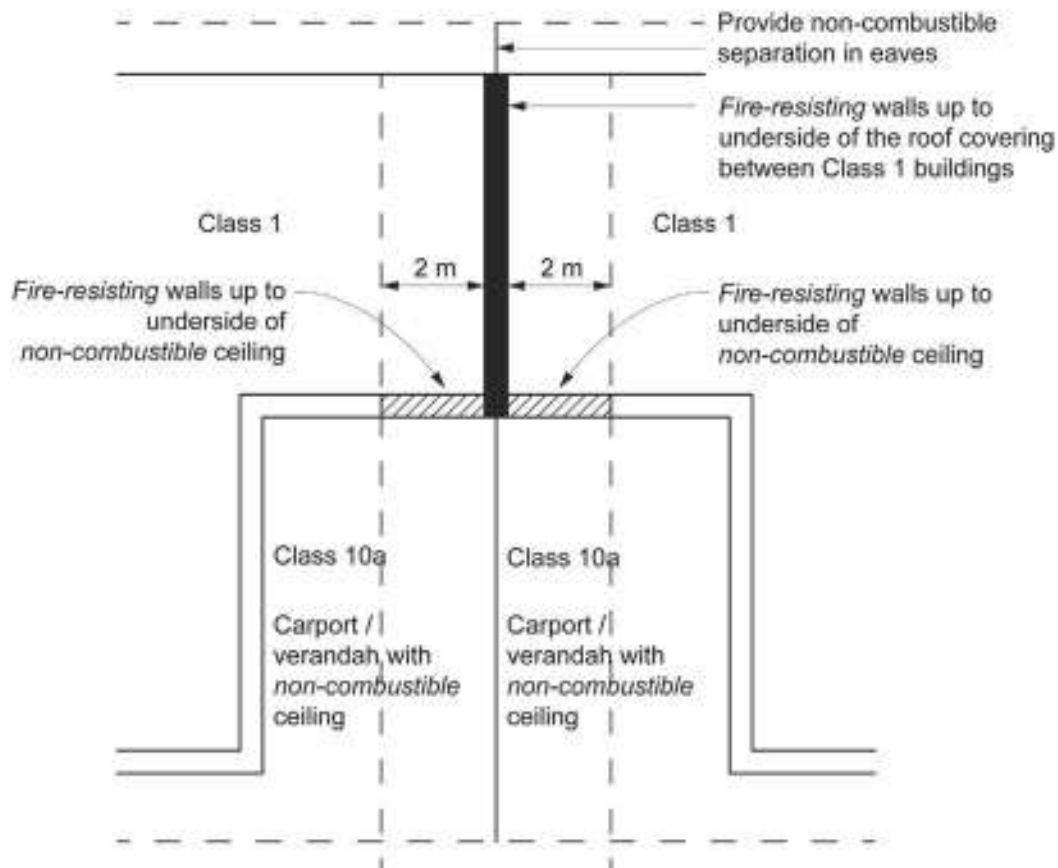
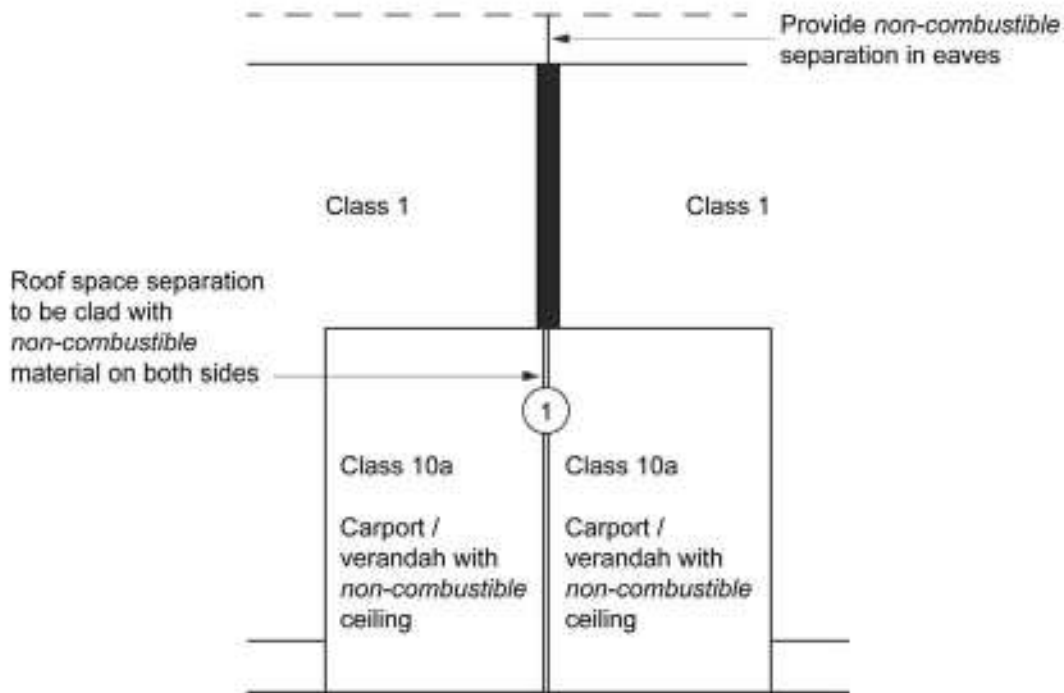

Figure SA 3.7.2.7d

Fire-resisting requirements for roof space openings in carports and verandahs with a ceiling that share a common roof space

Figure SA 3.7.2.7d



NOTE: If under main roof, provide roof separation at 1 from ceiling to underside of *non-combustible* roof cladding

Figure 3.7.2.8 Requirements for non-combustible infill panels to carport

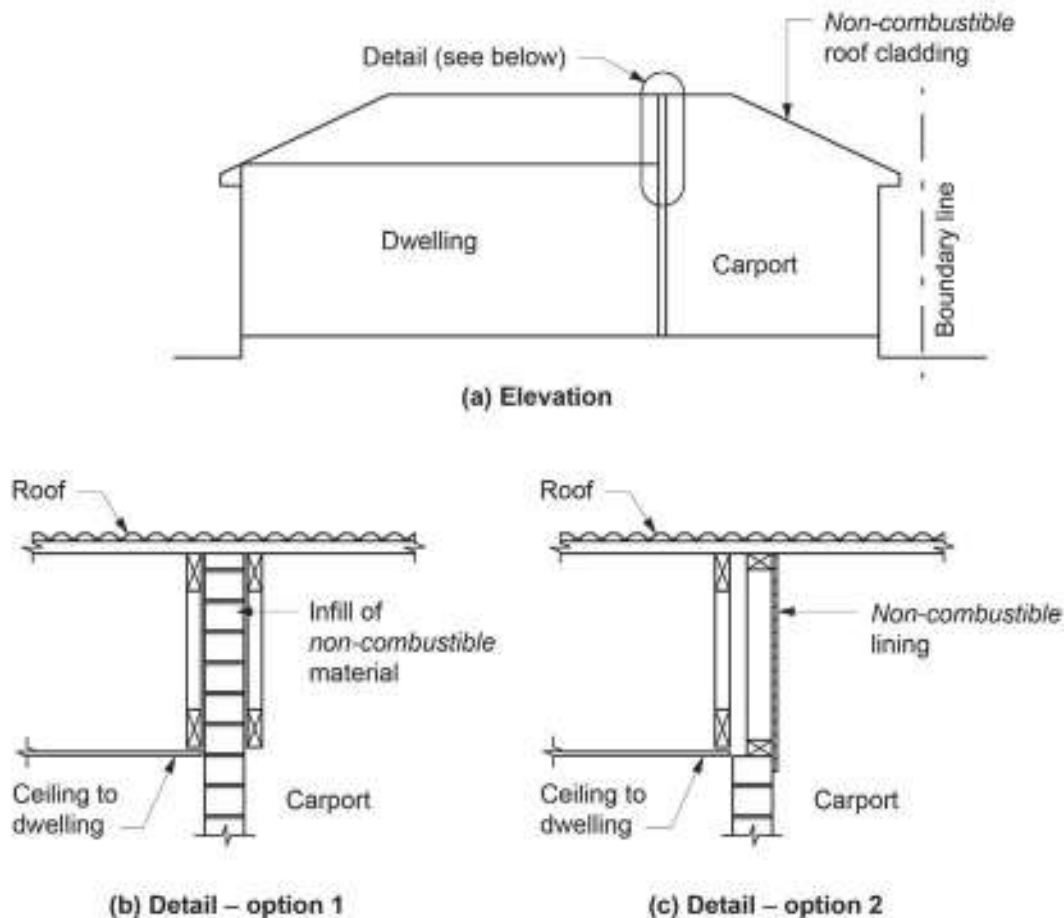

3.7.2.7 Allowable encroachments

- (a) An encroachment is any construction between—
- the *external wall* of the building and the allotment boundary other than a boundary adjoining a road or other public space; or
 - the *external walls* of two buildings on the same allotment; or
 - the *external wall* of the building and the vertical projection of an adjoining building on the same allotment.
- (b) For the purposes of (a), an encroachment relates to any *external wall* of—
- a Class 10a building *required* to comply with 3.7.2.5; or
 - a Class 1 building.
- (c) Encroachments allowed within 900 mm of an allotment boundary or within 1.8 m of another building on the same allotment are—
- non-combustible* fascias, gutters and downpipes; and
 - light fittings, electricity or gas meters, aerials or antennas; and
 - pergolas, sun blinds or water tanks (see Figure 3.7.2.9); and
 - unroofed terraces, landings, steps and ramps, not more than 1 m in height.
- (d) Encroachments allowed up to but not closer than 450 mm from an allotment boundary or up to but not closer than 900 mm from another building on the same allotment or associated encroachments of another building on the same allotment are—
- combustible* fascias, gutters and downpipes (see Figure 3.7.2.9); and

Fire Safety

- (ii) eaves with *non-combustible* roof cladding and *non-combustible* lining; and
 - (iii) flues, chimneys, pipes, domestic fuel tanks, cooling or heating appliances or other services.
- (e) Encroachments allowed between an *external wall* of a building and the vertical projection of an adjoining building on the same allotment are *non-combustible* fascias, gutters and downpipes (see [Figure 3.7.2.3\(e\)](#)).

Explanatory information:

A deck is not considered an unroofed terrace and is therefore not permitted as an allowable encroachment under [3.7.2.7](#) whether *combustible* or not.

The term pergola is a reference to an unroofed structure.

Figure 3.7.2.9 Allowable encroachments for non-combustible construction

Diagram a Combustible fascia up to but not closer than 450 mm to an allotment boundary

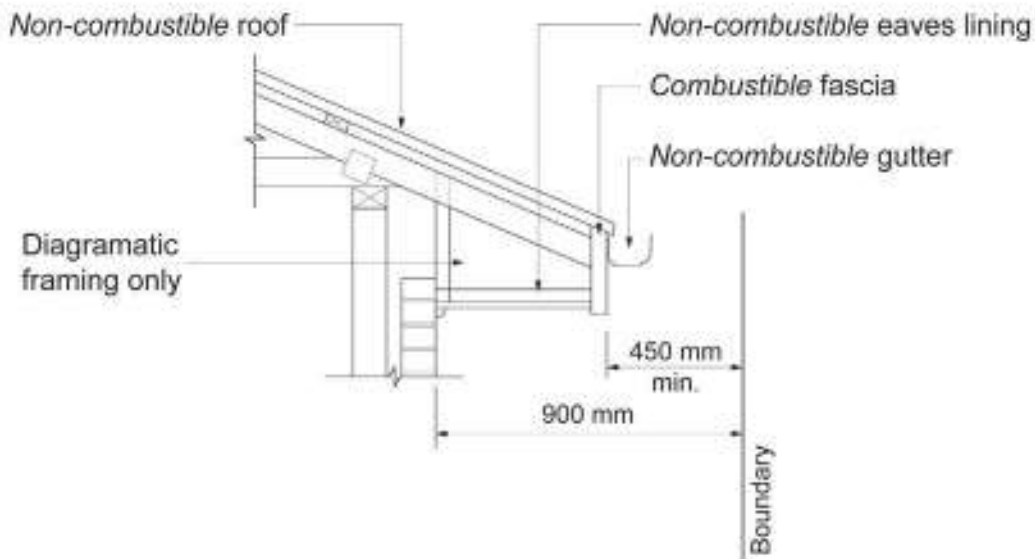

Fire Safety

Diagram b Non-combustible fascia and gutter within 900 mm of an allotment boundary

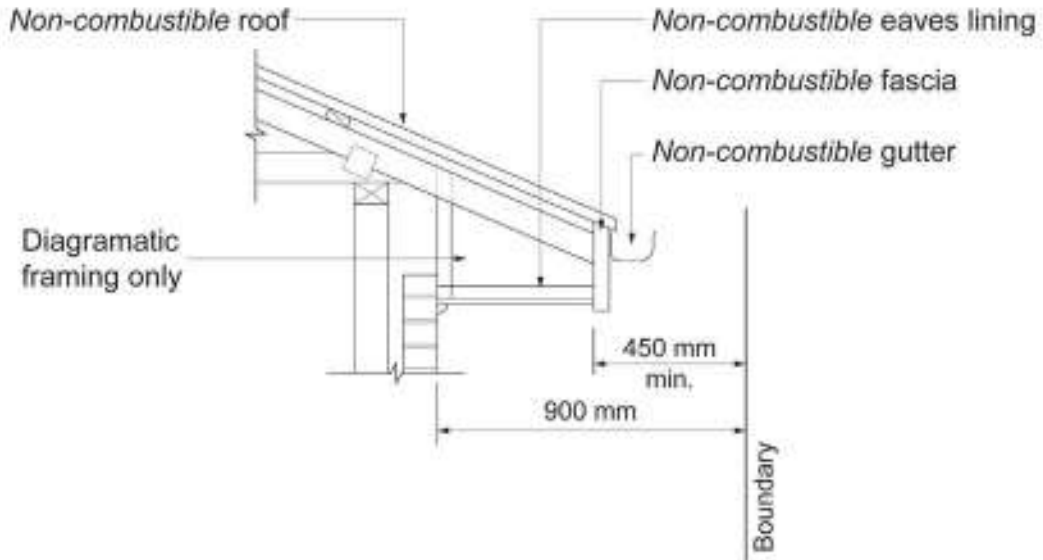
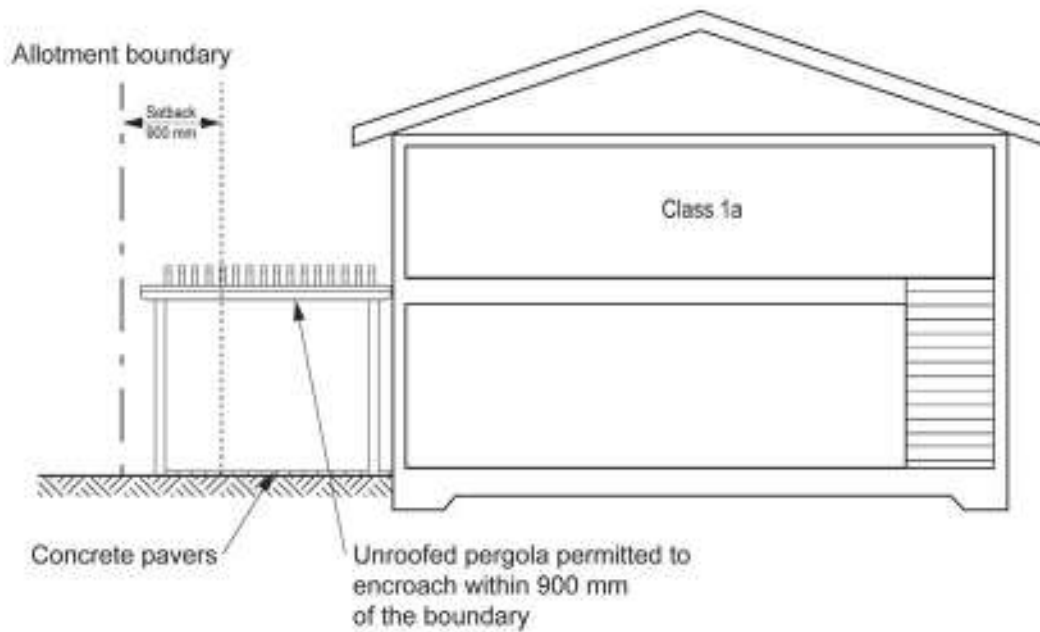

Diagram c Unroofed pergola within 900 mm of an allotment boundary



State and Territory Variations

In South Australia delete 3.7.2.7 and insert SA 3.7.2.7 and Figure SA 3.7.2.9a as follows:

- (a) An encroachment is any construction between—
- (i) the *external wall* of the building and the allotment boundary other than a boundary adjoining a road or other public space; or
 - (ii) the *external walls* of two buildings on the same allotment; or
 - (iii) the *external wall* of the building and a *brush fence*.
- (b) For the purposes of (a), an encroachment related to any *external wall* of—
- (i) a Class 10a building *required* to comply with 3.7.2.5; or
 - (ii) a Class 1 building.
- (c) The encroachments allowed within 900 mm of an allotment boundary or within 1.8 m of another building on the same allotment or within 3 m of a *brush fence* are—
- (i) *non-combustible* fascias, gutters and downpipes; and
 - (ii) light fittings, electricity or gas meters, aerials or antennas; and
 - (iii) pergolas, sun blinds or water tanks; and
 - (iv) unroofed terraces, landings, steps and ramps, not more than 1 m in height.
- (d) Except as permitted by (e) or not permitted by (f), encroachments allowed up to but not closer than 450 mm from an allotment boundary or up to but not closer than 900 mm from another building on the same allotment or associated encroachments of another building on the same allotment are—
- (i) *combustible* fascias, gutters and downpipes (see Figure 3.7.2.9); and
 - (ii) eaves with *non-combustible* roof cladding and *non-combustible* lining; and
 - (iii) flues, chimneys, pipes, domestic fuel tanks, cooling or heating appliances or other services.
- (e) Eaves with *non-combustible* roof cladding and *non-combustible* soffit or lining may encroach within 450 mm of the allotment boundary where the *external walls* of a building are located not less than 900 mm from the allotment boundary and the walls are positioned at an angle of not less than 20 degrees and not more than 70 degrees to the allotment boundary or other building and the eaves only encroach at the corner of the roof (see SA Figure 3.7.2.9a).
- (f) Fascias listed in (d)(i), must not be built within 3 m of a *brush fence*.

Figure SA 3.7.2.9a

Concession for encroachment of eaves

Figure SA 3.7.2.9a
Concession for encroachment of eaves

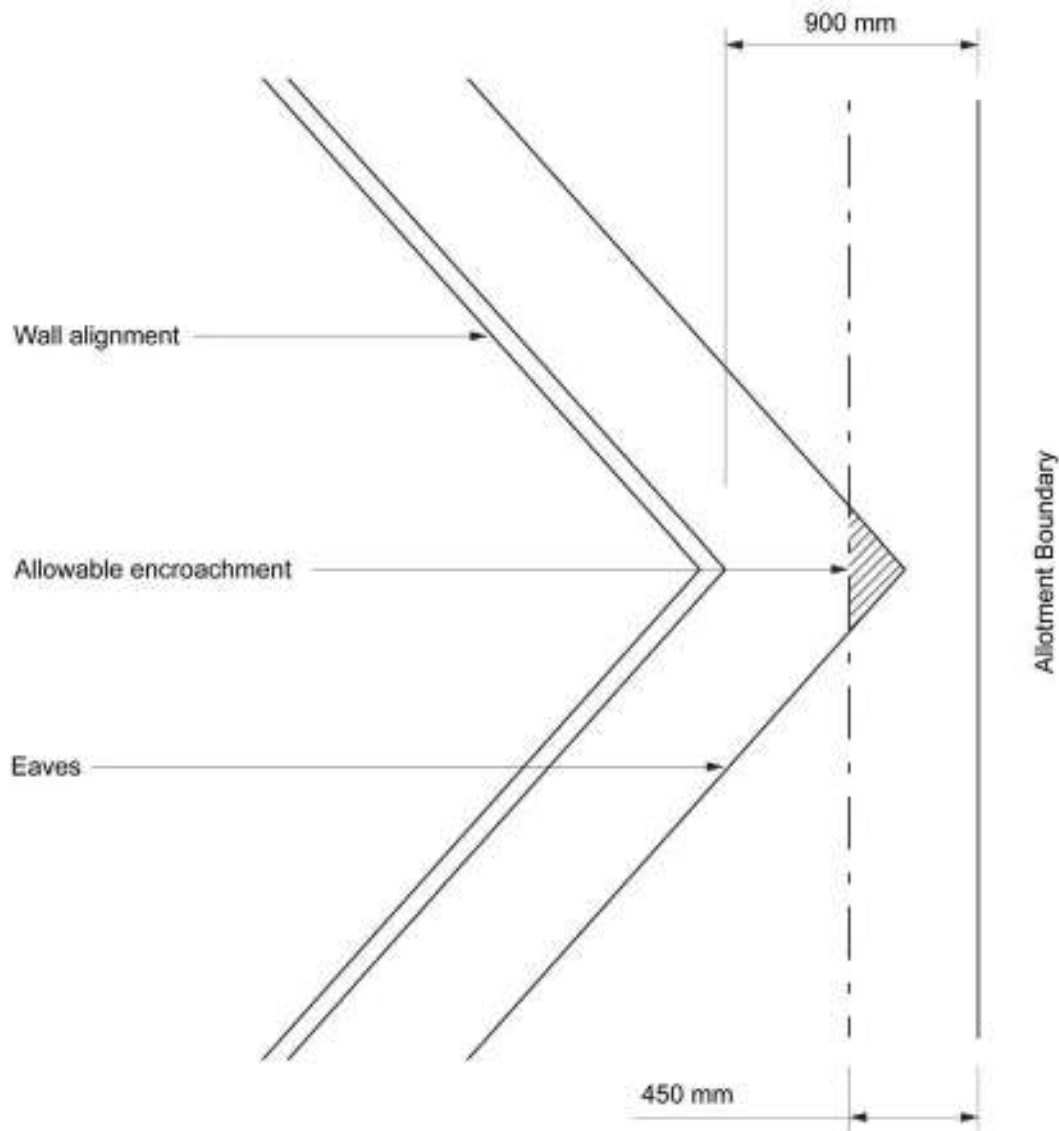

3.7.2.8 Roof lights

Combustible roof lights, skylights or the like installed in a roof or part of a roof *required* to have a *non-combustible* covering must—

- (a) have an aggregate area not more than 20% of the roof or part of the roof; and
- (b) be not less than—
 - (i) 900 mm from a separating wall or the allotment boundary, other than the boundary adjoining a road alignment or other public space; and
 - (ii) 1.8 m from any roof light or the like in another building on the allotment other than an associated building or a detached part of the same building. (See [Figure 3.7.2.10](#)).

Figure 3.7.2.10 Location of combustible roof lights

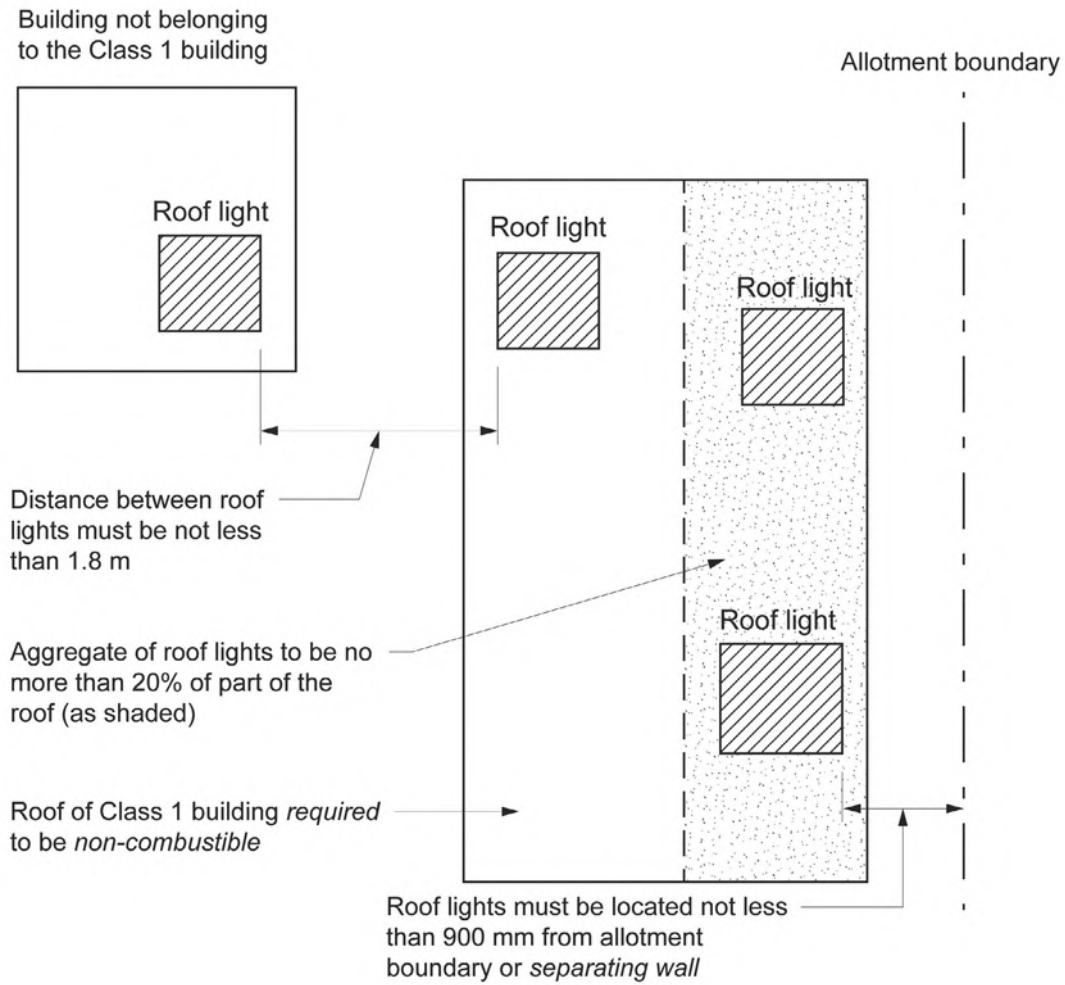

Note to Figure 3.7.2.10: Roof lights depicted in Figure 3.7.2.10 are *combustible*.

Part 3.7.3 Fire protection of separating walls and floors

Appropriate *Performance Requirements*

Where an alternative fire separation design is proposed as a *Performance Solution* to that described in [Part 3.7.3](#), that proposal must comply with—

- (a) *Performance Requirement P2.3.1*; and
- (b) the relevant *Performance Requirements* determined in accordance with [A2.2\(3\)](#) and [A2.4\(3\)](#) as applicable.

Acceptable Construction Practice

3.7.3.1 Application

Compliance with this acceptable construction practice satisfies *Performance Requirement P2.3.1* for protection of separating walls and floors.

3.7.3.2 Separating walls

- (a) A *separating wall* between Class 1 buildings, or a wall that separates a Class 1 building from a Class 10a building which is not associated with the Class 1 building must—
 - (i) have either—
 - (A) an FRL of not less than 60/60/60; or
 - (B) be of masonry construction not less than 90 mm thick; and
 - (ii) commence at the footings or ground slab (see [Figure 3.7.3.1](#)), except for horizontal projections to which [3.7.3.5](#) applies (see [Figure 3.7.3.4](#)); and
 - (iii) extend—
 - (A) if the building has a *non-combustible* roof covering, to the underside of the roof covering (see [Figure 3.7.3.1](#) and [Figure 3.7.3.2](#)); or
 - (B) if the building has a *combustible* roof covering, to not less than 450 mm above the roof covering (see [Figure 3.7.3.1](#)); and
 - (iv) comply with (b) to (e) and [3.7.3.3](#) as applicable.
- (b) A *separating wall* of *lightweight construction* must be tested in accordance with [Specification C1.8](#) of the NCC Volume One.
- (c) A *separating wall* complying with (a)(iii)(A)—
 - (i) must not be crossed by timber or other *combustible* building elements except for roof battens with dimensions of 75 x 50 mm or less, or roof sarking; and
 - (ii) must have any gap between the top of the wall and the underside of the roof covering packed with mineral fibre or other suitable *fire-resisting* material.
- (d) Where a building has a masonry veneer *external wall*, any gap between the *separating wall* and the external masonry veneer must be—
 - (i) not more than 50 mm; and
 - (ii) packed with a mineral fibre or other suitable fire resistant material with the packing arranged to maintain any weatherproofing requirements of [Part 3.3.4](#).
- (e) Eaves, verandahs and similar spaces that are open to the roof space and are common to more than one Class 1 dwelling must be separated by a *non-combustible* vertical lining (see [Figure 3.7.3.2 Diagram b](#)).

Figure 3.7.3.1 Separating wall construction

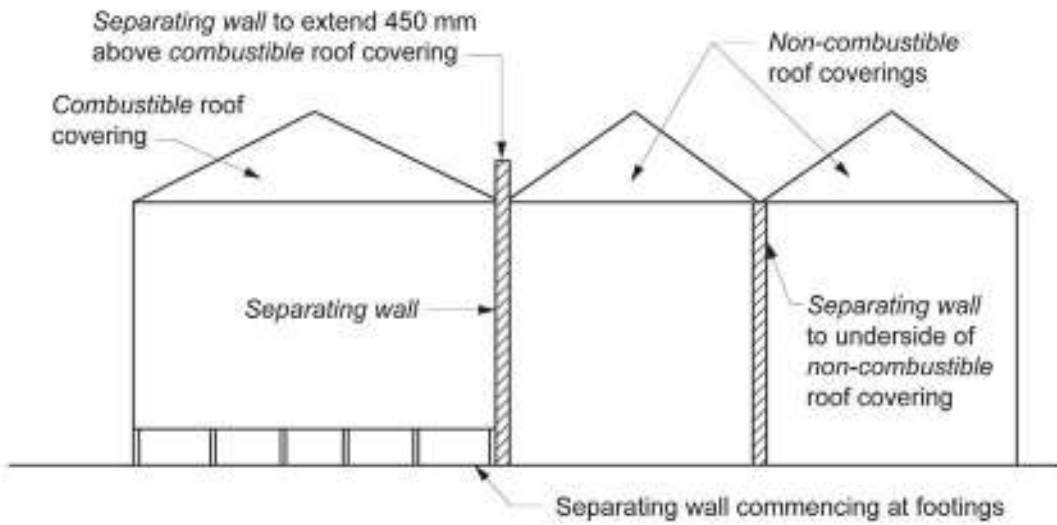

Figure 3.7.3.2 Separating wall construction—Underside of non-combustible roof cladding

Diagram a.

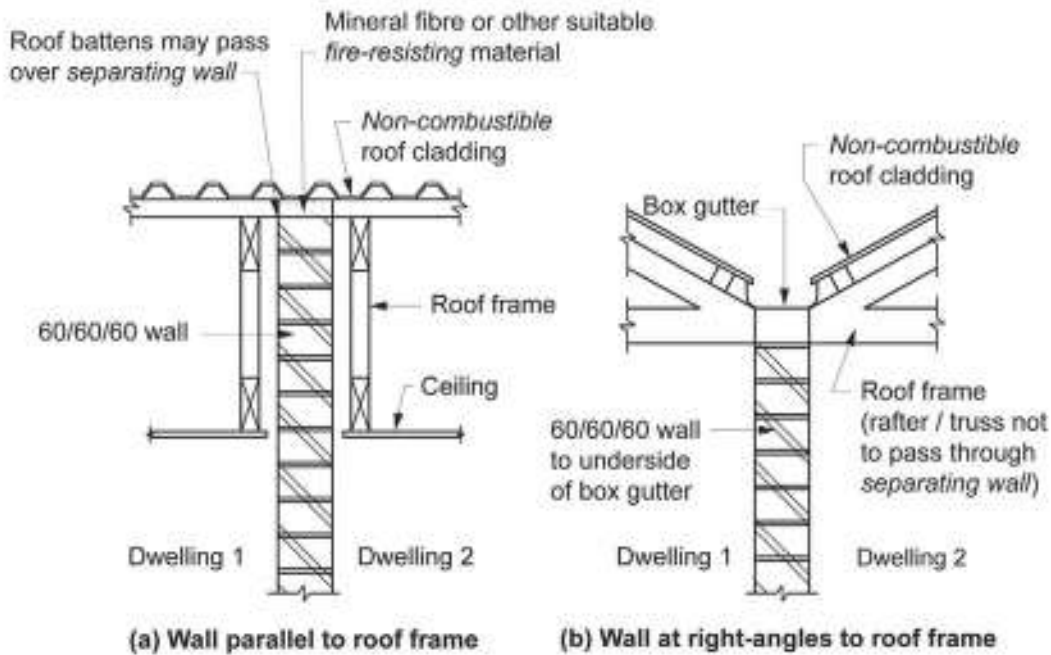
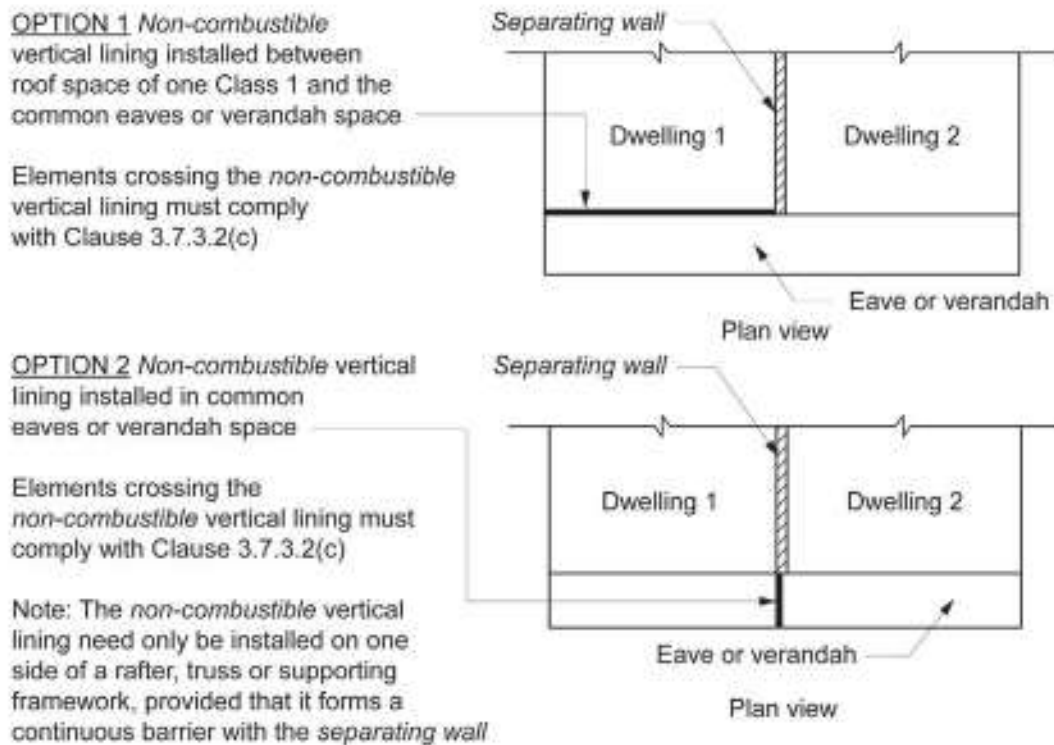

Diagram b



3.7.3.3 Services in separating walls

- (a) Any service opening, other than those listed in (b), (c) and (d), in a *separating wall* must have construction with an FRL of not less than -/60/60.
- (b) If an electrical wire or cable penetrates a *separating wall*—
- (i) the service and building element at the penetration must—
 - (A) be identical with a prototype assembly that has been tested in accordance with AS 4072.1 and AS 1530.4 and achieve an FRL of not less than -/60/60; or
 - (B) differ from a prototype assembly of the service and building element in accordance with AS 4072.1; or
 - (ii) the service must be installed so that—
 - (A) the opening is neatly formed, cut or drilled and no closer than 50 mm to any other service; and
 - (B) the opening is no larger in cross-section than—
 - (aa) 2000 mm² if only a single cable is accommodated and the gap between the cable and the wall is no wider than 15 mm; or
 - (bb) 500 mm² in any other case; and
 - (C) any gap between the service and the wall is packed with mineral fibre or other suitable fire resistant material.
- (c) If an electrical switch, outlet, socket or the like is accommodated in a *separating wall*—
- (i) the service and building element at the penetration must—
 - (A) be identical with a prototype assembly which has been tested in accordance with AS 4072.1 and AS 1530.4 and achieve an FRL of not less than -/60/60; or
 - (B) differ from a prototype assembly of the service and building element in accordance with AS 4072.1; or
 - (ii) the service must be installed so that—
 - (A) the opening or recess—

Fire Safety

- (aa) is not located opposite any point within 300 mm horizontally or 600 mm vertically of any opening or recess on the opposite side of the wall; or
 - (bb) does not extend beyond half the thickness of the wall; and
 - (B) any gap between the service and the wall is packed with mineral fibre or other suitable fire resistant material.
- (d) Other than where a tested system is used in accordance with (c)(i), if an electrical switch, socket, outlet or the like is accommodated in a hollow *separating wall*, the cavity immediately behind the service must be framed and packed with mineral fibre or other suitable fire resistant material (see Figure 3.7.3.3).

Explanatory information:

For the purposes of 3.7.3.3 and 3.8.6.5, a reference to a *separating wall* includes a wall that separates a Class 1 building from a Class 10a building that is not associated with the Class 1 building.

It is important that any opening in a *separating wall* between Class 1 buildings does not allow the free passage of fire between buildings. Many designs would require the installation of openings for electrical cables and outlets in these walls. 3.7.3.3 therefore allows such openings provided they comply with the requirements of that provision.

A reference to a hollow *separating wall* in 3.7.3.3(d) may include a stud wall, masonry *cavity* wall or a wall of hollow blockwork.

Part 3.8.6 (sound insulation) also contains requirements relevant to *separating walls*, in addition to the provisions of this Part. This includes installation requirements for walls and services to achieve appropriate levels of sound insulation.

Figure 3.7.3.3 Separating wall construction—Services in cavity construction

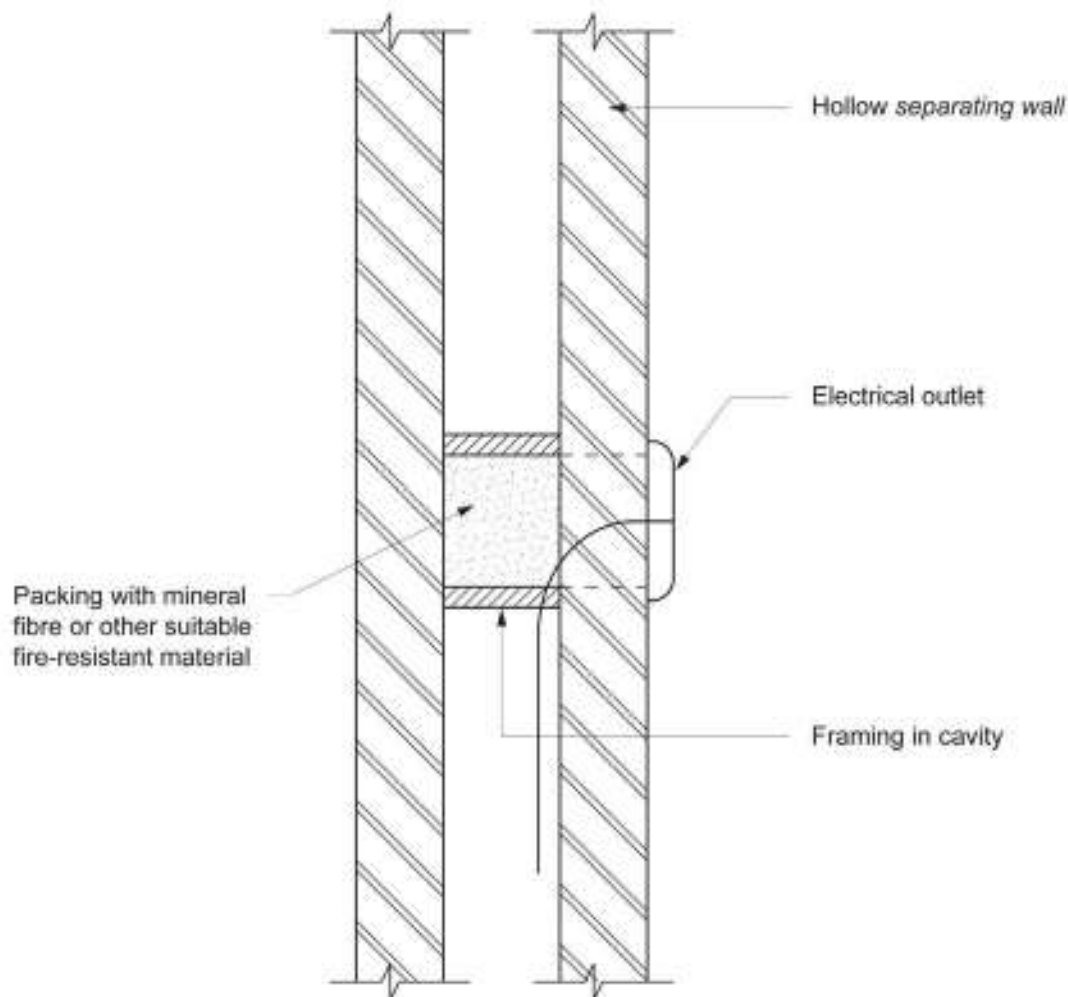

3.7.3.4 Roof lights

Combustible roof lights, skylights or the like installed in a roof or part of a roof *required* to have a *non-combustible* covering must—

- (a) have an aggregate area not more than 20% of the roof or part of the roof; and
- (b) be not less than 900 mm from the vertical projection of a *separating wall* extending to the underside of the roof covering.

3.7.3.5 Horizontal projections

- (a) Where a horizontal projection forms part of a *separating wall* complying with 3.7.3.2, any horizontal projection within 1.8 m on each side of the *separating wall* (see *Figure 3.7.3.4*) must—
 - (i) be a floor/ceiling or floor/soffit system incorporating a ceiling or soffit which has a *resistance to the incipient spread of fire* to the space above itself of not less than 60 minutes; or
 - (ii) have an FRL not less than 30/30/30 when tested from the underside; or
 - (iii) have a fire-protective covering on the underside of the floor, including beams incorporated in it, if the floor is *combustible* or of metal.
- (b) The part of the *separating wall* that projects outwards horizontally must—
 - (i) extend to the underside of the floor/ceiling or floor/soffit system complying with (a); and
 - (ii) not be crossed by timber or other *combustible* building elements except for framing members with dimensions of 75 x 50 mm or less, or sarking; and
 - (iii) have any gap between the bottom of the wall and the underside of the floor/ceiling or floor/soffit system packed with mineral fibre or other suitable *fire-resisting* material.
- (c) Where a floor subject to (a)(ii) depends on direct vertical or lateral support from another part to maintain its FRL, that supporting part must have an FRL of not less than 30/-/-.
- (d) Where a service passes through a floor referred to in (a), the penetration must not reduce the fire performance of the floor or covering.

Figure 3.7.3.4 Horizontal projection forming part of a separating wall

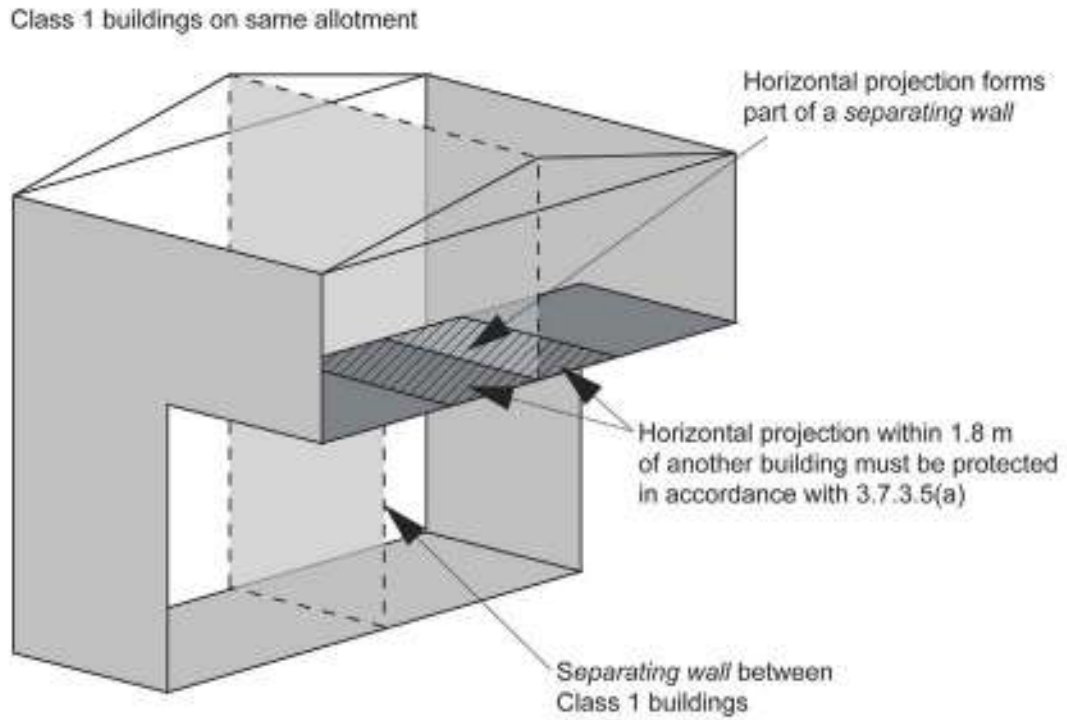

Part 3.7.4 Fire separation of garage top dwellings

Appropriate *Performance Requirements*

Where an alternative fire separation design is proposed as a *Performance Solution* to that described in [Part 3.7.4](#), that proposal must comply with—

- (a) *Performance Requirement P2.3.1*; and
- (b) the relevant *Performance Requirements* determined in accordance with [A2.2\(3\)](#) and [A2.4\(3\)](#) as applicable.

State and Territory Variations

In New South Wales, [Part 3.7.4](#) does not apply.

Note: The New South Wales Additions contain requirements for a Class 1a dwelling located above a Class 10a *private garage* that is not associated with the Class 1a dwelling.

Acceptable Construction Practice

3.7.4.1 Application

Compliance with this acceptable construction practice satisfies *Performance Requirement P2.3.1* for fire separation of garage top dwellings.

3.7.4.2 Walls requiring protection

- (a) Where parts of a Class 1a dwelling are located above a Class 10a *private garage* that is not associated with the Class 1a dwelling—
 - (i) any wall separating parts of the Class 1a dwelling from the *private garage* not associated with the dwelling must comply with (b); and
 - (ii) any *private garage* associated with and located below the Class 1a dwelling must be separated from the *private garage* not associated with the dwelling by a wall complying with (b).
- (b) A wall *required* by (a) must—
 - (i) have either—
 - (A) an FRL of not less than 60/60/60 when tested from the *private garage* associated with another dwelling side; or
 - (B) be of masonry construction not less than 90 mm thick; and
 - (ii) commence at the footings or ground slab; and
 - (iii) extend to the underside of a separating floor complying with [3.7.4.3](#); and
 - (iv) comply with [3.7.3.2\(b\)](#) to (e) and [3.7.3.3](#) as applicable.

3.7.4.3 Separating floors

- (a) Where parts of a Class 1a dwelling are located above or below a Class 10a *private garage* that is not associated with the Class 1a dwelling, any floor separating the Class 1a dwelling from the Class 10a *private garage* not associated with the dwelling must—
 - (i) be a floor/ceiling or floor/soffit system incorporating a ceiling or soffit which has a *resistance to the incipient spread of fire* to the space above itself of not less than 60 minutes; or
 - (ii) have an FRL not less than 30/30/30 when tested from the underside; or
 - (iii) have a *fire-protective covering* on the underside of the floor, including beams incorporated in it, if the floor is *combustible* or of metal.
- (b) Where a floor subject to (a)(ii) depends on direct vertical or lateral support from another part to maintain its FRL, that supporting part must have an FRL of not less than 30/-/-.
- (c) Where a service passes through a floor referred to in (a), the penetration must not reduce the fire performance of

Fire Safety

the floor or covering.

(See [Figure 3.7.4.1](#))

Figure 3.7.4.1 Separating wall and floor construction

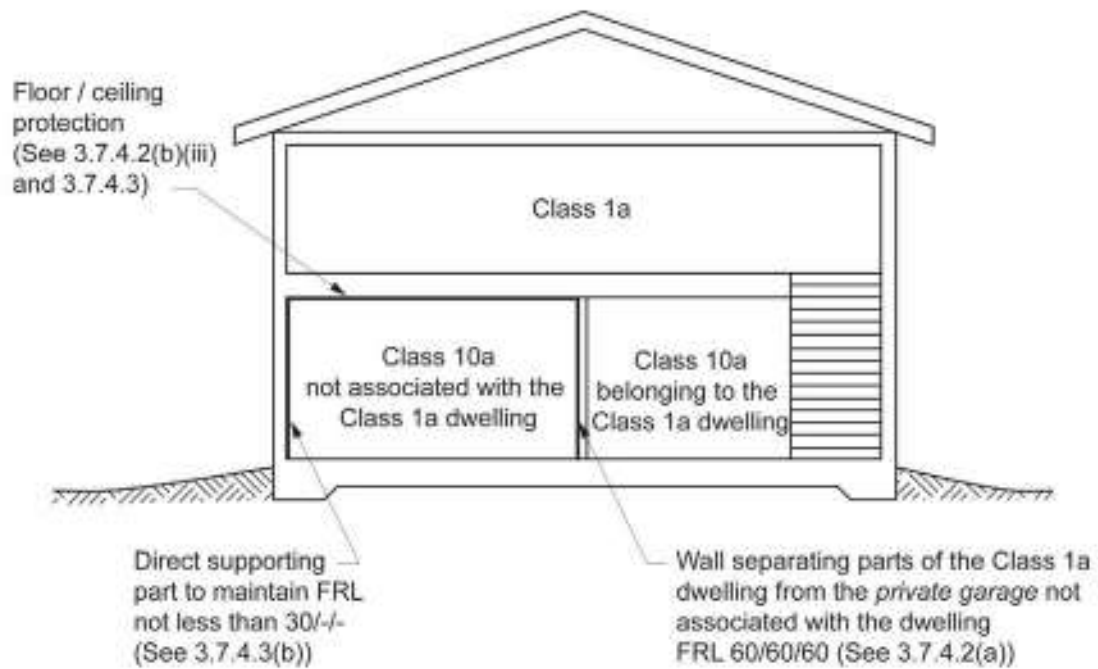

Part 3.7.5 Smoke alarms and evacuation lighting

Appropriate *Performance Requirements*

Where an alternative smoke alarm or lighting to assist evacuation system is proposed as a *Performance Solution* to that described in [Part 3.7.5](#), that proposal must comply with—

- (a) *Performance Requirement P2.3.2*; and
- (b) the relevant *Performance Requirements* determined in accordance with [A2.2\(3\)](#) and [A2.4\(3\)](#) as applicable.

Acceptable Construction Practice

3.7.5.1 Application

- (a) Compliance with this acceptable construction practice satisfies *Performance Requirement P2.3.2* for smoke alarms.
- (b) For the purposes of this Part, a Class 1 building includes a Class 10a *private garage* located above or below the Class 1 building.

3.7.5.2 Smoke alarm requirements

Smoke alarms must—

- (a) be located in—
 - (i) Class 1a buildings in accordance with [3.7.5.3](#) and [3.7.5.5](#); and
 - (ii) Class 1b buildings in accordance with [3.7.5.4](#) and [3.7.5.5](#).
- (b) comply with AS 3786, except that in a Class 10a *private garage* where the use of the area is likely to result in smoke alarms causing spurious signals, any other alarm deemed suitable in accordance with AS 1670.1 may be installed provided that smoke alarms complying with AS 3786 are installed elsewhere in the Class 1 building; and
- (c) be powered from the consumer mains source where a consumer mains source is supplied to the building; and
- (d) be interconnected where there is more than one alarm.

Explanatory information:

A smoke alarm can give spurious alarms if the atmosphere contains particles which obscure vision, such as could occur in a Class 10a *private garage* part of a building. [3.7.5.2\(b\)](#) therefore allows the use of a more suitable alarm, such as a heat alarm, in these locations.

[3.7.5.2\(d\)](#) requires alarms to be interconnected where there is more than one alarm. This only applies within a single dwelling. Therefore, alarms in a Class 1a dwelling need not be interconnected with alarms in another dwelling or a *private garage* which does not belong to the Class 1a dwelling.

State and Territory Variations

In New South Wales delete 3.7.5.2 insert NSW 3.7.5.2 as follows:

- (a) Smoke alarms must—
 - (i) be located in—
 - (A) Class 1a buildings, excluding any non associated Class 10a *private garages*, subject to (b), in accordance with [3.7.5.3](#) and [3.7.5.5](#); and
 - (B) Class 1b buildings in accordance with [3.7.5.4](#) and [3.7.5.5](#); and
 - (ii) comply with AS 3786, except that in a Class 10a *private garage* where the use of the area is likely to result in smoke alarms causing spurious signals, any other alarm deemed suitable in accordance with AS 1670.1 may be installed provided that smoke alarms complying AS 3786 are installed elsewhere in the Class 1 building; and
 - (iii) be connected to the consumer mains power where consumer power is supplied to the building; and
 - (iv) be interconnected where there is more than one alarm.
- (b) Heat alarms must be installed in a Class 10a *private garage* that is located beneath a Class 1a dwelling and not

Fire Safety

associated with that dwelling, in accordance with [NSW 1.1.4](#).

Explanatory information:

A smoke alarm can give spurious alarms if the atmosphere contains particles which obscure vision, such as could occur in a Class 10a *private garage* part of a building. [NSW 3.7.5.2\(a\)\(ii\)](#) therefore allows the use of a more suitable alarm, such as a heat alarm, in these locations.

Where a Class 10a *private garage* is located beneath a Class 1a dwelling and is not associated with that dwelling, [NSW 3.7.5.2\(b\)](#) requires a heat alarm to be provided in the non-associated Class 10a *private garage* in accordance with [NSW 1.1.4](#) in the NSW Additions. The NSW Addition also contains requirements for the interconnection of alarms and the provision of durable notices.

[NSW 3.7.5.2\(a\)\(iv\)](#) requires alarms to be interconnected where there is more than one alarm. This only applies within a single dwelling. Therefore alarms in a Class 1a dwelling need not be interconnected with alarms in another dwelling.

3.7.5.3 Location — Class 1a buildings

In a Class 1a building, smoke alarms must be located in—

(a) any storey containing bedrooms, every corridor or hallway associated with a bedroom, or if there is no corridor or hallway, in an area between the bedrooms and the remainder of the building; and

(b) each other storey not containing bedrooms.

(see [Figure 3.7.5.1, Diagram a and b](#))

3.7.5.4 Location — Class 1b buildings

In a Class 1b building, smoke alarms must be located in—

(a) every bedroom; and

(b) every corridor or hallway associated with a bedroom, or if there is no corridor or hallway, in an area between the bedrooms and the remainder of the building; and

(c) each other storey.

(see [Figure 3.7.5.1, Diagram c](#))

Figure 3.7.5.1

Diagram a Class 1a building where all bedrooms are grouped together and served by a hallway

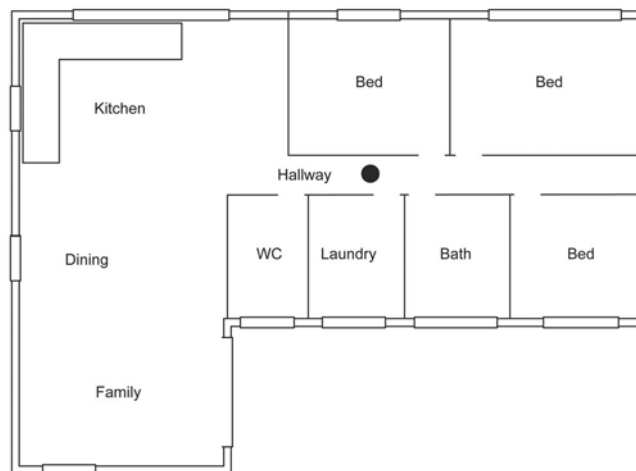

Legend for [Figure 3.7.5.1 Diagram a](#):

- Smoke alarm

Fire Safety

Diagram b Class 1a building where bedrooms are located in separate areas

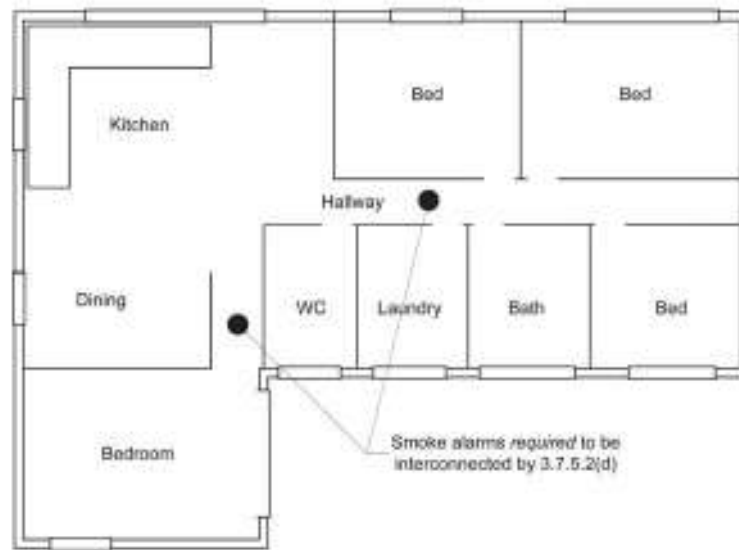

Legend for [Figure 3.7.5.1 Diagram b](#):

- Smoke alarm

Diagram c Class 1b building where multiple bedrooms are served by a hallway

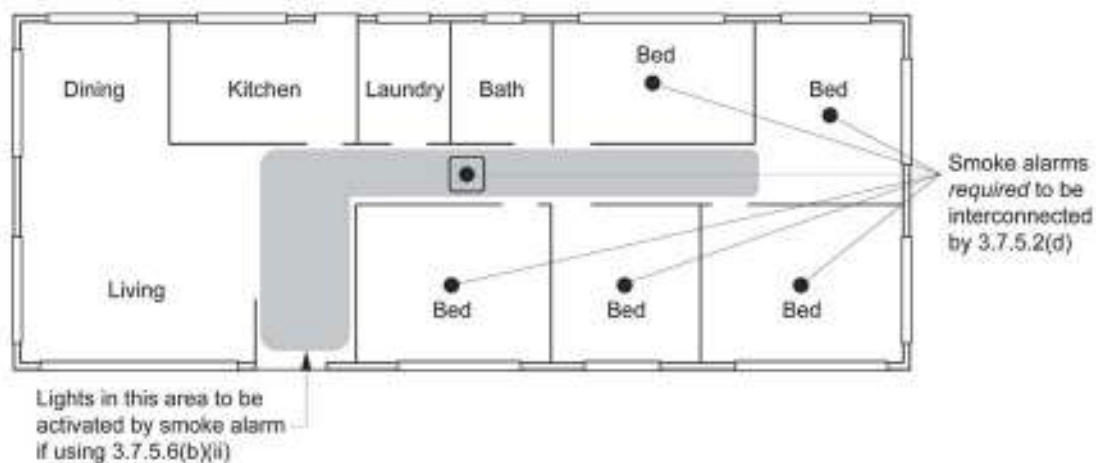

Legend for [Figure 3.7.5.1 Diagram c](#):

- Smoke alarm
- ◻ Smoke alarm with evacuation lighting (as *required* by [3.7.5.6\(b\)\(i\)](#))

3.7.5.5 Installation of smoke alarms

Smoke alarms *required* by [3.7.5.3](#) and [3.7.5.4](#) must be installed on or near the ceiling, in accordance with the following:

- (a) Where a smoke alarm is located on the ceiling it must be—
 - (i) a minimum of 300 mm away from the corner junction of the wall and ceiling; and
 - (ii) between 500 mm and 1500 mm away from the high point and apexes of the ceiling, if the room has a sloping ceiling.
- (b) Where (a) is not possible, the smoke alarm may be installed on the wall, and located a minimum of 300 mm and a maximum of 500 mm off the ceiling at the junction with the wall.

Explanatory information:

Smoke alarms need to be located on (or near) the ceiling for optimum detection of smoke in a fire situation with special care taken to avoid dead air spaces. A dead air space is an area in which trapped hot air will prevent smoke from reaching the alarm. This space generally occurs at the apex of cathedral ceilings, the corner junction of walls and ceilings and between exposed joists etc. (see diagram 1).

Smoke alarms may be located on the wall in accordance with 3.7.5.5(b). Diagram 1 provides location criteria and the dimensional relationship to building elements and the associated dead air spaces.

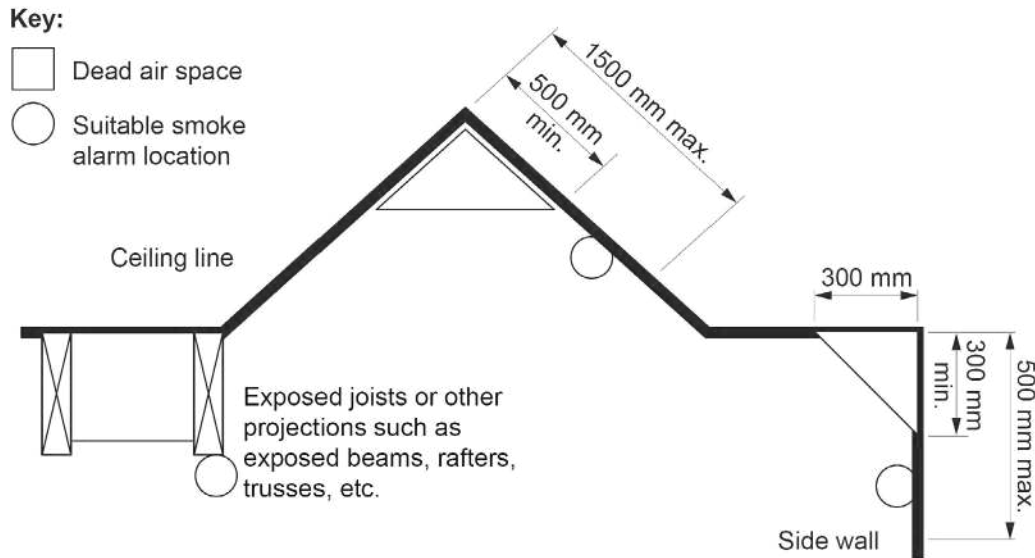

Diagram 1 – Installation of smoke alarms to avoid dead air space

3.7.5.6 Lighting to assist evacuation — Class 1b buildings

In a Class 1b building, a system of lighting must be installed to assist evacuation of occupants in the event of a fire, and—

- (a) be activated by the smoke alarm *required* by 3.7.5.4(b); and
- (b) consist of—
 - (i) a light incorporated within the smoke alarm; or
 - (ii) the lighting located in the corridor, hallway or area served by the smoke alarm.

Explanatory information:

The lighting *required* by 3.7.5.6 may consist of artificial lighting which may already be installed in a corridor, hallway or area, provided that the lighting is activated by the smoke alarm. However consideration should be given to ensure that the lighting is not controlled by a dimmer or timer controlled switch which may dim the level of light to an ineffective level, or switch the light off before occupants have time to evacuate.

1. Smoke alarms general requirements:

Performance Requirement P2.3.2 and the *Deemed-to-Satisfy Provisions* of this Part require automatic warning on the detection of smoke in buildings, so that occupants may be alerted to a fire in order to evacuate to a place of safety.

2. Different smoke alarm requirements for Class 1a and Class 1b buildings:

Part 3.7.5 specifies different smoke alarm requirements for Class 1a and Class 1b buildings. The main difference is that a Class 1b building is *required* to have a greater number of smoke alarms, i.e. smoke alarms must be installed in all bedrooms, and a system of lighting must be installed to assist evacuation. This is due to Class 1b buildings generally being used for more transient purposes and the occupants being less familiar with the building layout.

3. Smoke alarms complying with AS 3786:

3.7.5.2(b) requires a smoke alarm(s) to comply with AS 3786. AS 3786 contains the requirements for the design and performance of electrically operated smoke alarms containing both detection and alarm facilities. Types of smoke alarms prescribed in AS 3786 include photoelectric, ionisation or a combination of the two.

4. Smoke alarms to be connected to consumer mains source:

3.7.5.2(c) requires that a smoke alarm be connected to the consumer mains electricity source where a consumer mains source is supplied to the building. A smoke alarm complying with AS 3786, that is intended for connection to an external power source, is *required* to be provided with a secondary power source i.e. a source of power to supply the smoke alarm in the event that the primary power source is unavailable. Generally, the requirement is met by providing mains powered smoke alarms with a battery back up.

5. Interconnection of smoke alarms:

3.7.5.2(d) requires that alarms be interconnected to provide a common alarm so that if one alarm in the dwelling activates, the other alarms automatically activate, which will increase the likelihood of sleeping occupants becoming aware of the detection of smoke. Alarms of a Class 1 building need not be interconnected with alarms in another Class 1 building or a *private garage* which does not belong to the Class 1 building.

6. Location of smoke alarms:

When deciding on the position of smoke alarms it is important to remember that they are intended to detect smoke before it reaches the sleeping occupants of a building.

The ensuing alarm is designed to wake the occupants and give them time to evacuate the building.

7. Smoke alarms required on other storeys not containing bedrooms:

In addition to a smoke alarm being *required* to be provided on storeys containing bedrooms, a smoke alarm is also *required* on each other storey that is not already provided with a smoke alarm even if those storeys consist of only carparking, bathrooms, laundries and the like. "Storey" in this context differs from the definition contained in NCC Volume One which excludes such spaces from being considered as storeys.

Reference to "storey" only applies within a single dwelling. For example, if a storey contains a *private garage* belonging to the Class 1a dwelling in addition to a *private garage* which does not belong to the Class 1a dwelling, smoke alarms must be installed in both *private garages*.

Where the other storey is a Class 10a *private garage*, 3.7.5.2(b) permits the use of any other alarm deemed suitable in accordance with AS 1670.1 provided smoke alarms complying with AS 3786 are installed elsewhere in the Class 1 building.

8. Nuisance alarms:

Smoke alarms are extremely sensitive and may detect smoke and moisture created by common household activities such as burnt toast or steam from a bathroom.

Accordingly, to reduce the likelihood of nuisance alarms, it is preferable that smoke alarms are not located near cooking appliances and bathrooms. However, if it is necessary to locate alarms in these positions, the type of alarm installed may need to be considered as some alarm types may be more suitable in certain locations.

9. Added flexibility when considering smoke alarm location:

The options described in *Deemed-to-Satisfy Provisions* are not the only means available for complying with the *Housing Provisions*. The performance nature of the NCC provides flexibility to develop alternative methods if it is preferred to meet the *Performance Requirement* in some other way. This added flexibility may be utilised when considering the location of smoke alarms.

Health and Amenity

- Part 3.8.1** **Wet areas and external waterproofing**
- Part 3.8.2** **Room heights**
- Part 3.8.3** **Facilities**
- Part 3.8.4** **Light**
- Part 3.8.5** **Ventilation**
- Part 3.8.6** **Sound insulation**
- Part 3.8.7** **Condensation management**

Part 3.8 Health and Amenity

Part 3.8.1 Wet areas and external waterproofing

Acceptable Construction Practice

- 3.8.1.1 Application
- 3.8.1.2 Wet Areas
- 3.8.1.3 External above ground membranes

Part 3.8.2 Room heights

Acceptable Construction Practice

- 3.8.2.1 Application
- 3.8.2.2 Height of rooms and other spaces

Part 3.8.3 Facilities

Acceptable Construction Practice

- 3.8.3.1 Application
- 3.8.3.2 Required facilities
- 3.8.3.3 Construction of sanitary compartments

Part 3.8.4 Light

Acceptable Construction Practice

- 3.8.4.1 Application
- 3.8.4.2 Natural light
- 3.8.4.3 Artificial lighting

Part 3.8.5 Ventilation

Acceptable Construction Manual

- 3.8.5.0 Application

Acceptable Construction Practice

- 3.8.5.1 Application
- 3.8.5.2 Ventilation requirements
- 3.8.5.3 Location of sanitary compartments

Part 3.8.6 Sound insulation

Acceptable Construction Practice

- 3.8.6.1 Application
- 3.8.6.2 Sound insulation requirements
- 3.8.6.3 Determination of airborne sound insulation ratings
- 3.8.6.4 Construction of sound insulated walls
- 3.8.6.5 Services

Part 3.8.7 Condensation management

Acceptable Construction Practice

- 3.8.7.1 Application
- 3.8.7.2 Pliable building membrane
- 3.8.7.3 Flow rate and discharge of exhaust systems
- 3.8.7.4 Ventilation of roof spaces

Part 3.8.1 Wet areas and external waterproofing

Appropriate *Performance Requirements*

- (a) Where an alternative system for external *waterproofing* a roof or external wall of a building is proposed as a *Performance Solution* to that described in [Part 3.8.1](#), that proposal must comply with—
 - (i) *Performance Requirement P2.2.2*; and
 - (ii) the relevant *Performance Requirements* determined in accordance with [A2.4\(3\)](#).
- (b) Where an alternative system for protecting *wet areas* in a building is proposed as a *Performance Solution* to that described in [Part 3.8.1](#), that proposal must comply with—
 - (i) *Performance Requirement P2.4.1*; and
 - (ii) the relevant *Performance Requirements* determined in accordance with [A2.2\(3\)](#) and [A2.4\(3\)](#) as applicable.

Acceptable Construction Practice

3.8.1.1 Application

Compliance with this acceptable construction practice satisfies *Performance Requirements P2.2.2* for external *waterproofing* and *P2.4.1* for *wet areas*.

3.8.1.2 Wet Areas

Building elements in *wet areas* within a building must—

- (a) be *waterproof* or *water resistant* in accordance with [Table 3.8.1.1](#); and
- (b) comply with AS 3740.

Table 3.8.1.1 Waterproofing and water resistance requirements for building elements in wet areas

<i>Vessels</i> or area where the fixture is installed	Floors and horizontal surfaces	Walls	Wall junctions and joints	Wall / floor junctions	Penetrations
Shower area (enclosed and unenclosed)					
With hob	<i>Waterproof</i> floor in <i>shower area</i> (including any hob or step-down)	(a) <i>Waterproof</i> all walls in <i>shower area</i> to a height the greater of—	<i>Waterproof</i> wall junctions within <i>shower area</i> .	<i>Waterproof</i> wall / floor junctions within <i>shower area</i> .	<i>Waterproof</i> penetrations in <i>shower area</i> .
With step-down		(i) not less than 150 mm above floor substrate; or			
Without hob or step-down		(ii) not less than 25 mm above maximum retained water level; and			
		(b) <i>Water resistant</i> walls in <i>shower area</i> to not less than 1800 mm above finished floor level of the			

Health and Amenity

Vessels or area where the fixture is installed	Floors and horizontal surfaces	Walls	Wall junctions and joints	Wall / floor junctions	Penetrations
		shower.			
With preformed shower base	N/A	<i>Water resistant</i> walls in <i>shower area</i> to not less than 1800 mm above finished floor level of the show.	<i>Waterproof</i> wall junctions within <i>shower area</i> .	<i>Waterproof</i> wall / floor junctions within <i>shower area</i> .	<i>Waterproof</i> penetrations in <i>shower area</i> .
Area outside shower area					
For concrete and compressed fibre-cement sheet flooring	<i>Water resistant</i> floor of the room.				
For timber floors including particleboard, plywood and other timber based flooring materials	<i>Waterproof</i> floor of the room	N/A	N/A	<i>Waterproof</i> wall / floor junctions	N/A
Areas adjacent to baths and spas					
For concrete and compressed fibre-cement sheet flooring	<i>Water resistant</i> floor of the room.	(a) <i>Water resistant</i> to a height of not less than 150 mm above the <i>vessel</i> , for the extent of the <i>vessel</i> , where the <i>vessel</i> is within 75 mm of a wall. (b) <i>Water resistant</i> all exposed surfaces below <i>vessel</i> lip.	<i>Water resistant</i> junctions within 150 mm above a <i>vessel</i> for the extent of the <i>vessel</i> .	<i>Water resistant</i> wall / floor junctions for the extent of the <i>vessel</i> .	<i>Waterproof</i> tap and spout penetrations where they occur in horizontal surfaces.
For timber floors including particleboard, plywood and other timber based flooring materials	<i>Waterproof</i> floor of the room.	(a) <i>Water resistant</i> to a height of not less than 150 mm above the <i>vessel</i> , for the extent of the <i>vessel</i> , where the <i>vessel</i> is within 75 mm of a wall. (b) <i>Water resistant</i> all exposed surfaces below <i>vessel</i> lip.	<i>Water resistant</i> junctions within 150 mm above a <i>vessel</i> for the extent of the <i>vessel</i> .	<i>Water resistant</i> wall / floor junctions for the extent of the <i>vessel</i> .	<i>Waterproof</i> tap and spout penetrations where they occur in horizontal surfaces.
Inserted baths and spas	(a) <i>Waterproof</i> shelf area, incorporating waterstop under the bath lip. (b) No	(a) <i>Waterproof</i> to not less than 150 mm above the lip of the bath or spa; and (b) No requirement under bath.	(a) <i>Waterproof</i> junctions within 150 mm above bath or spa; and (b) No	N/A	<i>Waterproof</i> tap and spout penetrations where they occur in horizontal surfaces.

Health and Amenity

Vessels or area where the fixture is installed	Floors and horizontal surfaces	Walls	Wall junctions and joints	Wall / floor junctions	Penetrations
	requirement under bath.		requirement under bath		
Other areas					
Laundries and WCs	<i>Water resistant</i> floor of the room	N/A	N/A	<i>Water resistant</i> wall / floor junctions.	N/A
Walls adjoining other <i>vessels</i> (e.g. sink, basin or laundry tub)	N/A	<i>Water resistant</i> to a height of not less than 150 mm above the <i>vessel</i> , for the extent of the <i>vessel</i> , where the <i>vessel</i> is within 75 mm of a wall.	<i>Waterproof</i> wall junctions where a <i>vessel</i> is fixed to a wall.	N/A	<i>Waterproof</i> tap and spout penetrations where they occur in surfaces <i>required</i> to be <i>waterproof</i> or <i>water resistant</i> .

Notes to Table 3.8.1.1:

1. N/A means not applicable.
2. Where a shower is above a bath or spa, use requirements for shower.

State and Territory variations**In South Australia delete 3.8.1.2 and insert SA 3.8.1.2 as follows:**

Building elements in *wet areas* within a building must—

- (a) be *waterproof* or *water resistant* in accordance with Table 3.8.1.1, except that—
 - (i) in any room containing a washing machine, the wall area from finished floor level to a minimum of 75 mm above and 75 mm each side of the washing machine tap outlets must be *water resistant*; and
 - (ii) where a *vessel* is inset into a bench top in a kitchen, bar area, kitchenette or domestic food and beverage preparation area—
 - (A) wall junctions and joints within 150 mm above the *vessel* must be *water resistant* for the extent of the *vessel*; and
 - (B) the perimeter edges of the *vessel* must be *water resistant* for the extent of the *vessel* (see Figure SA 3.8.1.2); and
 - (iii) penetrations in horizontal surfaces for tap and spout outlets in kitchens, bar areas, kitchenettes or domestic food and beverage preparation areas, must be *waterproof*; and
- (b) comply with AS 3740; and
- (c) have floor wastes provided in accordance with SA 3.2.2.
- (d) where floor wastes are provided for drainage of floors in bathrooms and laundries, the floors, floor/wall junction and penetration must be *waterproof*.

Figure SA 3.8.1.2

Typical water resistant junctions and joints for bench tops with inset vessels and vessels abutting walls

Figure SA 3.8.1.2

Typical water resistant junctions and joints for bench tops with inset vessels and vessels abutting walls

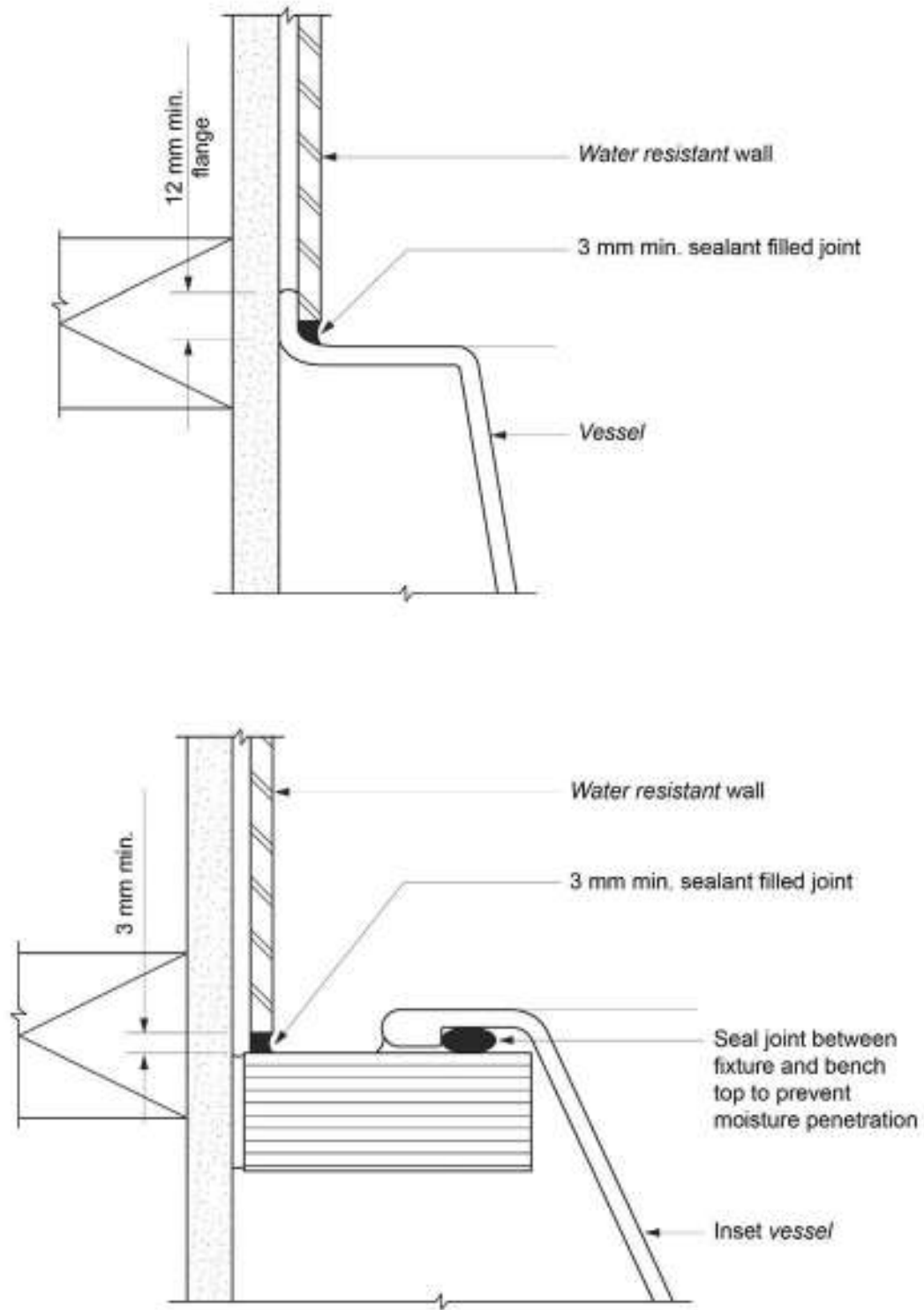
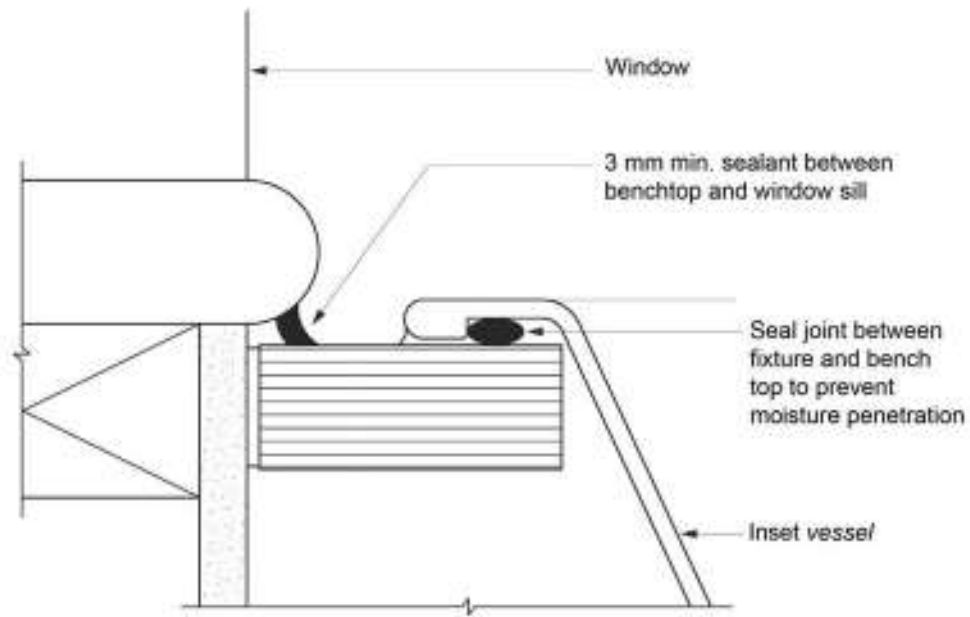

Figure SA 3.8.1.2

Typical water resistant junctions and joints for bench tops with inset vessels and vessels abutting walls



3.8.1.3 External above ground membranes

Waterproofing membranes for external above ground use must comply with AS 4654.1 and AS 4654.2.

Part 3.8.2 Room heights

Appropriate *Performance Requirements*

Where an alternative room height is proposed as a *Performance Solution* to that described in [Part 3.8.2](#), that proposal must comply with—

- (a) *Performance Requirement P2.4.2*; and
- (b) the relevant *Performance Requirements* determined in accordance with [A2.2\(3\)](#) and [A2.4\(3\)](#) as applicable.

Acceptable Construction Practice

3.8.2.1 Application

Compliance with this acceptable construction practice satisfies *Performance Requirement P2.4.2* for room heights.

3.8.2.2 Height of rooms and other spaces

Heights of rooms and other spaces (see [Figure 3.8.2.1](#)) must be not less than—

- (a) in a *habitable room* excluding a kitchen — 2.4 m; and
- (b) in a kitchen — 2.1 m; and
- (c) in a corridor, passageway or the like — 2.1 m; and
- (d) in a bathroom, shower room, laundry, *sanitary compartment*, airlock, pantry, storeroom, garage, car parking area or the like — 2.1 m; and
- (e) in a room or space with a sloping ceiling or projections below the ceiling line within—
 - (i) a *habitable room*—
 - (A) in an attic — a height of not less than 2.2 m for at least two-thirds of the *floor area* of the room or space; and
 - (B) in other rooms — a height of not less than 2.4 m over two-thirds of the *floor area* of the room or space; and
 - (ii) a non-*habitable room* — a height of not less than 2.1 m for at least two-thirds of the *floor area* of the room or space, and when calculating the *floor area* of a room or space, any part that has a ceiling height of less than 1.5 m is not included; and
- (f) in a stairway, ramp, *landing*, or the like — 2.0 m measured vertically above the nosing line of stairway treads or the floor surface of a ramp, *landing* or the like.

Explanatory information:

1. Where a room or space has no ceiling lining, the measurement is taken from the floor to the underside of the floor or roof above.
2. In areas unlikely to be occupied for long periods, such as non-*habitable rooms*, a reduced height of 2.1 m is permitted.
3. [3.8.2.2\(f\)](#) permits a reduced height of 2.0 m above stairways, ramps and landings, as these are used for transient purposes and therefore a reduction from the *required* height in corridors and rooms (2.1 and 2.4 m generally) will not adversely affect occupant safety, health or amenity.

Health and Amenity

Figure 3.8.2.1

Measurement of heights of rooms and other spaces

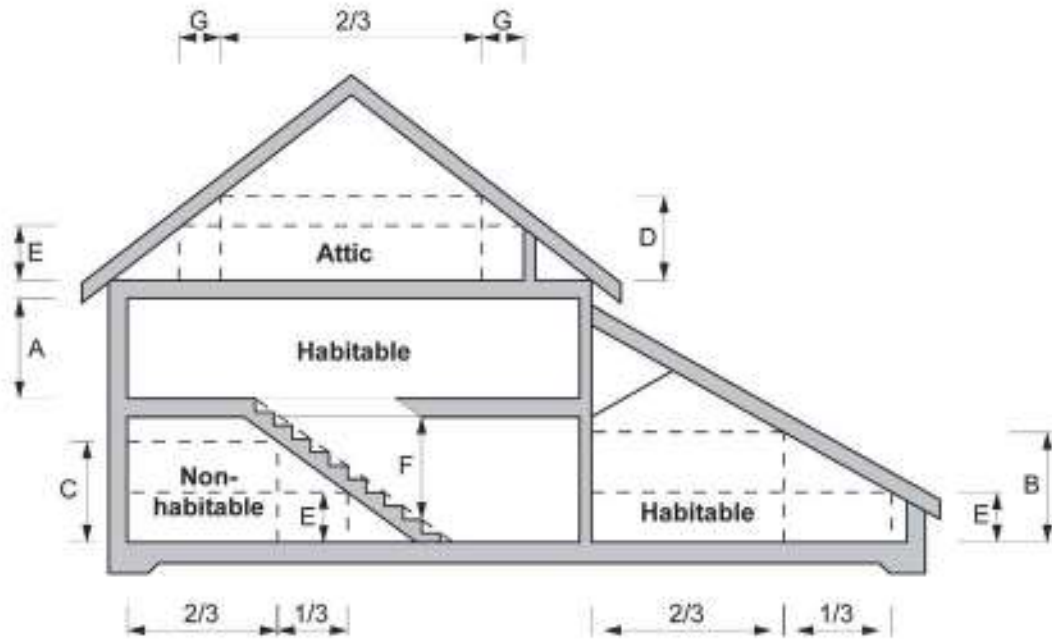

Note: The letters in the diagram represent the following minimum dimensions:

- A = 2.4 m In a *habitable room* (excluding a kitchen).
- B = 2.4 m In a *habitable room* with a sloping ceiling for at least two-thirds of the *floor area* of the room or space.
- C = 2.1 m In a non-*habitable room* with a sloping ceiling for at least two-thirds of the *floor area* of the room or space.
- D = 2.2 m In an attic with a sloping ceiling for at least two-thirds of the *floor area* of the room or space.
- E = 1.5 m For the purpose of calculating the *floor area* of a room or space, any ceiling height of less than 1.5 m is excluded.
- F = 2.0 m In a stairway (measured vertically above the nosing line).

The combined dimensions of G must not exceed one-third of the *floor area* (See E above) of the room or space.

Part 3.8.3 Facilities

Appropriate *Performance Requirements*

Where an alternative arrangement for facilities is proposed as a *Performance Solution* to that described in [Part 3.8.3](#), that proposal must comply with—

- (a) *Performance Requirement P2.4.3*; and
- (b) the relevant *Performance Requirements* determined in accordance with [A2.2\(3\)](#) and [A2.4\(3\)](#) as applicable.

Acceptable Construction Practice

3.8.3.1 Application

Compliance with this acceptable construction practice satisfies *Performance Requirement P2.4.3* for facilities.

Explanatory information:

Additional requirements relating to facilities for people with a disability in Class 1b and Class 10a buildings are contained in Volume One of the BCA. These requirements are based on the Disability (Access to Premises – Buildings) Standards (Premises Standards) which are available from the Australian Government Attorney-General's Department website at www.ag.gov.au.

3.8.3.2 Required facilities

- (a) A Class 1 building must be provided with—
 - (i) a kitchen sink and facilities for the preparation and cooking of food; and
 - (ii) a bath or shower; and
 - (iii) clothes washing facilities, comprising at least one washtub and space in the same room for a washing machine; and
 - (iv) a closet pan; and
 - (v) a washbasin.
- (b) If any of the facilities in (a) are detached from the main building, they must be set aside for the exclusive use of the occupants of the building.

Explanatory information:

1. A kitchen sink or washbasin must not be counted as a laundry washtub. A laundry washtub is considered to provide the necessary means to dispose of waste water as *required* by [P2.4.3\(c\)](#).
2. Installation requirements for certain electrical or gas cooking appliances may influence the selection of surrounding materials or the clearance to those materials.

3.8.3.3 Construction of sanitary compartments

The door to a fully enclosed *sanitary compartment* must—

- (a) open outwards; or
- (b) slide; or
- (c) be readily removable from the outside of the compartment,

unless there is a clear space of at least 1.2 m, measured in accordance with [Figure 3.8.3.3](#), between the closet pan within the *sanitary compartment* and the doorway.

Figure 3.8.3.3 Construction of sanitary compartments

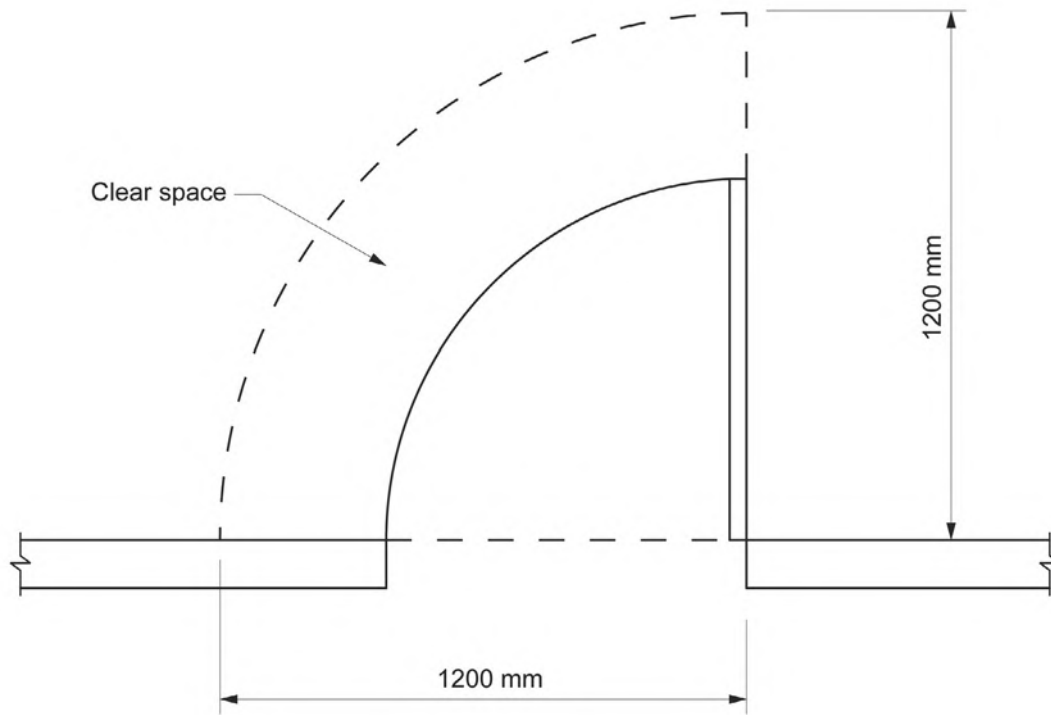
**Explanatory information:**

3.8.3.3 requires means of removing an unconscious occupant from a fully enclosed *sanitary compartment*. If the enclosure has gaps that are large enough to allow access for a person into the *sanitary compartment*, the compartment is not considered enclosed for the purpose of this clause.

State and Territory variations**Part 3.8.3.4 is added as follows in Tasmania.****Installation of closet fixtures**

- (a) If a sufficient sewerage system is not available, an authorised alternative means of disposal of sewage may be installed.
- (b) If sanitary facilities are not water-flushed, the following provisions apply.
 - (i) A pit latrine, an incinerating toilet, a chemical toilet, a removable pan or a non-flushing urinal must not be within 2 m of a building containing *habitable rooms*.
 - (ii) The floor on which a removable pan is placed must be impervious.
 - (iii) A room containing a composting toilet must be separated from *habitable rooms* by way of a permanently ventilated air lock (which may be a circulation space).
 - (iv) The minimum ventilation *required* under (iii) shall be the greater of—
 - (A) 8000 mm²; or
 - (B) 1/500th of the *floor area* of the circulation space.
 - (v) Access for maintenance or removal of waste from a composting toilet must be by way of an access door which opens directly to the outside of the building.

Explanatory information: Cross-volume considerations

NCC Volume Three contains a number of plumbing and drainage provisions which are relevant to facilities. These include, but may not be limited to, the following:

Access for maintenance of plumbing and drainage	Parts B1, B2, B3, C1 and C2
Heated water temperature control for facilities used for personal hygiene	Part B2
Installation of plumbing and drainage systems	Parts C1 and C2

Part 3.8.4 Light

Appropriate *Performance Requirements*

Where an alternative light system is proposed as a *Performance Requirement* to that described in Part 3.8.4, that proposal must comply with—

- (a) *Performance Requirement P2.4.4*; and
- (b) the relevant *Performance Requirements* determined in accordance with A2.2(3) and A2.4(3) as applicable.

Acceptable Construction Practice

3.8.4.1 Application

Compliance with this acceptable construction practice satisfies *Performance Requirement P2.4.4* for light.

3.8.4.2 Natural light

Natural light must be provided to all *habitable rooms*, in accordance with the following:

- (a) Natural light must be provided by—
 - (i) *windows*, excluding *roof lights* that—
 - (A) have an aggregate light transmitting area measured exclusive of framing members, glazing bars or other obstructions of not less than 10% of the *floor area* of the room; and
 - (B) are open to the sky or face a court or other space open to the sky or an open verandah, carport or the like; or
 - (ii) *roof lights* that—
 - (A) have an aggregate light transmitting area measured exclusive of framing members, glazing bars or other obstructions of not less than 3% of the *floor area* of the room; and
 - (B) are open to the sky; or
 - (iii) a proportional combination of *windows* and *roof lights required* by (i) and (ii).

Explanatory information:

A *roof light* generally receives greater exposure to sunlight than a *window* because of its orientation to the sky and consequently, the size of a *roof light* as a percentage of the *floor area* served is permitted to be smaller than for a *window* serving the same *floor area*.

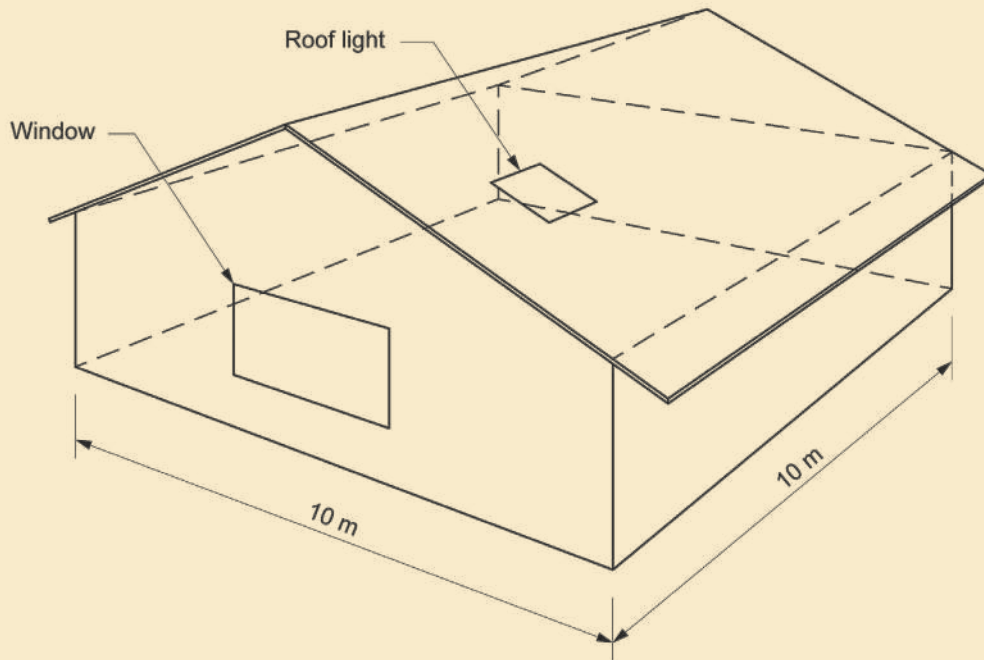
Method for determining proportional combination of *windows* and *roof lights*.

Description of above diagram

Area of the room which *requires* natural light is 100 m².

No natural light borrowed from adjoining rooms.

General requirements

Required window(s) to provide natural light must have a light transmitting area of at least 10% of the *floor area*.

10% of 100 m² = 10 m²

Or, *roof light(s)* to provide natural light must have a light transmitting area of at least 3% of the *floor area*.

3% of 100 m² = 3 m²

In the formula below, 3% of the *floor area* is expressed as the fraction 0.03 and 10% of the *floor area* is expressed as the fraction 0.1.

Calculations
Formula — for the area of *window(s)* required to compensate for *roof light(s)* short fall

Area of room covered by the *roof light(s)*

= (Area of *roof light(s)*) / 0.03

Required window(s) area

= [(*floor area*) – (Area covered by the *roof light(s)*)] / 10

Area of *window(s)* required to compensate for *roof light(s)* short fall

If the *roof light(s)* = 1 m²

Area of room covered by the *roof light(s)*

= (1 m² / 0.03)

= 33.33 m²

Required window(s) area

= (100 m² – 33.33 m²) / 10

= 6.67 m²

Formula — for the area of *roof light(s)* required to compensate for *window(s)* short fall

Health and Amenity

Area of room covered by the *window(s)*

$$= (\text{Area of } \textit{window(s)}) / 0.1$$

Required roof light(s) area

$$= [(\textit{floor area}) - (\text{Area covered by the } \textit{window(s)})] / 33.33$$

Area of *roof light(s)* required to compensate for *window(s)* short fall

If the *window(s)* = 5 m²

Area of room covered by the *window(s)*

$$= (5 \text{ m}^2 / 0.1)$$

$$= 50 \text{ m}^2$$

Required roof light(s) area

$$= (100 \text{ m}^2 - 50 \text{ m}^2) / 33.33 \text{ m}^2$$

$$= 1.5 \text{ m}^2$$

Notes:

1. For the purpose of this table a *window* excludes a *roof light*.
 2. The same proportional calculation principle applies if—
 - a. two or more *windows* are used; or
 - b. two or more *roof lights* are used.
- (b) A *window required* to provide natural light that faces a boundary of an adjoining allotment must not be less than a horizontal distance of 900 mm from that boundary.
- (c) Natural light to a room may come through one or more glazed panels or openings from an adjoining room (including an enclosed verandah) if—
- (i) the glazed panels or openings have an aggregate light transmitting area of not less than 10% of the *floor area* of the room to which it provides light; and
 - (ii) the adjoining room has—
 - (A) *windows*, excluding *roof lights* that—
 - (aa) have an aggregate light transmitting area of not less than 10% of the combined *floor area* of both rooms; and
 - (bb) are open to the sky or face a court or other space open to the sky or an open verandah, carport or the like; or
 - (B) *roof lights* that—
 - (aa) have an aggregate light transmitting area of not less than 3% of the combined *floor area* of both rooms; and
 - (bb) are open to the sky; or
 - (C) a proportional combination of *windows* and *roof lights required* by (A) and (B).
 - (iii) the areas specified in (i) and (ii) may be reduced as appropriate if direct natural light is provided from another source.
- (see [Figure 3.8.4.1](#))

Explanatory information:

1. Direct natural light provided from another source is intended to mean light from a *window* or *roof light* in the subject room. As the provision relates to natural light obtained from an adjoining room, “another source” refers to direct natural light provided to the subject room which does not meet the *required* allowance of either 10% or 3% of the *floor area* of that room. By not meeting the *required* amount of natural light, the “direct natural light from another source” can be used as a supplement to the natural light *required* from an adjoining room.
2. To borrow natural light from another room, 3.8.4.2(c)(i) allows light to pass through a glazed panel(s) or opening(s) from an adjoining room, which under 3.8.4.2(c)(ii), must have *windows*, *roof lights* or a combination of windows and *roof lights* of a minimum size in proportion to the combined floor areas of both rooms. The minimum size of

Health and Amenity

the glazed panel(s) or opening(s), and the minimum size of the *window* to the adjoining room are illustrated in Figure 3.8.4.1.

3. If a doorway is used as an opening to obtain natural light, it must do so when in the closed position (see Figure 3.8.4.1).

Figure 3.8.4.1 Method of determining areas of openings for borrowed light

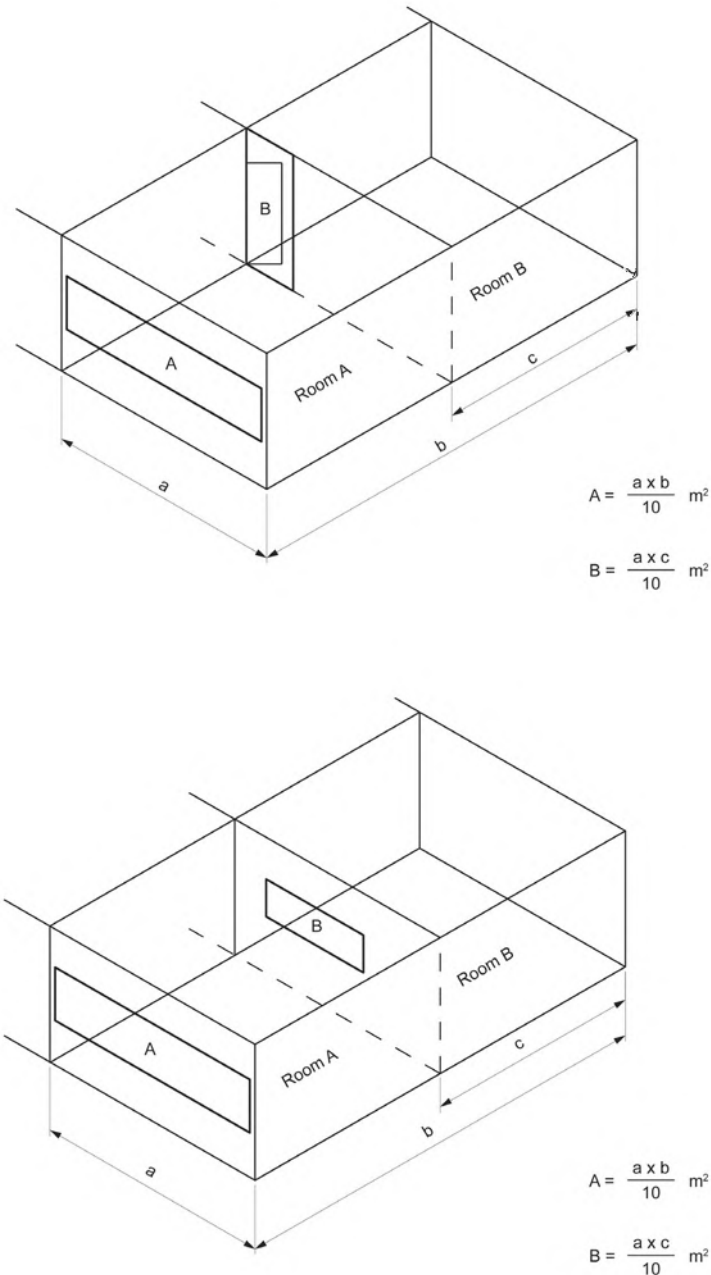

3.8.4.3 Artificial lighting

Sanitary compartments, bathrooms, shower rooms, airlocks and laundries must be provided with artificial lighting if natural light in accordance with the relevant provisions of 3.8.4.2 is not available—

- (a) at a rate of not less than one light fitting per 16 m² of *floor area*; or
- (b) in accordance with AS/NZS 1680.0.

Part 3.8.5 Ventilation

Appropriate *Performance Requirements*

Where an alternative ventilation system is proposed as a *Performance Solution* to that described in Part 3.8.5, that proposal must comply with—

- (a) *Performance Requirement P2.4.5*; and
- (b) *Performance Requirement P2.4.7*; and
- (c) the relevant *Performance Requirements* determined in accordance with A2.2(3) and A2.4(3) as applicable.

Explanatory information:

The requirements of this Part are to be read in conjunction with the condensation management requirements in Part 3.8.7 and the air movement requirements in Part 3.12.4. However, it should be noted that Part 3.12.4 does not apply in all States and Territories.

Acceptable Construction Manual

3.8.5.0 Application

Except for an exhaust fan from a *sanitary compartment*, laundry, kitchen or bathroom, *Performance Requirement P2.4.5* is satisfied for a mechanical ventilation system if it is installed in accordance with AS 1668.2.

Acceptable Construction Practice

3.8.5.1 Application

Compliance with this acceptable construction practice satisfies *Performance Requirement P2.4.5* for ventilation.

3.8.5.2 Ventilation requirements

Ventilation must be provided to a *habitable room*, *sanitary compartment*, bathroom, shower room, laundry and any other room occupied by a person for any purpose by any of the following means:

- (a) Openings, *windows*, doors or other devices which can be opened—
 - (i) with a ventilating area not less than 5% of the *floor area* of the room *required* to be ventilated; and
 - (ii) open to—
 - (A) a suitably sized court, or space open to the sky; or
 - (B) an open verandah, carport, or the like; or
 - (C) an adjoining room in accordance with (b).

Explanatory information:

The ventilating area of a *window* is measured as the size of the openable sash of the *window*. This is the case regardless of the type of *window*, i.e. whether it is an awning, casement or sliding *window* and irrespective of the restrictions on the openable sash.

- (b) Natural ventilation to a room may come through a *window*, opening, door or other device from an adjoining room (including an enclosed verandah) if—
 - (i) the room to be ventilated or the adjoining room is not a *sanitary compartment*; and
 - (ii) the *window*, opening, door or other device has a ventilating area of not less than 5% of the *floor area* of the room to be ventilated; and
 - (iii) the adjoining room has a *window*, opening, door or other device with a ventilating area of not less than 5% of the combined *floor areas* of both rooms; and
 - (iv) the ventilating areas specified may be reduced as appropriate if direct natural ventilation is provided from another source.

(See [Figure 3.8.5.1](#))

Explanatory information:

[3.8.5.2\(b\)](#) permits a room's *required* ventilation to be "borrowed" from an adjoining room, i.e. an adjoining room's ventilation can be used to help make up the total amount of ventilation *required*.

The use of borrowed ventilation is acceptable if the provisions of [3.8.5.2\(b\)](#) are applied to the subject room and to the total area of each relevant room.

Figure 3.8.5.1 Method of determining areas of openings for borrowed ventilation

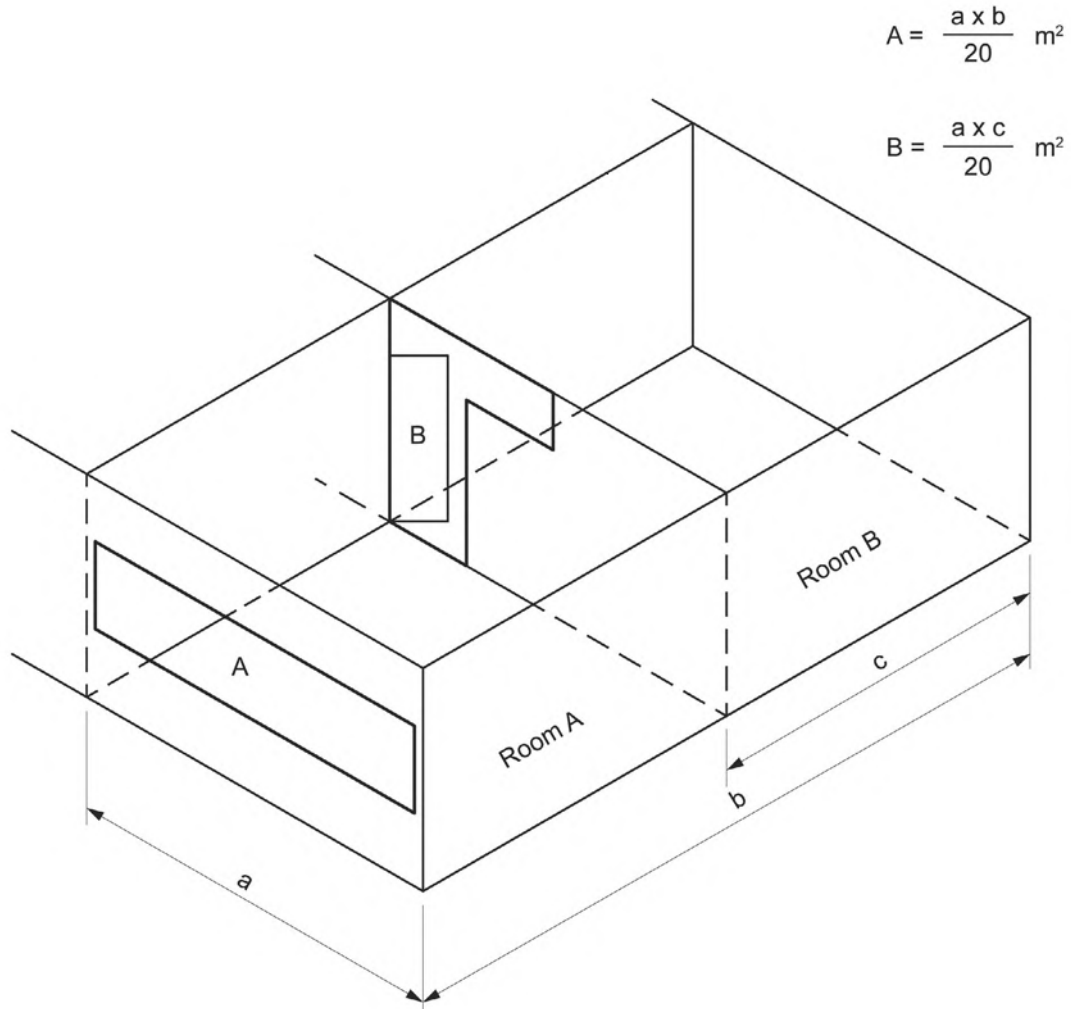

- (c) An exhaust fan or other means of mechanical ventilation may be used to ventilate a *sanitary compartment*, laundry, kitchen or bathroom, or where mechanical ventilation is provided in accordance with [3.8.5.3\(b\)](#), provided contaminated air exhausts comply with [3.8.7.3](#).

3.8.5.3 Location of sanitary compartments

Sanitary compartments must not open directly into a kitchen or pantry unless—

- access is by an airlock, hallway or other room, (see [Figure 3.8.5.2](#)); or
- the *sanitary compartment* is provided with an exhaust fan or other means of mechanical exhaust ventilation.

Health and Amenity

Figure 3.8.5.2 Acceptable location of non mechanically ventilated sanitary compartment

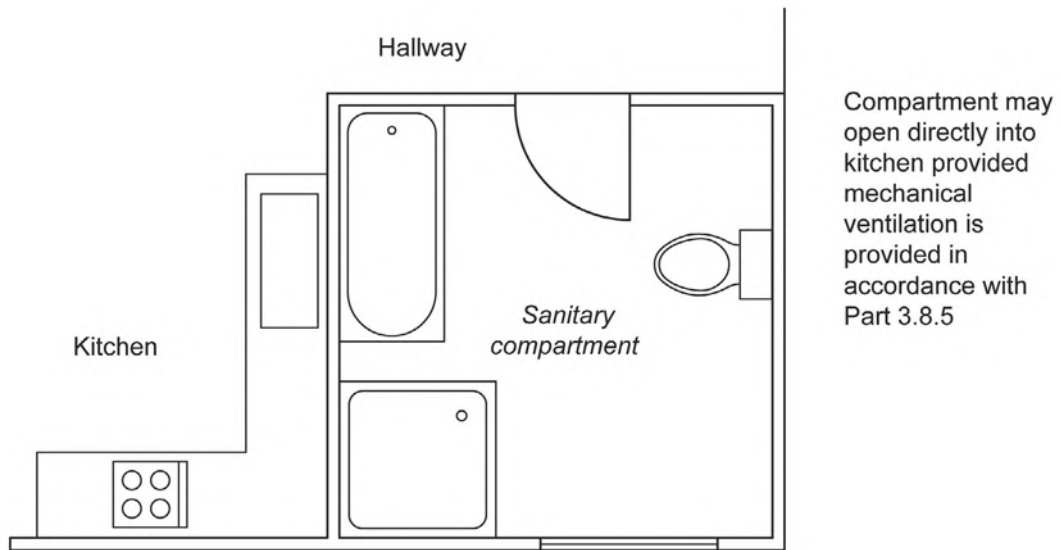

Part 3.8.6 Sound insulation

Appropriate *Performance Requirements*

Where an alternative sound insulation system is proposed as a *Performance Solution* to that described in [Part 3.8.6](#), that proposal must comply with—

- (a) *Performance Requirement P2.4.6*; and
- (b) the relevant *Performance Requirements* determined in accordance with [A2.2\(3\)](#) and [A2.4\(3\)](#) as applicable.

Acceptable Construction Practice

3.8.6.1 Application

Compliance with this acceptable construction practice satisfies *Performance Requirement P2.4.6* for sound insulation.

3.8.6.2 Sound insulation requirements

- (a) A *separating wall* between Class 1 buildings, or a wall that separates a Class 1 building from a Class 10a building which is not associated with the Class 1 building must—
 - (i) have an $R_w + C_{tr}$ (airborne) not less than 50; and
 - (ii) be of *discontinuous construction* if it separates a bathroom, *sanitary compartment*, laundry or kitchen in one Class 1 building from a *habitable room* (other than a kitchen) in an adjoining Class 1 building (see [Figure 3.8.6.1](#)).
- (b) For the purposes of (a)(ii), *discontinuous construction* means a wall system that has two separate leaves and that is not a staggered stud wall, that complies with the following:
 - (i) The wall has a minimum 20 mm cavity between leaves.
 - (ii) For masonry walls, where wall ties are *required* to connect leaves, the ties are of the resilient type.
 - (iii) For walls other than masonry, there is no mechanical linkage between leaves except at the periphery.
- (c) A wall *required* to have sound insulation must continue to—
 - (i) the underside of the roof above; or
 - (ii) a ceiling that provides the sound insulation *required* for the wall.

Explanatory information:

Insulation to reduce both airborne and impact noise transmission is *required* for parts of a wall that are common to adjoining Class 1 buildings but not parts of a wall located in the subfloor.

3.8.6.3 Determination of airborne sound insulation ratings

- (a) The $R_w + C_{tr}$ sound insulation rating *required* by [3.8.6.2\(a\)\(i\)](#) must—
 - (i) be determined in accordance with AS/NZS ISO 717.1, using results from laboratory measurements; or
 - (ii) comply with [Table 3.8.6.1a](#) to [Table 3.8.6.1d](#) and the relevant provisions of [3.8.6.4](#).

Explanatory information:

R_w is a measure of airborne sound insulation. C_{tr} is a spectrum adjustment factor that adjusts for low frequency sound levels. C_{tr} has been chosen in recognition of the problems caused by the high bass frequency outputs of modern home theatre systems and music reproduction equipment used by occupants of Class 1 buildings.

The wall configurations shown in [Table 3.8.6.1a](#) to [Table 3.8.6.1d](#) are typical examples. Other proprietary methods are available via testing to AS/NZS ISO 717.1 for meeting the $R_w + C_{tr}$ requirements of [3.8.6.2](#).

Figure 3.8.6.1 Required airborne and impact sound insulation — Plan view

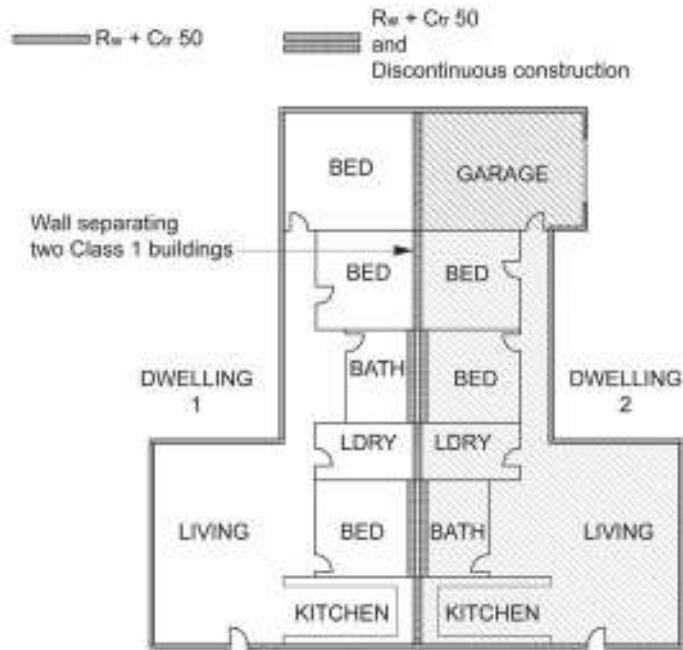

3.8.6.4 Construction of sound insulated walls

To achieve the appropriate level of sound insulation, walls must be constructed as follows:

- Stud wall junction — junctions of sound insulated walls with any perimeter walls and roof cladding must be sealed in accordance with [Figure 3.8.6.2](#).

Figure 3.8.6.2 Sound insulation between buildings - Stud wall junctions

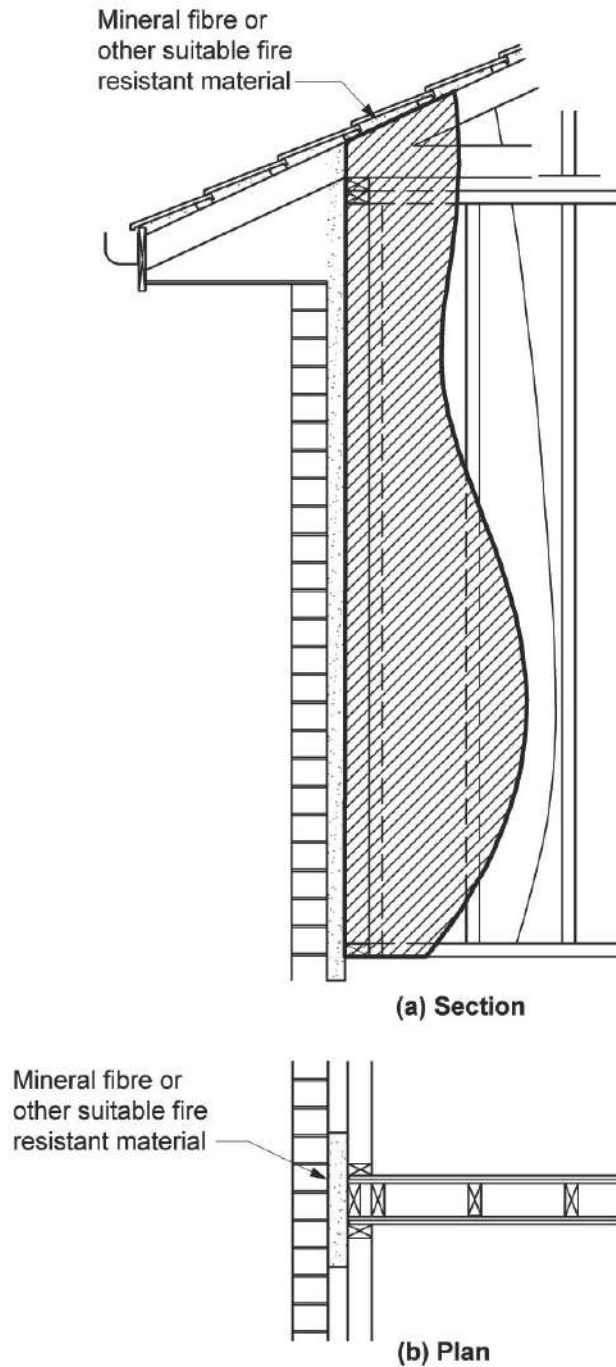

- (b) Masonry — units must be laid with all joints filled solid, except for articulation joints complying with [3.3.5.13](#), including those between the masonry and any adjoining construction.
- (c) Concrete panels — must have joints between panels and any adjoining construction filled solid.
- (d) Plasterboard sheeting — as follows:
 - (i) If two layers are *required*, the second layer joints must not coincide with those of the first layer (see [Figure 3.8.6.3](#)).
 - (ii) Joints between sheets including the outer layer or between sheets and any adjoining construction must be taped and filled solid.

Figure 3.8.6.3 Typical installation of plaster sheets for sound insulation

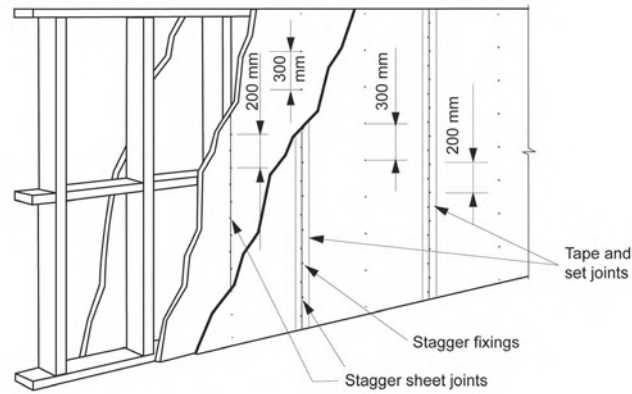

(a) Second layer positioned vertically

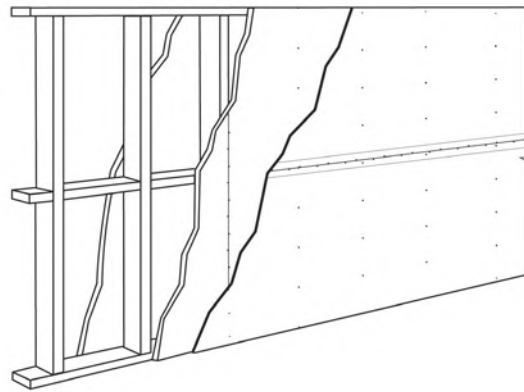

(b) Second layer positioned horizontally

- (e) Steel framed construction — steel framing and perimeter members must be installed as follows:
- (i) Steel framing members must be not less than 0.6 mm thick.
 - (ii) Studs must be not less than 63 mm in depth unless another depth is specified in [Table 3.8.6.1a](#) to [Table 3.8.6.1d](#).
 - (iii) All steel members at the perimeter of the wall must be securely fixed to the adjoining structure and the joints must be caulked so that there are no voids between the steel members and the wall.
- (f) Timber-framed construction — timber studs and perimeter members must be installed as follows:
- (i) Noggings and like members must not bridge between studs supporting different wall leaves.
 - (ii) All timber members at the perimeter of the wall must be securely fixed to the adjoining structure and the joints must be caulked so there are no voids between the timber members and the wall.

3.8.6.5 Services

- (a) Services must not be chased into concrete or masonry *separating walls*.
- (b) If a duct, soil, waste, water supply or storm water pipe is located in a *separating wall*—
- (i) a door or panel providing access to a duct or pipe *required* to be separated must—
 - (A) not open into any *habitable room*, other than a kitchen; and
 - (B) in any other part must be firmly fixed so as to overlap the frame or rebate of the frame by not less than 10 mm and be constructed of—
 - (aa) wood, plasterboard or blockboard not less than 33 mm thick; or

Health and Amenity

- (bb) compressed fibre reinforced cement sheeting not less than 9 mm thick; or
- (cc) other suitable material with a mass per unit area not less than 24.4 kg/m²; and
- (ii) in the case of a water supply pipe, it must—
 - (A) only be installed in *discontinuous construction*; and
 - (B) in the case of a water supply pipe that serves one dwelling, not be fixed to the wall leaf on the side of any other dwelling and have a clearance not less than 10 mm to the other wall leaf.
- (c) Electrical outlets must be offset from each other—
 - (i) in masonry walling, not less than 100 mm; and
 - (ii) in timber or steel-framed walling, not less than 300 mm.

Table 3.8.6.1a Acceptable forms of construction for masonry walls

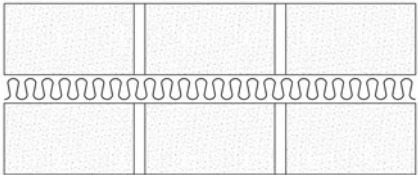
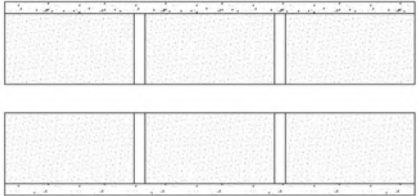
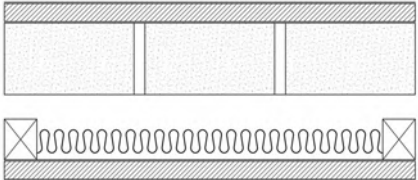
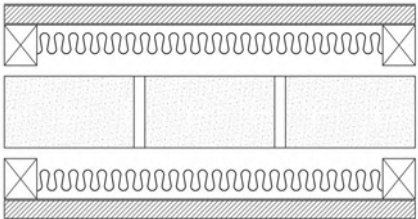
Description	$R_w + C_{tr}$ (not less than)	Construction
Two leaves of 110 mm clay brick masonry with— <ul style="list-style-type: none"> (a) <i>cavity</i> not less than 50 mm between leaves; and (b) 50 mm thick glass wool insulation with a density of 11 kg/m³ or 50 mm thick polyester insulation with a density of 20 kg/m³ in the <i>cavity</i>. 	50	
Two leaves of 110 mm clay brick masonry with— <ul style="list-style-type: none"> (a) <i>cavity</i> not less than 50 mm between leaves; and (b) 13 mm cement render on each outside face. 	50	
Single leaf of 110 mm clay brick masonry with— <ul style="list-style-type: none"> (a) a row of 70 mm x 35 mm timber studs or 64 mm steel studs at 600 mm centres, spaced 20 mm from the masonry wall; and (b) 50 mm thick mineral insulation or glass wool insulation with a density of 11 kg/m³ positioned between studs; and (c) one layer of 13 mm plasterboard fixed to outside face of studs and outside face of masonry. 	50	
Single leaf of 90 mm clay brick masonry with— <ul style="list-style-type: none"> (a) a row of 70 mm x 35 mm timber studs or 64 mm steel studs at 600 mm centres, spaced 20 mm from each face of the masonry wall; and (b) 50 mm thick mineral insulation or glass wool insulation with a density of 11 kg/m³ positioned between studs in each row; and 	50	

Health and Amenity

Description	$R_w + C_{tr}$ (not less than)	Construction
(c) one layer of 13 mm plasterboard fixed to studs on each outside face.		
Single leaf of 220 mm brick masonry with 13 mm cement render on each face.	50	

Table 3.8.6.1b Acceptable forms of construction for concrete walls

Description	$R_w + C_{tr}$ (not less than)	Construction
150 mm thick plain off form concrete.	50	
200 mm thick concrete panel with one layer of 13 mm plasterboard or 13 mm cement render on each face.	50	
100 mm thick concrete panel with— (a) a row of 64 mm steel studs at 600 mm centres, spaced 25 mm from the concrete panel; and (b) 80 mm thick polyester insulation or 50 mm thick glass wool insulation with a density of 11 kg/m ³ , positioned between studs; and (c) two layers of 13 mm plasterboard fixed to outside face of studs and one layer of 13 mm plasterboard fixed to outside face of concrete panel.	50	
125 mm thick concrete panel with— (a) a row of 64 mm steel studs at 600 mm centres, spaced 20 mm from the concrete panel; and (b) 70 mm polyester insulation with a density of 9 kg/m ³ , positioned between studs; and (c) one layer of 13 mm plasterboard fixed to the outside face of the studs.	50	

Table 3.8.6.1c Acceptable forms of construction for autoclaved aerated concrete walls

Description	$R_w + C_{tr}$ (not less than)	Construction
75 mm thick autoclaved aerated concrete wall panel with— (a) a row of 64 mm steel studs at 600 mm centres, spaced 20 mm from the autoclaved aerated concrete wall panel; and (b) 75 mm thick glass wool	50	

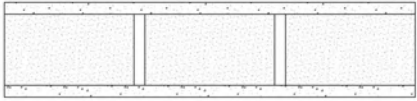
Health and Amenity

Description	$R_w + C_{tr}$ (not less than)	Construction
insulation with a density of 11 kg/m ³ positioned between studs; and (c) one layer of 10 mm moisture resistant plasterboard or 13 mm fire protective grade plasterboard fixed to outside face of studs and outside face of autoclaved aerated concrete wall panel.		
75 mm thick autoclaved aerated concrete wall panel with— (a) a row of 64 mm steel studs at 600 mm centres, spaced 35 mm from the autoclaved aerated concrete panel wall; and (b) 28 mm metal furring channels fixed to the outside face of the autoclaved aerated concrete wall panel, with 50 mm thick polyester insulation with a density of 9 kg/m ³ positioned between furring channels and one layer of 13 mm fire protective grade plasterboard fixed to furring channels; and (c) 105 mm thick glass wool insulation with a density of 7 kg/m ³ positioned between studs; and (d) one layer of 13 mm fire protective grade plasterboard fixed to the outside face of the studs.	50	
Two leaves of 75 mm autoclaved aerated concrete wall panel with— (a) a cavity not less than 30 mm between panels containing 50 mm glass wool insulation with a density of 11 kg/m ³ ; and (b) one layer of 10 mm plasterboard fixed to outside face of each panel.	50	

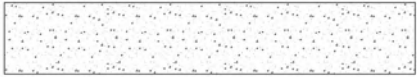
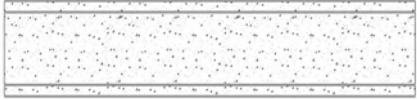
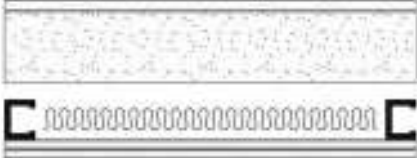
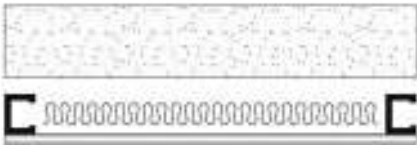
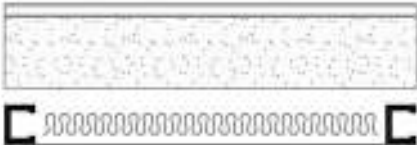
Table 3.8.6.1d Acceptable forms of construction for timber and steel framed walls

Description	$R_w + C_{tr}$ (not less than)	Construction
Two rows of 90 x 35 mm timber studs or two rows of 64 mm steel studs at 600 mm centres with— (a) an air gap not less than 20 mm between the rows of studs; and (b) 50 mm thick glass wool insulation or 60 mm thick polyester insulation with a density of 11 kg/m ³ ; positioned	50	

Health and Amenity

Description	$R_w + C_{tr}$ (not less than)	Construction
(c) between one row of studs, and two layers of 13 mm fire protective grade plasterboard or one layer of 6 mm fibre cement sheet and one layer of 13 mm fire protective grade plasterboard, fixed to outside face of studs.		
Two rows of 64 mm steel studs at 600 mm centres with—	50	
(a) an air gap not less than 80 mm between the rows of studs; and		
(b) 200 mm thick polyester insulation with a density of 14 kg/m ³ ; positioned between studs; and		
(c) one layer of 13 mm fire-protective grade plasterboard and one layer 13 mm plasterboard on one outside face and one layer of 13 mm fire-protective grade plasterboard on the other outside face.		

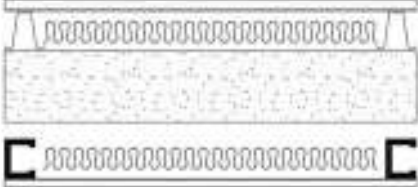
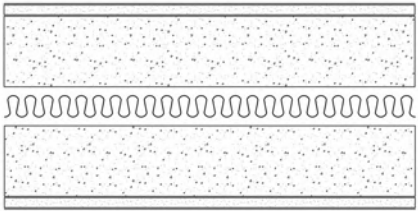
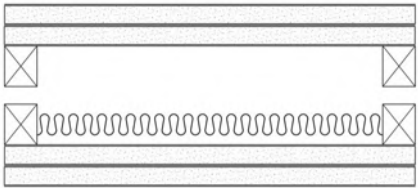
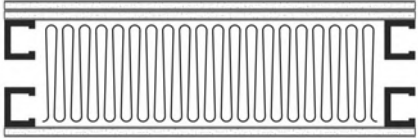
State and Territory Variations

In Northern Territory Part 3.8.6 acceptable construction practice is replaced with the following:

Acceptable construction practice

3.8.6.1 Application

Compliance with this Part satisfies [Performance Requirement P2.4.6](#) for sound insulation.

3.8.6.2 Sound insulation requirements

- (a) A [separating wall](#) between two or more Class 1 buildings must—
- achieve the weighted sound reduction index (R_w) and impact sound resistance [required](#) by [Table 3.8.6.1](#); and
 - be installed in accordance with the appropriate requirements of [3.8.6.3](#) and [3.8.6.4](#); and
- (b) for the purpose of this Part, the R_w may be determined in accordance with AS/NZS ISO 717.1.

Table 3.8.6.1 Required R_w and sound impact levels for separating walls

Separating wall — location and penetrations	Impact sound resistance (as per Table 3.8.6.2)	R_w (as per Table 3.8.6.3)
Type A Between a bathroom, sanitary compartment , laundry or kitchen and a habitable room (other than a kitchen) in an adjoining Class 1 building (dwelling) (see Figure 3.8.6.1).	Yes	50
Type B In all other cases to those listed as Type A. (See Figure 3.8.6.1)	No	45
Soil and waste pipes A waste pipe or other penetration that serves or passes through a	No	45

Health and Amenity

Separating wall — location and penetrations	Impact sound resistance (as per Table 3.8.6.2)	R _w (as per Table 3.8.6.3)
<p><i>separating wall</i> between houses—</p> <p>(a) If the adjacent room is a <i>habitable room</i> (other than a kitchen); or</p>		
<p>Soil and waste pipes</p> <p>A waste pipe or other penetration that serves or passes through a <i>separating wall</i> between houses—</p> <p>(b) If the room is a kitchen or any other room.</p>	No	30

Figure 3.8.6.1 Required R_w—Plan view

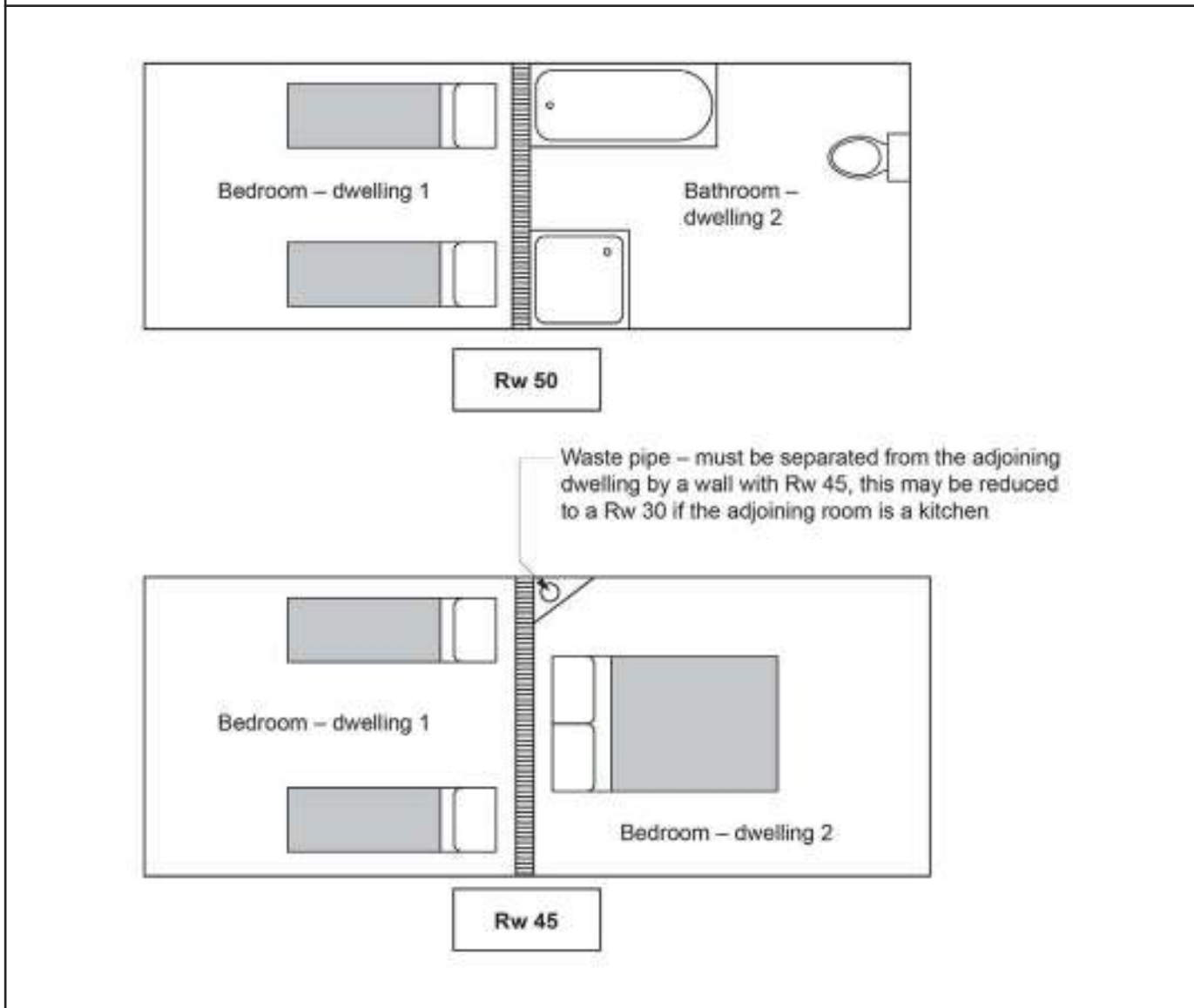

3.8.6.3 General installation requirements for walls

- (a) To achieve the appropriate R_w and impact sound resistance, walls must—
 - (i) be installed in accordance with the appropriate requirements contained in (b) to (f); and
 - (ii) at the junction of sound insulated walls with perimeter walls and roof cladding, be sealed in accordance with any relevant detail in Figure 3.8.6.3.
- (b) Masonry units must—
 - (i) be laid with all joints filled solid, including those between the masonry and any adjoining construction; and

Health and Amenity

- (ii) not be chased for services.
- (c) Joints between concrete slabs, wall units and any adjoining construction must be filled solid.
- (d) Plasterboard must be installed as follows:
 - (i) If one layer is *required* under this Part, joints must be staggered with the joints in sheets on the opposite face of the wall.
 - (ii) If 2 layers are *required*, the first layer must be fixed according to (i) and the second layer must be fixed to the first layer with nails, screws or adhesive so that the joints do not coincide with those of the first layer.
 - (iii) Joints between sheets or between sheets and any adjoining construction must be taped and filled solid.
 - (iv) Fire-protective grade plasterboard (when nominated) must be the grade manufactured for use in fire-resisting construction.

Figure 3.8.6.2 Typical installation of plaster sheets for sound insulation

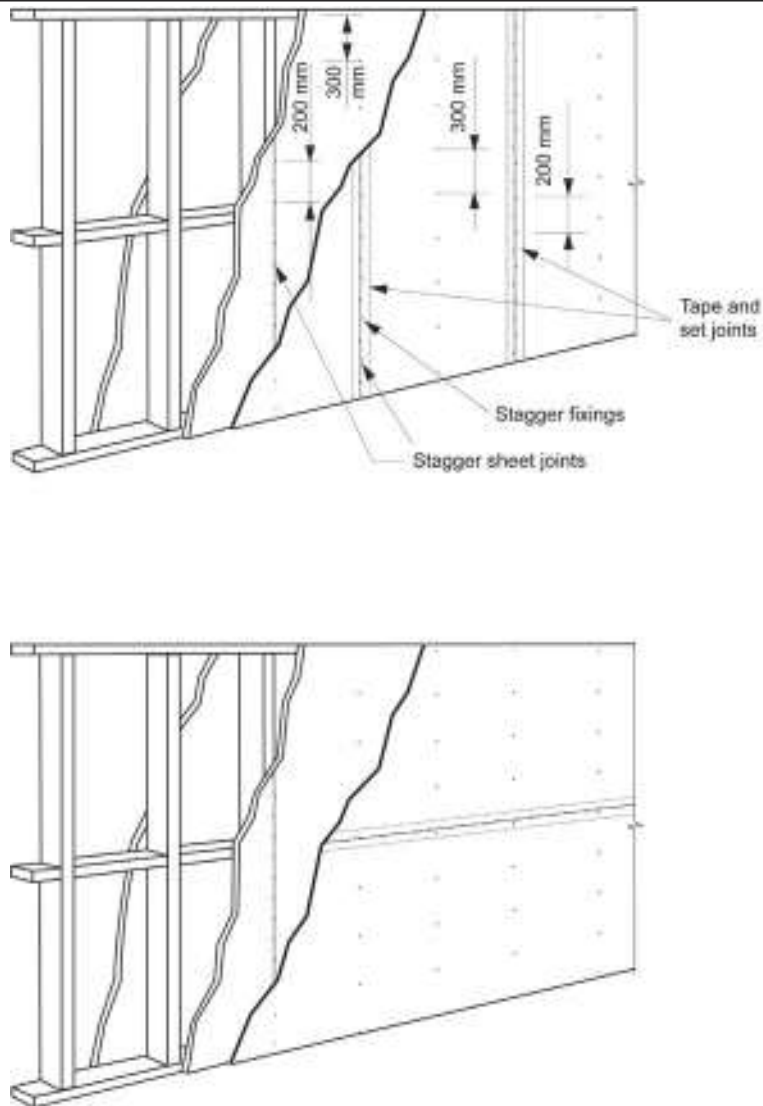

- (e) Steel studs and perimeter members must be installed as follows:
 - (i) The section of steel must be not less than 0.6 mm thick.
 - (ii) Studs must be not less than 63 mm in depth unless another depth is specified in the Table.
 - (iii) Studs must be fixed to steel top and bottom plates of sufficient depth to permit secure fixing of the plasterboard.
 - (iv) All steel members at the perimeter of the wall must be securely fixed to the adjoining structure and bedded in resilient compound or the joints must be caulked so that there are no voids between the steel members and the wall.
- (f) Timber studs and perimeter members must be installed as follows:
 - (i) Studs must be fixed to top and bottom plates of sufficient depth to permit secure fixing of the plasterboard.

- (ii) Noggings and like members must not bridge between studs supporting different wall leaves.
- (iii) All timber members at the perimeter of the wall must be securely fixed to the adjoining structure and bedded in resilient compound or the joints must be caulked so there are no voids between the timber members and the wall.

3.8.6.4 Soil and waste pipes

If a soil or waste pipe passes through a *separating wall*—

- (a) a door or panel providing access to the pipe must not open into any *habitable room*, other than a kitchen; and
- (b) an access door or panel in any other part must be firmly fixed so as to overlap the frame or rebate of the frame by not less than 10 mm, be fitted with a sealing gasket along all edges and constructed of—
 - (i) wood, plasterboard or blockboard not less than 38 mm thick; or
 - (ii) compressed fibre reinforced cement sheeting not less than 9 mm thick; or
 - (iii) other suitable material with a mass per unit area not less than 24.4 kg/m².

Explanatory information:

The wall configurations shown in [Tables 3.8.6.2](#) and [3.8.6.3](#) are typical examples. Other proprietary methods are available for meeting the R_w and sound impact levels *required* by [Table 3.8.6.1](#).

Table 3.8.6.2 Construction of walls to reduce impact sound and achieve a 50 R_w

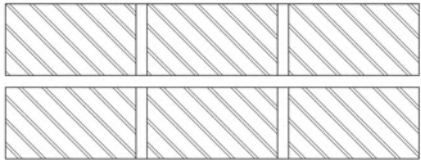
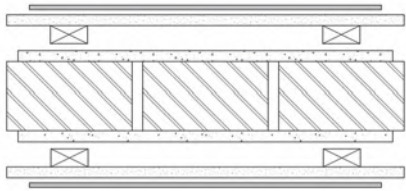
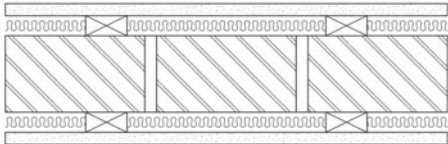
Wall construction type	Design diagram — Plan view
<p>Cavity brickwork</p> <p>2 leaves 90 mm brick masonry with—</p> <ul style="list-style-type: none"> (a) all joints filled solid with mortar; and (b) an air space not less than 40 mm between the leaves; and (c) the leaves connected only by ties in accordance with AS 3700, except ‘(for piers—isolated or engaged)’ is removed from Clause 8.5.1(d) and where Clause 8.5.1 requires design as for unreinforced masonry in accordance with Section 7, the member must also be designed as unreinforced masonry in accordance with Tables 10.3 and 4.1(a)(i)(C) of AS 3700; and (d) wall tie spacing in accordance with details set out in Part 3.3. 	
<p>Single leaf brickwork</p> <p>80 mm thick brick masonry with—</p> <ul style="list-style-type: none"> (a) each face rendered 13 mm thick; and (b) 50x12 mm thick timber battens at not more than 610 mm centres fixed to each face but not recessed into the render; and (c) one layer of 12 mm thick softboard nailed to the battens; and (d) 6 mm thick medium density hardboard adhesive-fixed to the softboard. 	
<p>Concrete blockwork</p> <p>190 mm thick concrete block masonry with—</p> <ul style="list-style-type: none"> (a) each face of the blocks fitted with 50x50 mm timber battens, spaced at not more than 610 mm centres, screw-fixed into resilient plugs with rubber inserts; and (b) the space between the battens completely filled with mineral or glass wool blanket or batts not less than 50 mm thick; and 	

Health and Amenity







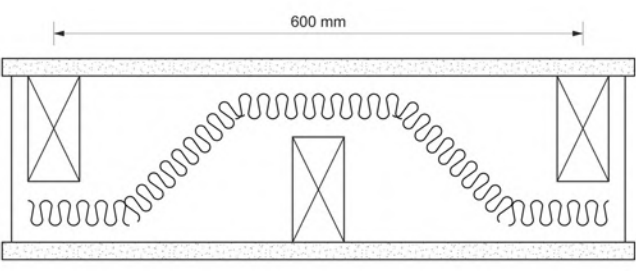
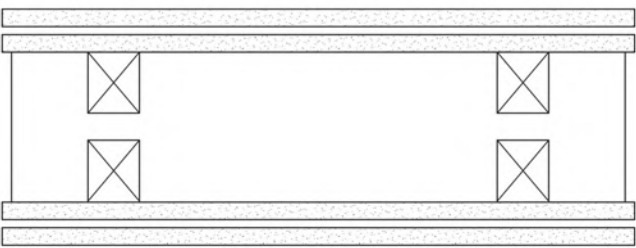
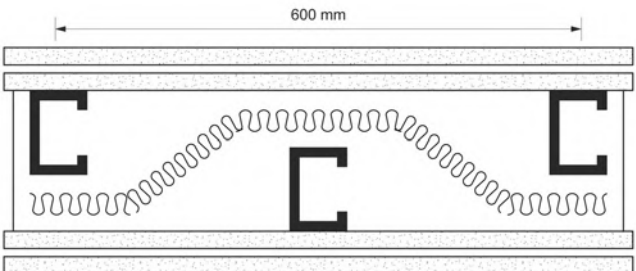
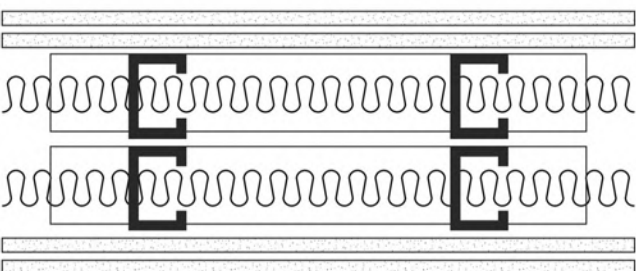

Wall construction type	Design diagram — Plan view
<p>(c) the outer face of the battens finished with plasterboard not less than 10 mm thick.</p> <p>Timber-framed walling</p> <p>70 x 45 mm F5 staggered timber studs at 600 mm centres both sides on 120x35 mm F5 timber plates with—</p> <p>(a) one layer of 16 mm fire protective grade plasterboard on both faces; and</p> <p>(b) 50 mm glass fibre batts.</p>	
<p>Timber-framed walling</p> <p>70 x 45 mm F5 timber double studs at 450 – 600 mm centres with an air space not less than 20 mm between studs with two layers of 13 mm fire protective grade plasterboard on both faces.</p>	
<p>Steel stud walling</p> <p>64 mm staggered metal studs (0.75 mm base metal thickness) at 600 mm centres both sides, clipped in 92 mm metal tracks with—</p> <p>(a) two layers of 13 mm fire protective grade plasterboard to each side; and</p> <p>(b) 50 mm glasswool cavity batts.</p>	
<p>Steel stud walling</p> <p>64 mm double metal studs (0.75 mm base metal thickness) at 600 mm centres with an air space not less than 20 mm between studs, in separate frames with no mechanical links with—</p> <p>(a) two layers of 13 mm fire protective grade plasterboard to each side; and</p> <p>(b) 50 mm glasswool cavity batts.</p>	

Table 3.8.6.3 R_w applicable to construction

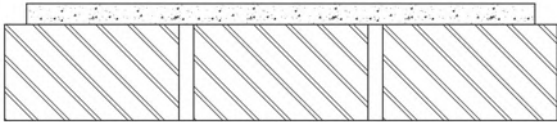
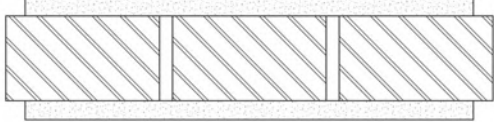
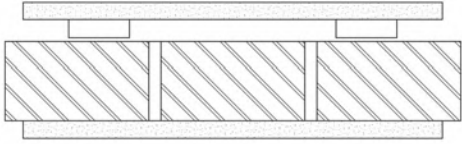
Wall construction type	R _w	Design diagram — Plan view
<p>Clay brickwork</p> <p>110 mm thick in one or more leaves and with a mass per unit area of not less than 290 kg/m².</p>	45	
<p>Clay brickwork</p> <p>80 mm thick, pressed brick and rendered 13 mm on one side, the mass per unit area of the</p>	45	

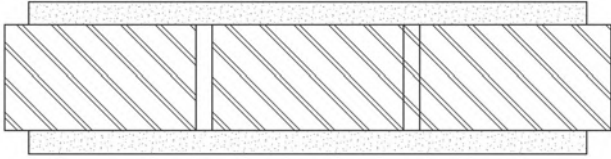
Health and Amenity

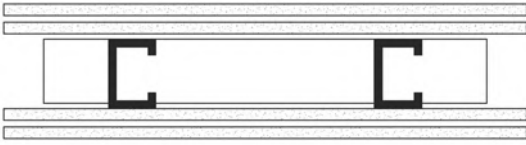
Wall construction type	R _w	Design diagram — Plan view
unrendered wall being not less than 215 kg/m ² .		
Calcium silicate brickwork 90 mm thick calcium silicate brick with one layer of 10 mm fire protective grade plasterboard on each side.	45	
Calcium silicate brickwork 90 mm thick calcium silicate brick with one layer of 10 mm fire protective plasterboard and one layer of fire protective plasterboard on metal furring channels.	45	
Concrete blockwork 190 mm solid units (or thicker) Material density 2200 kg/m ³	45	
Concrete blockwork 110 mm solid units (or thicker) Material density 2200 kg/m ³ Material thickness — 83 mm min. 10 mm plasterboard or 12 mm render on each face.	45	
Concrete wall In-situ concrete — 125 mm thick and with a density of not less than 2200 kg/m ³ .	45	
Steel stud walling With 2 layers of 16 mm thick fire-protective grade plasterboard fixed to each face.	45	
Steel stud walling With 2 layers of 13 mm plasterboard on both sides of 75 mm studs.	45	
Timber stud walling 70 x 45 mm timber studs at 450 – 600 mm centres with (a) one layer of 16 mm fire protective grade plasterboard on one face; and (b) 50 mm glass fibre batts; and (c) one layer of 16 mm fire protective grade plasterboard on metal resilient channel.	49	

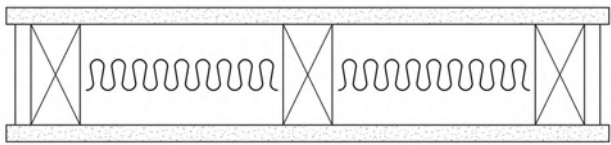
Health and Amenity





Wall construction type	R _w	Design diagram — Plan view
<p>Timber stud walling</p> <p>70 x 45 mm timber studs at 450 – 600 mm centres with two layers of 16 mm fire protective grade plasterboard on both sides.</p>	46	
<p>Ducts or other construction separating soil and waste pipes from units — masonry</p> <p>Not less than 90 mm thick.</p>	30	
<p>Ducts or other construction separating soil and waste pipes from units — plasterboard</p> <p>2 layers of plasterboard each 10 mm thick, fixed to timber studs not less than 75x50 mm and spaced at not more than 400 mm centres.</p>	30	
<p>Ducts or other construction separating soil and waste pipes from units — plasterboard</p> <p>2 layers of plasterboard each 13 mm thick, one on each side of steel studs not less than 50 mm deep and spaced at not more than 400 mm centres.</p>	30	

Figure 3.8.6.3 Sound insulation between units — Double stud wall configuration

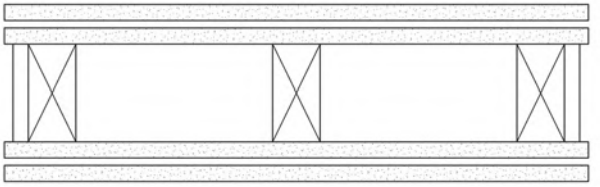

Part 3.8.7 Condensation management

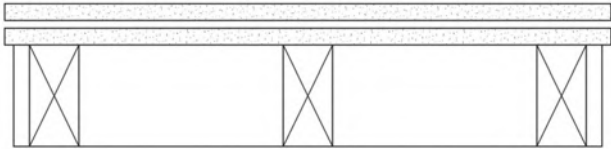
Appropriate Performance Requirements

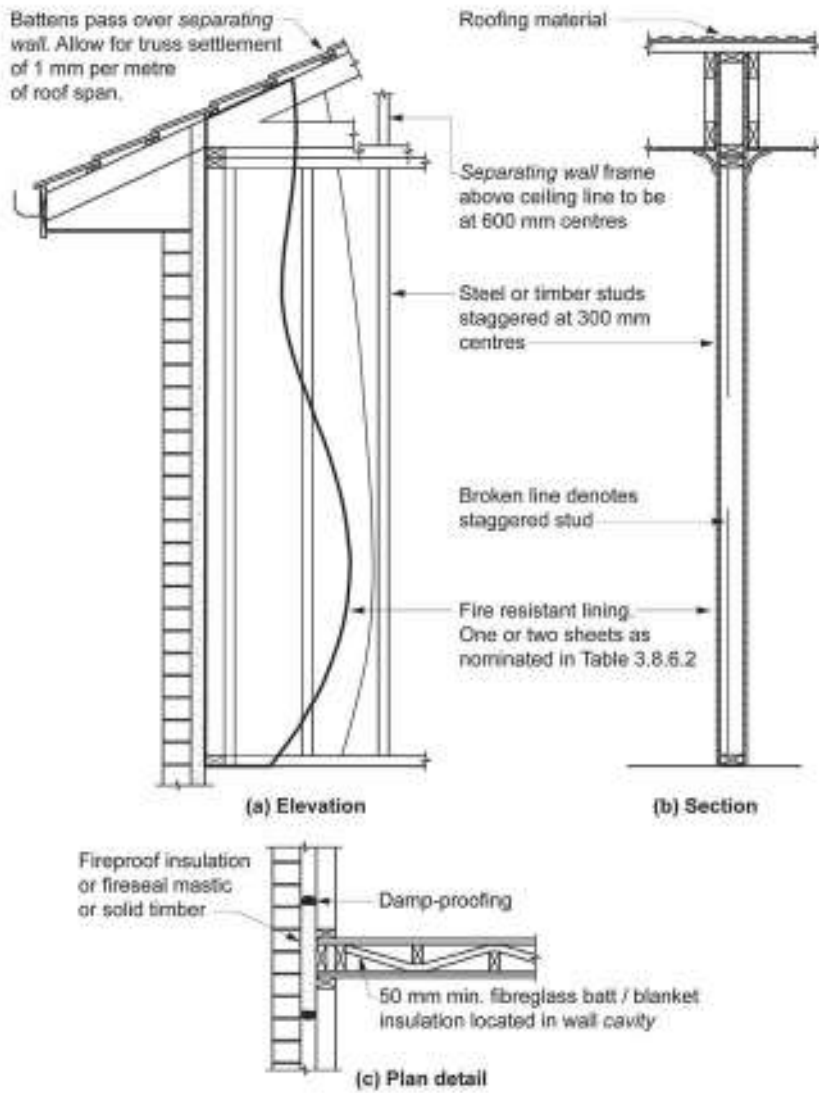
Where an alternative *condensation* management system is proposed as a *Performance Solution* to that described in [Part 3.8.7](#), that proposal must comply with—

- (a) [Performance Requirement P2.4.7](#); and
- (b) the relevant [Performance Requirements](#) determined in accordance with [A2.2\(3\)](#) and [A2.4\(3\)](#) as applicable.

State and Territory Variations

In Tasmania insert the following Note: Refer to the guidance in the “Guide for Control of Condensation and Mould in Tasmanian Homes” that should be adhered to where possible.

In the Australian Capital Territory:

See the [ACT Appendix](#) for further information on condensation management in the ACT.

Acceptable Construction Practice

3.8.7.1 Application

Compliance with this Acceptable Construction Practice satisfies [Performance Requirement P2.4.7](#).

Explanatory information:

The intent of these requirements is to assist in the mitigation of *condensation* within a building. The installation of a *condensation* management system may not prevent *condensation* from occurring.

3.8.7.2 Pliable building membrane

- (a) Where a *pliable building membrane* is installed in an *external wall*, it must—
 - (i) comply with AS/NZS 4200.1; and
 - (ii) be installed in accordance with AS 4200.2; and
 - (iii) be a vapour permeable membrane for *climate zones* 6, 7 and 8; and
 - (iv) be located on the exterior side of the primary insulation layer of wall assemblies that form the external envelope of a building.
- (b) Except for single skin masonry or single skin concrete, where a *pliable building membrane* is not installed in an *external wall*, the primary *water control layer* must be separated from *water sensitive materials* by a drained cavity.

3.8.7.3 Flow rate and discharge of exhaust systems

- (a) An exhaust system installed in a kitchen, bathroom, *sanitary compartment* or laundry must have a minimum flow rate of—
 - (i) 25 L/s for a bathroom or *sanitary compartment*; and
 - (ii) 40 L/s for a kitchen or laundry.
- (b) Exhaust from a bathroom, *sanitary compartment*, or laundry must be discharged—
 - (i) directly or via a shaft or duct to *outdoor air*; or
 - (ii) to a roof space that is ventilated in accordance with [3.8.7.4](#).

3.8.7.4 Ventilation of roof spaces

- (a) Where an exhaust system covered by [3.8.7.3](#) discharges into a roof space, the roof space must be ventilated to *outdoor air* through evenly distributed openings.
- (b) Openings *required* by (a) must have a total unobstructed area of 1/300 of the respective ceiling area if the roof pitch is more than 22°, or 1/150 of the respective ceiling area if the roof pitch is not more than 22°.

Health and Amenity

- (c) 30% of the total unobstructed area *required* by (b) must be located not more than 900 mm below the ridge or highest point of the roof space, measured vertically, with the remaining *required* area provided by eave vents.

Part **3.9**

Safe Movement and Access

Part 3.9.1 **Stairway and ramp construction**

Part 3.9.2 **Barriers and handrails**

Part 3.9.3 * * * * *

Part 3.9 Safe Movement and Access

Part 3.9.1 Stairway and ramp construction

3.9.1.0 Explanation of terms

Acceptable Construction Practice

3.9.1.1 Application

3.9.1.2 Stairway construction

3.9.1.3 Ramps

3.9.1.4 Slip-resistance

3.9.1.5 Landings

3.9.1.6 Thresholds

Part 3.9.2 Barriers and handrails

Acceptable Construction Practice

3.9.2.1 Application

3.9.2.2 Barriers to prevent falls

3.9.2.3 Construction of barriers to prevent falls

3.9.2.4 Handrails

3.9.2.5 Construction of wire barriers

3.9.2.6 Protection of openable windows — bedrooms

3.9.2.7 Protection of openable windows — rooms other than bedrooms

Part 3.9.3 * * * * *

Part 3.9.1 Stairway and ramp construction

Appropriate *Performance Requirements*

Where an alternative stairway or ramp system is proposed as a *Performance Solution* to that described in [Part 3.9.1](#), that proposal must comply with—

- (a) *Performance Requirement P2.5.1*; and
- (b) the relevant *Performance Requirements* determined in accordance with [A2.2\(3\)](#) and [A2.4\(3\)](#) as applicable.

3.9.1.0 Explanation of terms

The following figures depict stairway members and associated terminology used to describe them in the *Housing Provisions*. Some items such as barriers and handrails have been omitted for clarity.

Figure 3.9.1.0 Stairway terms

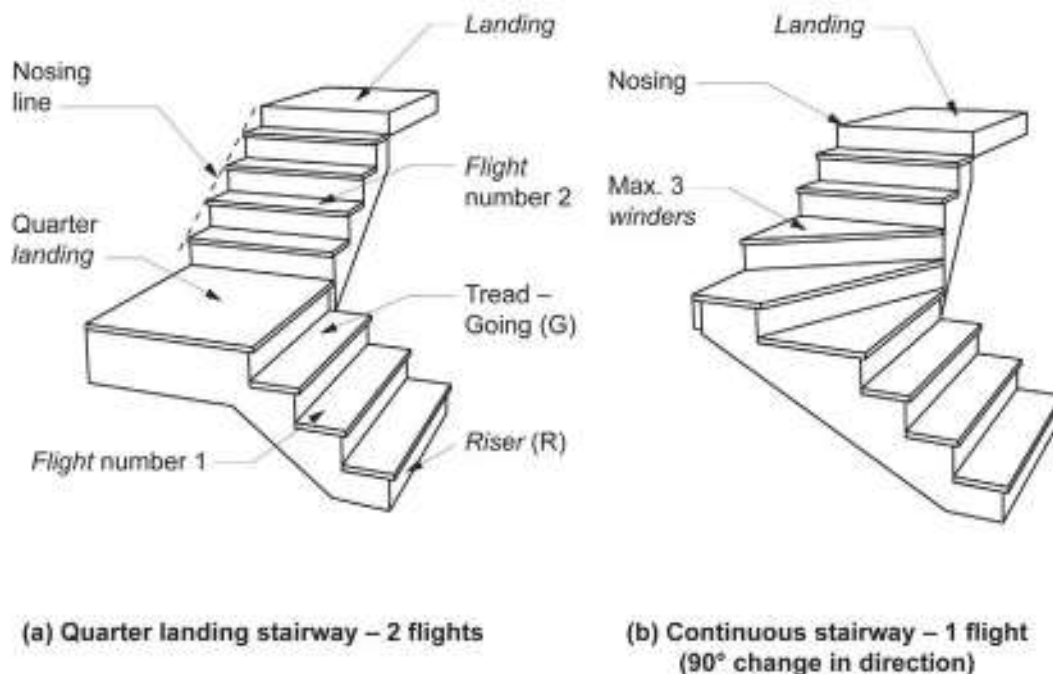

Explanatory information:

1. **Alpine areas:**
The requirements of this Part are to be read in conjunction with [Part 3.10.4](#) where a building is located in an *alpine area* and contains an external stairway or ramp.
2. **Room heights:**
[3.8.2.2](#) contains the *required* height for a ceiling above a stairway, ramp or *landing*, measured vertically above the nosing line of stairway treads or the floor surface of a ramp or *landing*.

Acceptable Construction Practice

3.9.1.1 Application

Compliance with this acceptable construction practice satisfies *Performance Requirement P2.5.1* for stairway and ramp construction.

Safe Movement and Access

3.9.1.2 Stairway construction

- (a) A stairway must be designed to take loading forces in accordance with AS/NZS 1170.1 and must have—
- (i) not more than 18 and not less than 2 *risers* in each *flight*; and
 - (ii) *Goings* (G), *risers* (R) and a slope relationship quantity ($2R + G$) in accordance with Table 3.9.1.1, except as permitted by (b) and (c); and

Table 3.9.1.1 Riser and going dimensions (mm)

Stair type	Riser (R) (see Figure 3.9.1.4 below)		Going (G) (see Figure 3.9.1.4 below)		Slope relationship (2R+G)	
	Max	Min	Max	Min	Max	Min
Stairs (other than spiral)	190	115	355	240	700	550
Spiral	220	140	370	210	680	590

Note to Table 3.9.1.1: *Riser* and *going* dimensions must be measured in accordance with Figure 3.9.1.4.

Figure 3.9.1.4 Riser and going dimensions—Measurement

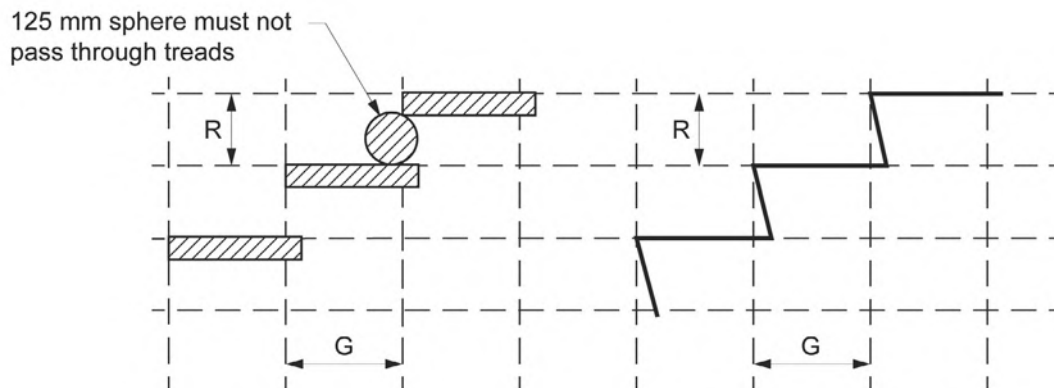

- (iii) constant *goings* and *risers* throughout each *flight*, except as permitted by (c) and (d), and the dimensions of *goings* (G) and *risers* (R) in accordance with (a), (b) and (c) are considered constant if the variation between—
 - (A) adjacent *risers*, or between adjacent *goings*, is no greater than 5 mm; and
 - (B) the largest and smallest *riser* within a *flight*, or the largest and smallest *going* within a *flight*, does not exceed 10 mm; and
 - (iv) *risers* which do not have any openings that would allow a 125 mm sphere to pass through between the treads; and
 - (v) treads of solid construction (not mesh or other perforated material) if the stairway is more than 10 m high or connects more than 3 storeys.
- (b) In the case of a stairway serving only non-*habitable rooms*, such as attics, storerooms and the like that are not used on a regular or daily basis—
- (i) the *going* (G), *riser* (R) and slope relationship quantity ($2R + G$) in accordance with Table 3.9.1.1 may be substituted with those in Table 3.9.1.2; and
 - (ii) need not comply with 3.9.1.2(a)(iv).

Table 3.9.1.2 Riser and going dimensions (mm)—stairways serving non-habitable rooms used infrequently

Riser (R)		Going (G)		Slope relationship (2R+G)	
Max	Min	Max	Min	Max	Min
225	130	355	215	700	540

Safe Movement and Access

Note to Table 3.9.1.2: The *going* (G) must be not more than the tread depth plus a maximum gap of 30 mm between the rear edge of one tread and the nosing of the tread above.

Explanatory information:

1. **Not more than 18 and not less than 2 risers:**

3.9.1.2(a)(i) states that a stairway must have not more than 18 and not less than 2 *risers* in each *flight*. Where there are less than 2 *risers* in a *flight*, it does not comprise a stairway for the purpose of the BCA. 18 *risers* is considered to be the maximum reasonable number that an average person can negotiate before requiring a rest. *Winders* are counted as part of the maximum number of 18 *risers*. More than 1 *riser* is considered necessary for a person to observe and adjust to a change in level.

2. **Going and riser dimensions:**

The purpose of 3.9.1.2 is to achieve constant *going* and *riser* dimensions deemed safe for people to walk up and down. This minimises the risk of people overstepping during descent on uneven stairs (due to short *goings*) and tripping on ascent (due to high *risers*). Table 3.9.1.1 and Table 3.9.1.2 express ratios between *going* and *riser* dimensions which are considered safe for use. 3.9.1.2(a)(iii) accounts for conditions such as movement of materials due to atmospheric moisture changes or minor deviations related to variations in materials which affect finished stair dimensions.

Diagram a illustrates adjacent *risers* within a *flight* with minor deviations in the materials affecting the finished stair dimensions. The nominated *riser* height is exceeded by *riser* A. As a consequence *riser* height B is less than the nominated *riser* height. The difference between *riser* A and *riser* B cannot exceed 5 mm.

Diagram b illustrates an entire *flight* with minor deviations in the materials affecting the finished *riser* dimensions. In addition to the 5 mm difference permitted between adjacent *goings* or *risers*, the maximum difference between the smallest and largest *going* or *riser* within a *flight* must not exceed 10 mm.

Despite the deviations shown in both Diagram a and Diagram b, the stairs in the *flight* are deemed constant.

Irrespective of any minor deviations permitted by 3.9.1.2(a)(iii), finished *going* and *riser* dimensions must not exceed the limitations stipulated in Table 3.9.1.1.

Minor deviations in a stairway	
Diagram a.	Deviation in adjacent risers
<p>Notes:</p> <ol style="list-style-type: none"> 1. A = larger <i>riser</i> of two adjacent <i>risers</i>. 2. B = smaller <i>riser</i> of two adjacent <i>risers</i>. 3. This diagram only shows deviations in <i>risers</i>, however the same principle can apply for <i>goings</i>. 	

Safe Movement and Access

Diagram b. Deviations over a flight

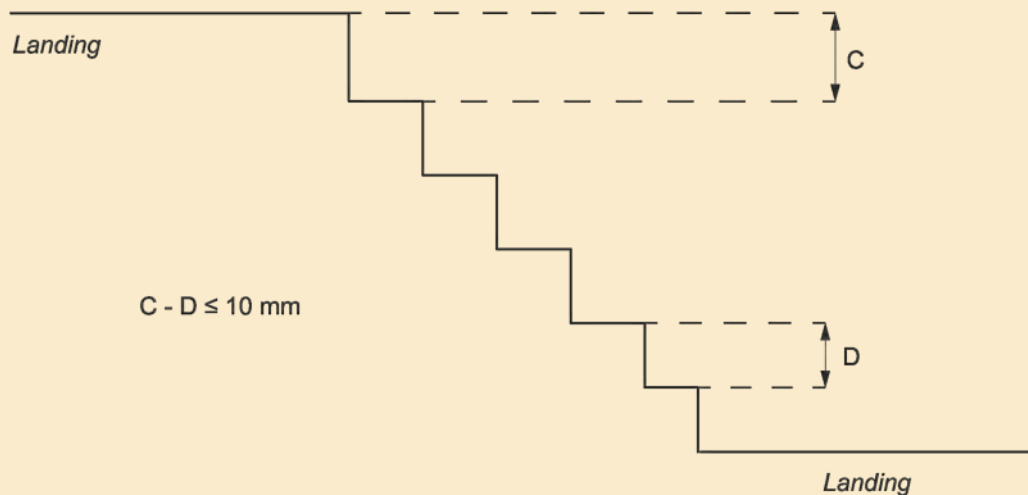
**Notes:**

1. C = largest *riser* of the *flight*.
2. D = smallest *riser* of the *flight*.
3. This diagram only shows deviations in *risers*, however the same principle can apply for *goings*.

3. **Openings in stair risers:**

3.9.1.2(a)(iv) allows the use of open *riser* stairs. However, it limits the openings to 125 mm to minimise the risk of a person (especially a young child) falling through the opening created by the open *riser*.

4. **Solid treads:**

3.9.1.2(a)(v) specifies a height where solid treads must be used so that people cannot see through them. This minimises the risk of people being affected by vertigo.

(c) In the case of a stairway with *winders*—

- (i) a maximum of 3 consecutive *winders* in lieu of a quarter *landing* in a *flight* and a maximum of 6 consecutive *winders* in lieu of a half *landing* in a *flight*; and
- (ii) the *going* (G) of all *winders* in lieu of a quarter or half *landing* may vary from the *going* of the straight treads within the same *flight* provided that the *going* (G) of such *winders* is constant.

Explanatory information:**Stairways with winders:**

1. 3.9.1.2(c) allows the use of *winders* in stairways. However, 3.9.1.2(c) places a restriction on the number of allowable *winders* in a stairway *flight*, this restriction would apply equally to not permit a stairway incorporating a consecutive series of *winders* in a *flight*.
 2. This also means the maximum number of consecutive *winders* in any stairway *flight* is 6.
- (d) The point of measurement of the *going* (G) in the slope relationship quantity (2R + G) for *tapered treads* and treads in *spiral stairways* as described in Table 3.9.1.1 (see Figure 3.9.1.1a to Figure 3.9.1.1c) must be—
- (i) for *tapered treads*, other than treads in a *spiral stairway*—
 - (A) not more than 1 m in width, the middle of the unobstructed width of the stairway (see Figure 3.9.1.1b); and
 - (B) more than 1 m in width, 400 mm from the unobstructed width of each side of the stairway (see Figure 3.9.1.1c); and
 - (ii) for treads in *spiral stairways*, the point seven tenths of the unobstructed width from the face of the centre pole or support towards the handrail side (see Figure 3.9.1.2a and Figure 3.9.1.2b).

Safe Movement and Access

Figure 3.9.1.1 Measurement of slope relationship—Plan view

Diagram a. Stair with 2 flights

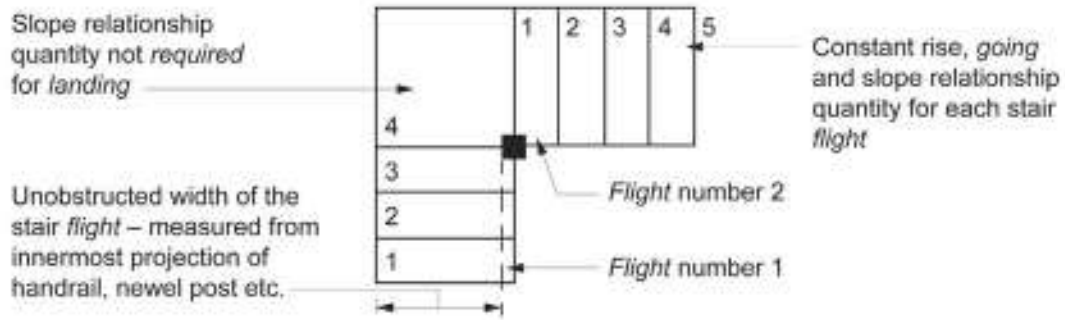

Diagram b. Tapered treads—not more than 1 m wide

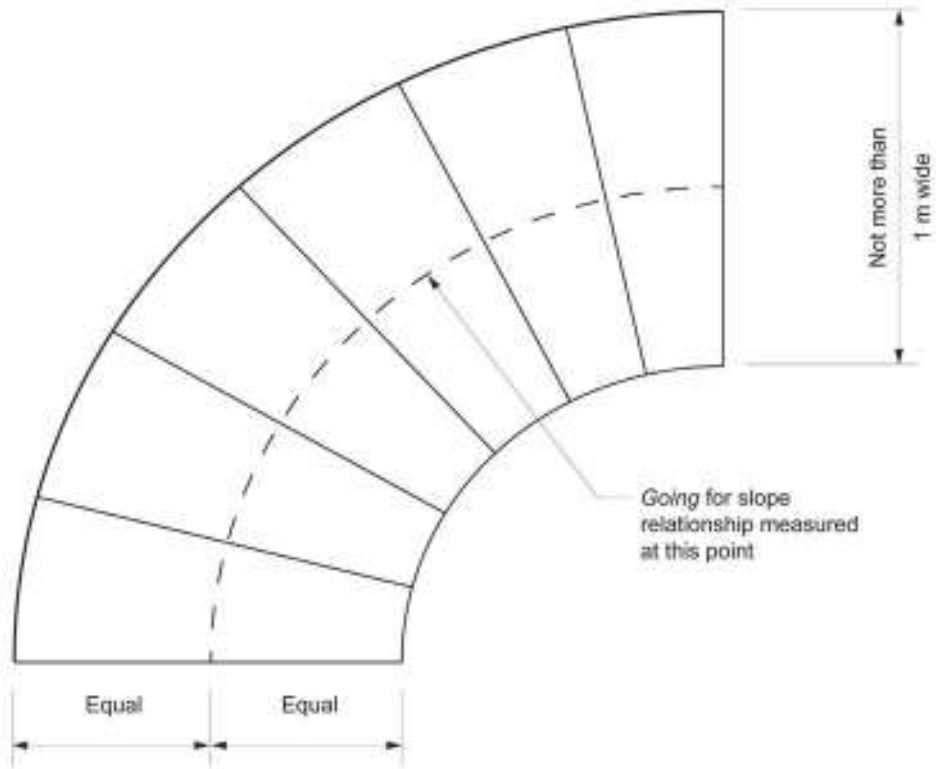

Diagram c. Tapered treads—more than 1 m wide

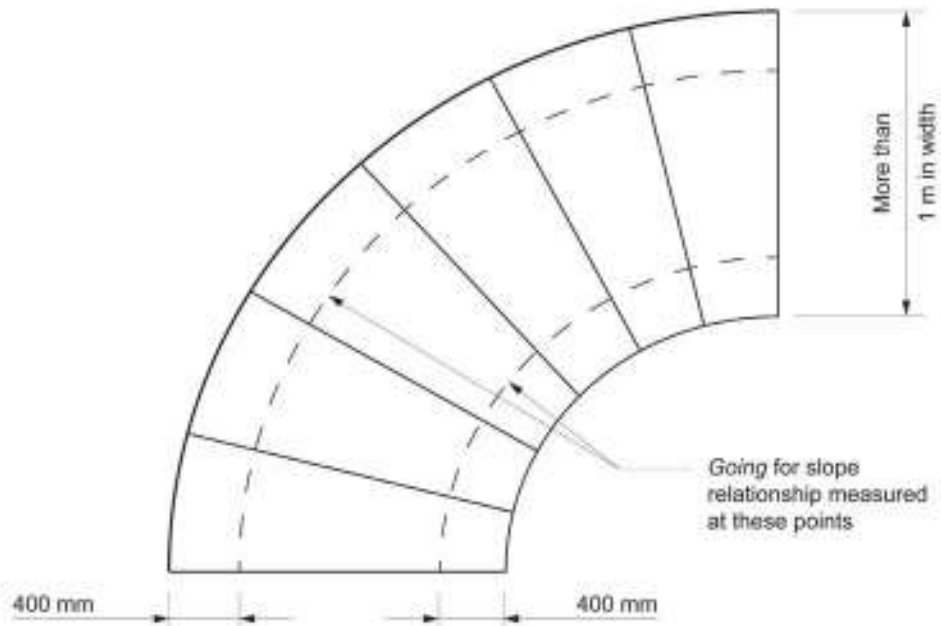

Figure 3.9.1.2 Spiral stairs

Diagram a. Measurement for slope relationship

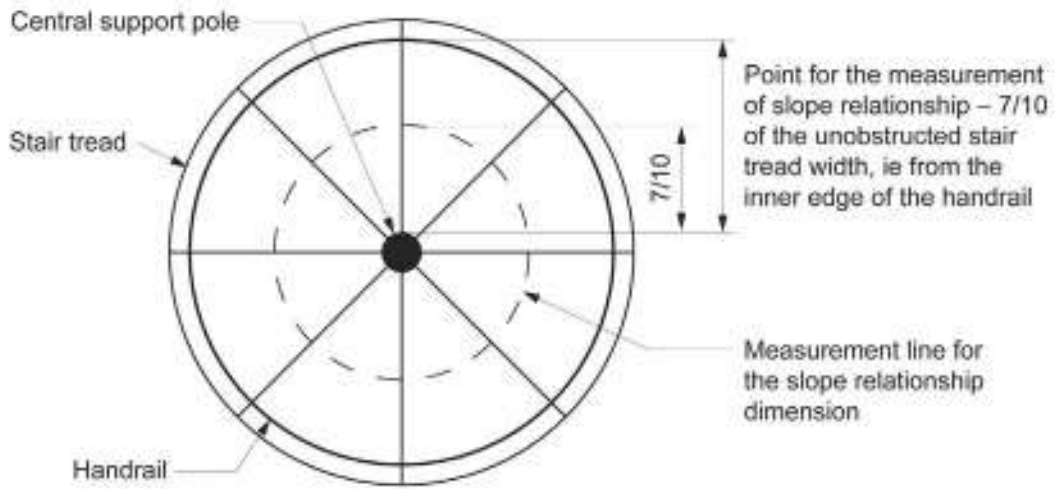
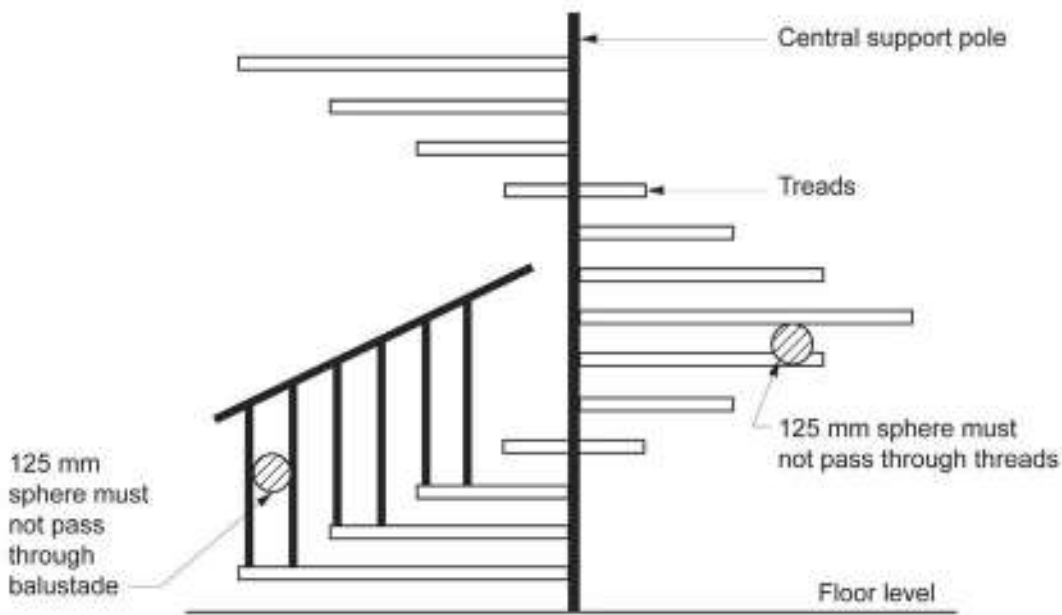

Diagram b. Measurement of openings in stairs



3.9.1.3 Ramps

An external ramp serving an external doorway or a ramp within a building must—

- (a) be designed to take loading forces in accordance with AS/NZS 1170.1; and
- (b) have a gradient not steeper than 1:8; and
- (c) be provided with *landings* complying with 3.9.1.5 at the top and bottom of the ramp and at intervals not greater than 15 m.

Explanatory information:

In relation to external ramps, 3.9.1.3 applies to a ramp serving an external door. For the purpose of 3.9.1.3 a driveway is not considered to be a ramp.

3.9.1.4 Slip-resistance

The requirements for slip-resistance treatment to stair treads, ramps and *landings* are as follows:

- (a) Treads must have—
 - (i) a surface with a slip-resistance classification not less than that listed in Table 3.9.1.3 when tested in accordance with AS 4586; or
 - (ii) a nosing strip with a slip-resistance classification not less than that listed in Table 3.9.1.3 when tested in accordance with AS 4586.
- (b) The floor surface of a ramp must have a slip-resistance classification not less than that listed in Table 3.9.1.3 when tested in accordance with AS 4586.
- (c) *Landings*, where the edge leads to the *flight* below, must have—
 - (i) a surface with a slip-resistance classification not less than that listed in Table 3.9.1.3 when tested in accordance with AS 4586, for not less than 190 mm from the stair nosing; or
 - (ii) a nosing strip with a slip-resistance classification not less than that listed in Table 3.9.1.3 when tested in accordance with AS 4586.

Table 3.9.1.3 Slip-resistance classification

Application	Dry surface conditions	Wet surface conditions
Ramp not steeper than 1:8	P4 or R10	P5 or R12

Safe Movement and Access

Application	Dry surface conditions	Wet surface conditions
Tread surface	P3 or R10	P4 or R11
Nosing or landing edge strip	P3	P4

Explanatory information:

1. To determine the appropriate surface of a tread or the floor surface of a ramp, it is necessary to determine the likely conditions the tread or ramp will be subject to over the life of the building. This can be either dry, wet or both. A dry surface is one that is not normally wet or likely to be made wet other than by an accidental spill. A wet surface is one that is normally wet or likely to be made wet, including areas exposed to the weather.
2. Under 3.9.1.4(a) stair treads must have a surface or nosing strip which minimises the risk of people slipping and injuring themselves. In each case the surface or nosing must have a slip-resistance classification when tested in accordance with AS 4586. There are two tests (the Wet Pendulum Test or the Oil-Wet Inclining Platform Test) and two conditions (dry or wet) to be considered.
3. Under 3.9.1.4(b) the floor surface of a ramp must be slip-resistant to minimise the risk of people slipping and injuring themselves. The surface must have a slip-resistance classification when tested in accordance with AS 4586.

3.9.1.5 Landings

Landings must—

- (a) be not less than 750 mm long and where this involves a change in direction, the length is measured 500 mm from the inside edge of the *landing* (see Figure 3.9.1.3a); and
- (b) have a gradient not steeper than 1:50; and
- (c) be provided where the sill of a threshold of a doorway opens onto a stairway or ramp that provides a change in floor level or floor to ground level greater than 3 risers or 570 mm (see Figure 3.9.1.3b); and
- (d) extend across the full width of a doorway; and
- (e) in the case of a stairway serving only non-*habitable rooms*, such as attics, storerooms and the like that are not used on a regular or daily basis, the requirements of (a) may be substituted with a minimum length of *landing* being not less than 600 mm long.

Explanatory information:**1. Purpose of a landing:**

The purpose of a *landing* is to provide a rest area for people using the stairway or ramp, and to allow the stairway or ramp to change direction if needed.

2. Minimum landing length:

The minimum length of a *landing* allows people using a stairway or ramp to rest, and reduces the risk of people falling more than one *flight* of stairs.

3. Maximum grade of 1:50:

The maximum grade of 1 in 50 *required* under 3.9.1.5(b) makes sure that the *landing* is as level as possible, but still allows a slight slope for drainage if necessary.

Figure 3.9.1.3a Landings

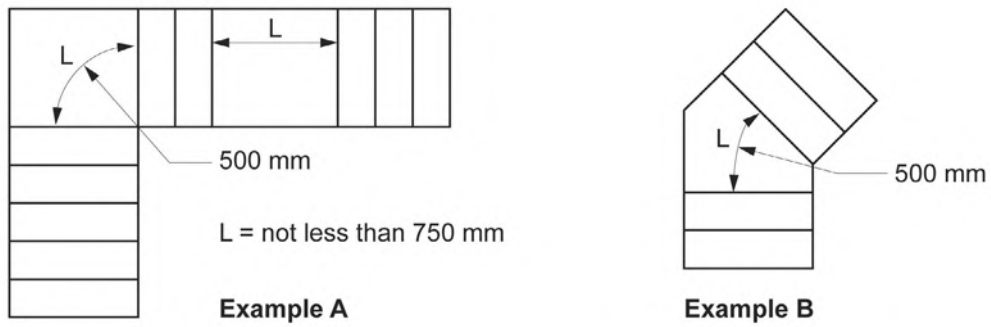
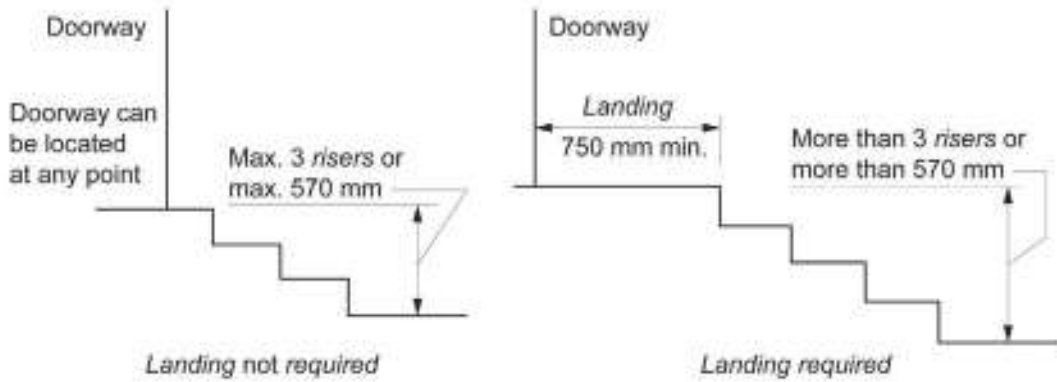

Figure 3.9.1.3b Threshold landing



3.9.1.6 Thresholds

Where the threshold of a doorway is more than 230 mm above the adjoining surface it must incorporate steps having *riser* (R) and *going* (G) dimensions in accordance with 3.9.1.2.

Part 3.9.2 Barriers and handrails

Appropriate *Performance Requirements*

- (a) Where an alternative barrier is proposed as a *Performance Solution* to that described in [Part 3.9.2](#), that proposal must comply with—
 - (i) *Performance Requirement P2.5.2*; and
 - (ii) the relevant *Performance Requirements* determined in accordance with [A2.2\(3\)](#) and [A2.4\(3\)](#) as applicable.
- (b) Where an alternative handrail is proposed as a *Performance Solution* to that described in [Part 3.9.2](#), that proposal must comply with—
 - (i) *Performance Requirement P2.5.1(b)(i)*; and
 - (ii) the relevant *Performance Requirements* determined in accordance with [A2.2\(3\)](#) and [A2.4\(3\)](#) as applicable.

The following figure depicts typical stairway and barrier members and associated terminology. Some items have been omitted for clarity.

Figure 3.9.2.0 Typical stairway and barrier members

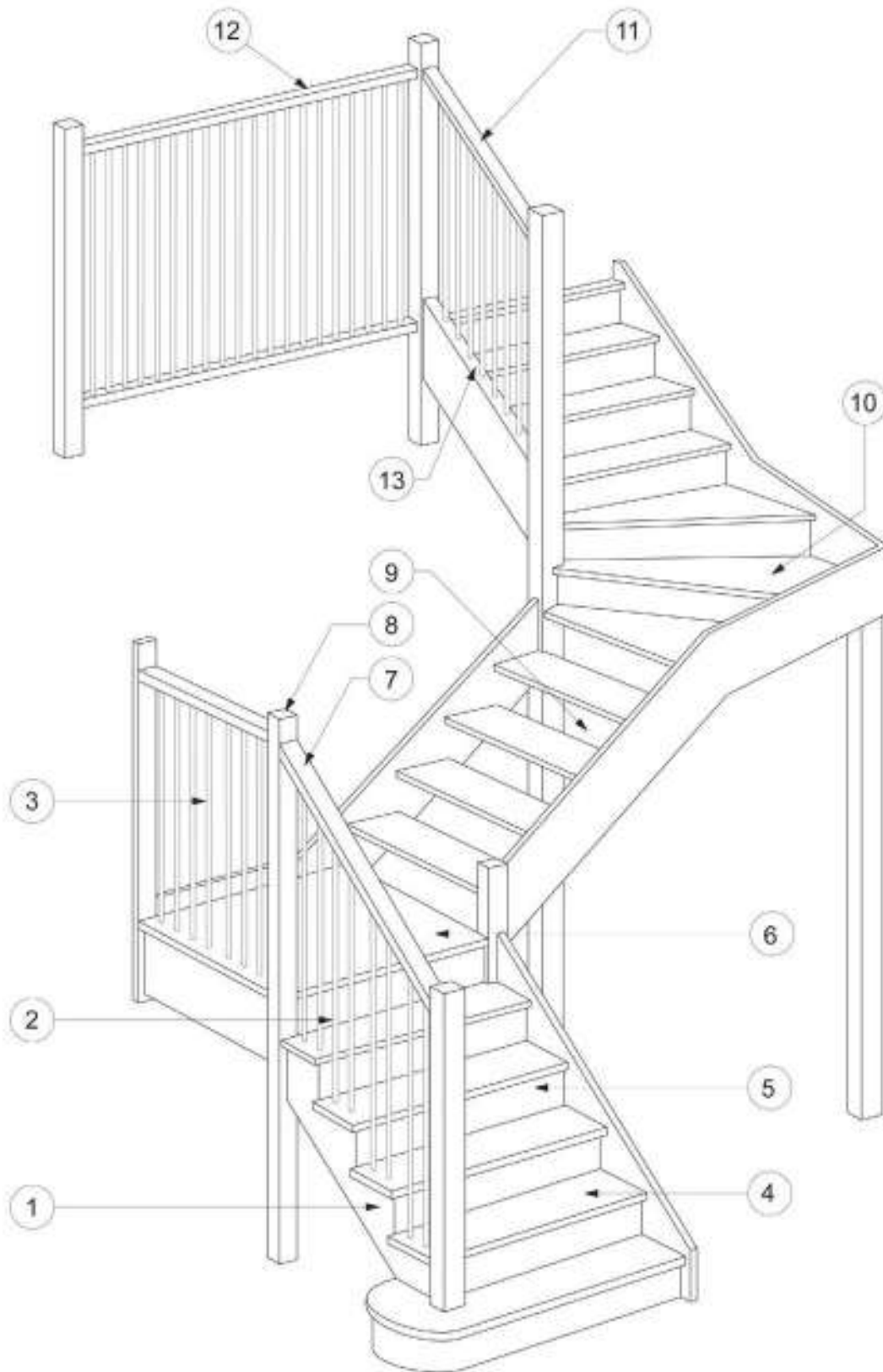

Legend:

1. Stringer

8. Newel post

Safe Movement and Access

- | | |
|-------------|------------------------------|
| 2. Baluster | 9. Open riser |
| 3. Barrier | 10. Winders (tapered treads) |
| 4. Tread | 11. Handrail |
| 5. Riser | 12. Landing barrier |
| 6. Landing | 13. Barrier |
| 7. Handrail | |

Explanatory information:

For a *required* barrier to an external trafficable structure in an *alpine area*, the requirements of this Part need to be read in conjunction with the requirements of [Part 3.10.4](#).

Safety barrier requirements for *swimming pools* are contained in [Part 3.10.1](#).

Explanatory information:

In addition to the requirements of this Part, a barrier and handrail must comply with the structural requirements of [Part 3.0](#). The structural requirements refer to the barrier and/or handrail being designed and constructed to withstand any combinations of loads and other actions to which it may reasonably be subjected and the structural resistance of the materials and forms of construction used for the barrier or handrail.

A *window* forming a part of a barrier must comply with the glazing assembly provisions of [Part 3.6](#), and therefore is not *required* to comply with AS/NZS 1170.1 (structural design actions - referenced in [Part 3.0](#)) as it is exempted by [Part 3.6](#). The [Part 3.6](#) provisions consider the wind loading on the glazing and human impact requirements.

Acceptable Construction Practice

3.9.2.1 Application

Compliance with this acceptable construction practice satisfies [Performance Requirements P2.5.2](#) for barriers and [P2.5.1\(b\)\(i\)](#) for handrails, by complying with—

- (a) [3.9.2.2](#), [3.9.2.3](#) and [3.9.2.5](#) for barriers to prevent falls; and
- (b) [3.9.2.4](#) for handrails; and
- (c) [3.9.2.6](#) and [3.9.2.7](#) for protection of openable windows.

3.9.2.2 Barriers to prevent falls

- (a) A continuous barrier must be provided along the side of a trafficable surface, such as—
 - (i) a stairway, ramp or the like; and
 - (ii) a floor, corridor, hallway, balcony, deck, verandah, mezzanine, access bridge or the like; and
 - (iii) a roof top space or the like to which general access is provided; and
 - (iv) any delineated path of access to a building, where it is possible to fall 1 m or more measured from the level of the trafficable surface to the surface beneath (see [Figure 3.9.2.1](#)).
- (b) The requirements of (a) do not apply to—
 - (i) a retaining wall unless the retaining wall forms part of, or is directly associated with a delineated path of access to a building from the road, or a delineated path of access between buildings (see [Figure 3.9.2.2](#)); or
 - (ii) a barrier provided to an openable window covered by [3.9.2.6](#) and [3.9.2.7](#).

Explanatory information:

Intent:

The intent of the barrier requirements is to prescribe provisions to minimise the risk of a person falling from a stairway, raised floor level (such as a balcony) or the like. [3.9.2.2](#) sets out when barriers are *required* to be provided and [3.9.2.3](#) contains the requirements for the construction of barriers.

Barriers and children:

Safe Movement and Access

Children are at particular risk of falling off, over or through ineffectively designed or constructed barriers. Accordingly the requirements of this Part aim to ensure that a barrier reduces the likelihood of children being able to climb over a barrier or fall through a barrier.

Figure 3.9.2.1 Barriers—when required

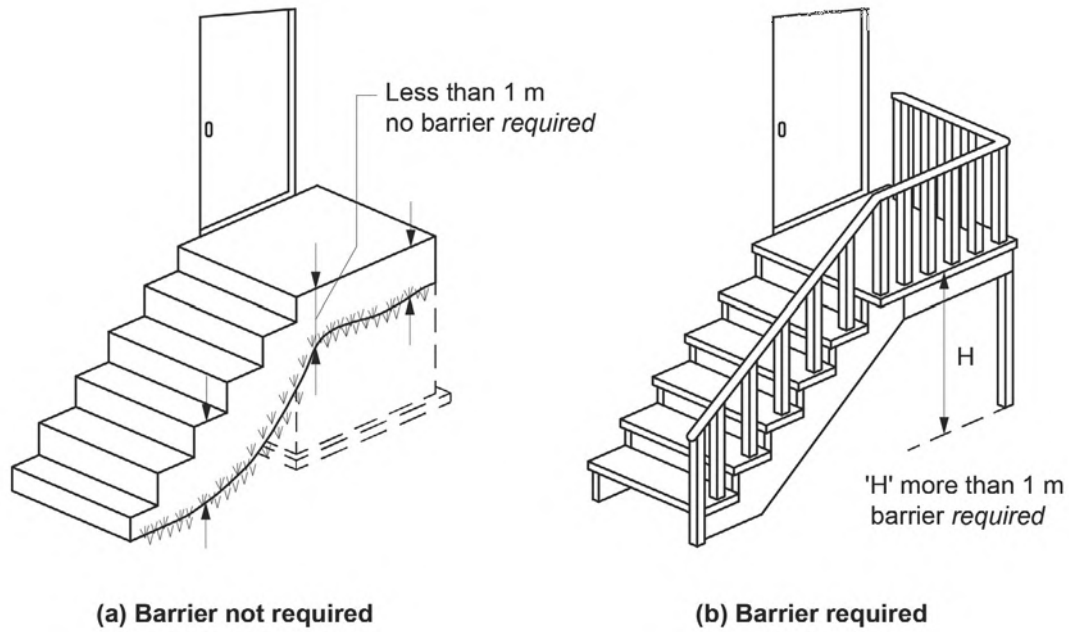
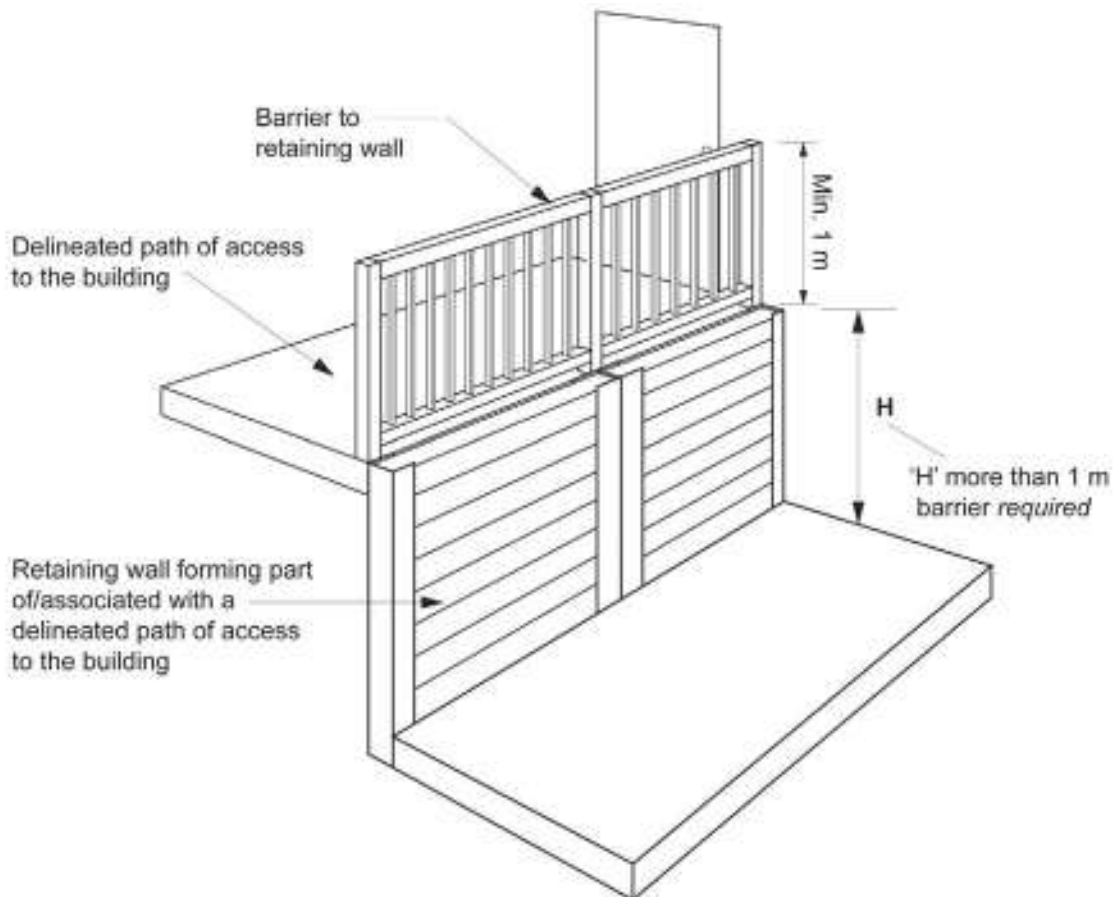

Figure 3.9.2.2 Barriers—when required for retaining walls



3.9.2.3 Construction of barriers to prevent falls

A barrier *required* by 3.9.2.2 must comply with the following:

- (a) **Barrier height:** The height of a barrier must be in accordance with the following:
 - (i) The height must not be less than 865 mm above the nosings of the stair treads, the floor of a ramp or the like (see Figure 3.9.2.3).
 - (ii) The height must not be less than—
 - (A) 1 m above the floor of any *landing*, corridor, hallway, balcony, deck, verandah, access path, mezzanine, access bridge, roof top space or the like to which general access is provided (see Figure 3.9.2.2 and Figure 3.9.2.3); or
 - (B) 865 mm above the floor of a *landing* to a stairway or ramp where the barrier is provided along the inside edge of the *landing* and does not exceed a length of 500 mm.
- (b) **Transition zone:** A transition zone may be incorporated where the barrier height changes from 865 mm on the stairway *flight* or ramp to 1 m at the *landing* (see Figure 3.9.2.4).
- (c) **Openings in barriers:** Openings in barriers (including decorative balustrades) must be constructed so that they do not permit a 125 mm sphere to pass through it and for stairways, the opening is measured above the nosing line of the stair treads (see Figure 3.9.2.3).
- (d) **Barriers to certain non-habitable rooms:** A barrier to a stairway serving a non-*habitable room*, such as an attic, storeroom or the like that is not used on a regular or daily basis, need not comply with (c) if—
 - (i) openings are constructed so that they do not permit a 300 mm sphere to pass through; or
 - (ii) where rails are used, the barrier consists of a top rail and an intermediate rail, with the openings between rails not more than 460 mm.
- (e) **Restriction on horizontal elements:**
 - (i) Where it is possible to fall more than 4 m, any horizontal elements within the barrier between 150 mm and 760 mm above the floor must not facilitate climbing.
 - (ii) For the purpose of (i), the 4 m is measured from the floor level of the trafficable surface to the surface beneath.

Explanatory Information:

For a *window* forming part of a barrier, any horizontal elements such as a *window* sill, transom or rail between 150 mm and 760 mm above the floor is deemed to facilitate climbing.

- (f) **Wire barriers:** A barrier constructed of wire is deemed to meet the requirements of (c) if it is constructed in accordance with 3.9.2.5.
- (g) **Glass barriers and a window forming part of a barrier:** A glass barrier or *window* serving as a barrier must comply with Part 3.6 and the relevant provisions of this Part.

Explanatory information:

Part 3.6 contains the glazing assembly provisions for glass barriers and *windows* forming part of the barrier, however, the barrier would still need to comply with the relevant requirements of this Part for *required* height, allowable openings, etc.

- (h) **Barrier loading forces:** A barrier, except a *window* serving as a barrier, must be designed to take loading forces in accordance with AS/NZS 1170.1.

Figure 3.9.2.3 Barrier construction

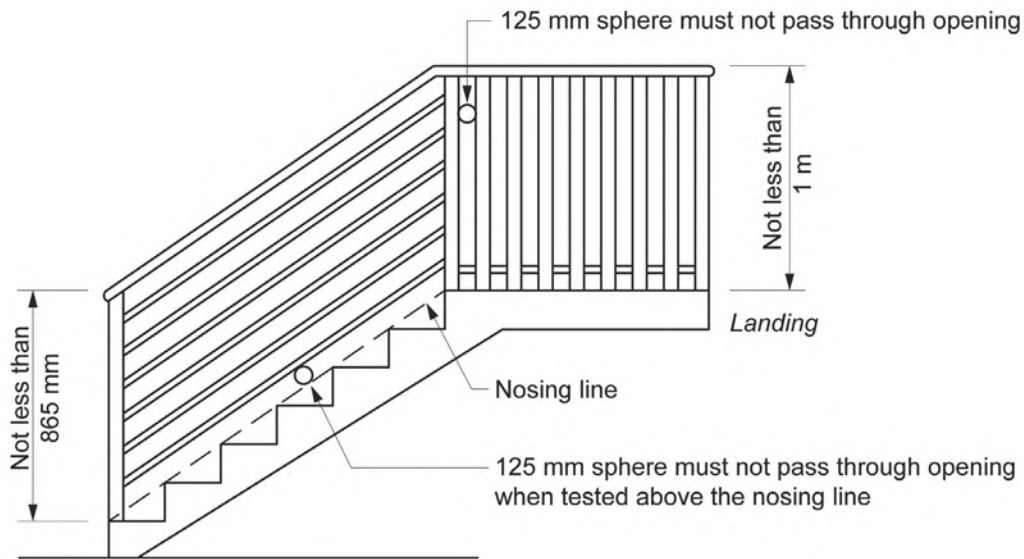
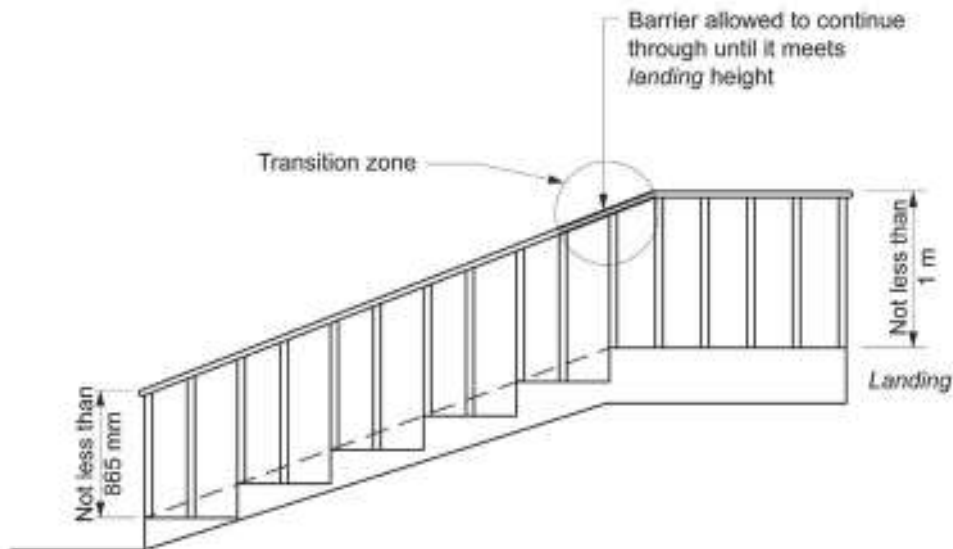

Figure 3.9.2.4 Measuring heights for barriers and handrails and where transition zones are allowed



3.9.2.4 Handrails

- (a) Handrails to a stairway or ramp must—
- (i) be located along at least one side of the stairway *flight* or ramp; and
 - (ii) be located along the full length of the stairway *flight* or ramp, except in the case where a handrail is associated with a barrier the handrail may terminate where the barrier terminates; and
 - (iii) have the top surface of the handrail not less than 865 mm vertically above the nosings of the stair treads or the floor surface of the ramp (see Figure 3.9.2.4); and
 - (iv) be continuous and have no obstruction on or above them that will tend to break a handhold, except for newel posts, ball type stanchions, or the like.
- (b) The requirements of (a) do not apply to—
- (i) a stairway or ramp providing a change in elevation of less than 1 m; or

Safe Movement and Access

- (ii) a *landing*; or
- (iii) a *winder* where a newel post is installed to provide a handhold.

Explanatory information:

1. 3.9.2.4 addresses requirements regarding location, height and extent of handrails. Where a barrier and handrail are installed together, 3.9.2.4 is to be read in conjunction with 3.9.2.2, 3.9.2.3 and 3.9.2.5.
2. A handrail is *required* on at least one side of the stairway *flight* or ramp. The top rail of a barrier may be suitable as a handrail if it meets 3.9.2.4 and is able to be grasped by hand to provide support to the person using the stairway or ramp.
3. 3.9.2.4(a)(ii) requires a continuous handrail which must extend the full length of the stairway *flight* or ramp except where the handrail is associated with the barrier, in which case the handrail can terminate where the barrier is allowed to terminate. This allows for the barriers to geometric stairways such as elliptical, spiral, circular or curved stairways to finish a few treads from the bottom of the stairway.
4. 3.9.2.4(a)(iii) requires a minimum handrail height of 865 mm. This height provides comfort, stability, support and assistance for most users.
5. 3.9.2.4(b) outlines where a handrail need not be provided, this includes—
 - where a stairway or ramp is providing a change in elevation less than 1 m; or
 - a *landing* for a stairway or ramp; or
 - *winder* in a stairway if a newel post is installed to provide a handhold.

3.9.2.5 Construction of wire barriers

A wire barrier is deemed to meet the requirements of 3.9.2.3(c) if it is constructed in accordance with the following:

- (a) For a horizontal or near horizontal wire system—
 - (i) when measured with a strain indicator, it must be in accordance with the tension values in Table 3.9.2.1; or
 - (ii) when measured for a maximum permissible deflection, it must not exceed the maximum deflections in Table 3.9.2.3.
- (b) For a non-continuous vertical wire system—
 - (i) when measured with a strain indicator, it must be in accordance with the tension values in Table 3.9.2.1 (see Note 4); or
 - (ii) when measured for maximum permissible deflection, it must not exceed the maximum deflections in Table 3.9.2.3.
- (c) For a continuous vertical or continuous near vertical sloped wire system—
 - (i) it must have wires of no more than 2.5 mm diameter with a lay of 7 x 7 or 7 x 19 construction; and
 - (ii) changes in direction at support rails must pass around a pulley block without causing permanent deformation to the wire; and
 - (iii) supporting rails must be spaced of not more than 900 mm apart and be of a material that does not allow deflection that would decrease the tension of the wire under load; and
 - (iv) when the wire tension is measured with a strain indicator, it must be in accordance with the tension values in Table 3.9.2.2 when measured in the furthestmost span from the tensioning device.

Table 3.9.2.1 Wire barrier construction—Required tension for stainless steel horizontal wires

			Clear distance between posts (mm)								
			600	800	900	1000	1200	1500	1800	2000	2500
Wire dia. (mm)	Lay	Wire spacing (mm)	Minimum required tension in Newtons (N)								
2.5	7x7	60	55	190	263	415	478	823	1080	1139	x
		80	382	630	730	824	1025	1288	x	x	x
		100	869	1218	1368	x	x	x	x	x	x
2.5	1x19	60	35	218	310	402	585	810	1125	1325	x

Safe Movement and Access

			Clear distance between posts (mm)								
			600	800	900	1000	1200	1500	1800	2000	2500
Wire dia. (mm)	Lay	Wire spacing (mm)	Minimum required tension in Newtons (N)								
					80	420	630	735	840	1050	1400
		100	1140	1565	x	x	x	x	x	x	x
3.0	7x7	60	15	178	270	314	506	660	965	1168	1491
		80	250	413	500	741	818	1083	1370	1565	x
		100	865	1278	1390	1639	x	x	x	x	x
3.0	1x19	60	25	183	261	340	520	790	1025	1180	x
		80	325	555	670	785	1025	1330	1725	1980	x
		100	1090	1500	1705	1910	x	x	x	x	x
4.0	7x7	60	5	73	97	122	235	440	664	813	1178
		80	196	422	480	524	760	1100	1358	1530	2130
		100	835	1182	1360	1528	1837	2381	2811	3098	x
4.0	1x19	60	5	5	10	15	20	147	593	890	1280
		80	30	192	300	415	593	1105	1303	1435	1844
		100	853	1308	1487	1610	2048	2608	3094	3418	3849
4.0	7x19	60	155	290	358	425	599	860	1080	1285	1540
		80	394	654	785	915	1143	1485	1860	2105	2615
		100	1038	1412	1598	1785	2165	2735	x	x	x

Notes to Table 3.9.2.1:

- Lay = number of strands by the individual wires in each strand. For example a lay of 7 x 19 consists of 7 strands with 19 individual wires in each strand.
- Where a change of direction is made in a run of wire, the tensioning device is to be placed at the end of the longest span.
- If a 3.2 mm diameter wire is used, the tension figures for 3.0 mm wire are applied.
- This table may also be used for a set of non-continuous (single) vertical wires forming a barrier using the appropriate clear distance between posts as the vertical clear distance between the rails.
- X = not allowed because the *required* tension would exceed the safe load of the wire.
- Tension measured with a strain indicator.

Table 3.9.2.2 Continuous wire barrier construction—Required tension for vertical or near vertical stainless steel wires

Wire dia. (mm)	Lay	Wire spacing (mm)	Maximum clear space between rails (mm)	
			900	
			Required tension in Newtons (N)	
2.5	7 x 19	80	145	
		100	310	
		110	610	
2.5	7 x 7	80	130	
		100	280	
		110	500	

Notes to Table 3.9.2.2:

- Lay = number of strands by the number of individual wires in each strand. For example a lay of 7 x 19 consists of 7 strands with 19 individual wires in each strand.
- Vertical wires must have two pulley blocks to each 180 degree change of direction in the wire.
- Near vertical wires may only *require* one pulley block for each change of direction.

Safe Movement and Access

4. Wire tension measured with a strain indicator.
5. The table only includes 7 x 7 and 7 x 19 wires due to other wires not having sufficient flexibility to make the necessary turns.

Table 3.9.2.3 Continuous wire barrier construction—Maximum permissible deflection for stainless steel wires

		Clear distance between posts (mm)					
		600	900	1200	1500	1800	2000
Wire dia. (mm)	Wire spacing (mm)	Maximum permissible deflection of each wire when a 2 kg mass is suspended at mid span (mm)					
2.5	60	17	11	9	8	8	8
	80	7	5	5	5	X	X
3.0	60	19	13	8	7	7	7
	80	8	6	6	5	5	5
4.0	60	18	12	8	8	7	7
	80	8	6	4	4	4	4

Notes to Table 3.9.2.3

1. Where a change of direction is made in a run of wire, the 2 kg mass must be placed at the middle of the longest span.
2. If a 3.2 mm diameter wire is used, the deflection figures for a 3.0 mm wire are applied.
3. This table may also be used for a set of non-continuous (single) vertical wires forming a barrier using the appropriate clear distance between posts as the vertical clear distance between the rails. The deflection (offset) is measured by hooking a standard spring scale to the mid span of each wire and pulling it horizontally until a force of 19.6 N is applied.
4. X = not allowed because the *required* tension would exceed the safe load of the wire.
5. This table has been limited to 60 mm and 80 mm spaces for 2.5 mm, 3 mm and 4 mm diameter wires because the required wire tensions at greater spacings would require the tension to be beyond the wire safe load limit, or the allowed deflection would be impractical to measure.

Explanatory information:

1. For the purpose of 3.9.2.5, a wire barrier consists of a series of tensioned wire rope connected to either vertical or horizontal supports serving as a guard to reduce the risk of a person falling from a roof, stairway, raised floor level or the like.
2. To assist in the application of 3.9.2.5, the following terms are explained:
 - a. Continuous - where the wire spans three or more supports.
 - b. Non-continuous - where the wire only spans between two supports.
 - c. Pulley block - a device consisting of a wheel in which a wire runs around to change its direction.
 - d. Permissible deflection - is the allowable bending of the wire.
 - e. Support rails - are horizontal components of the barrier system that span across the top and bottom to provide structural support.
3. Table 3.9.2.1 and 3.9.2.2 contains tension requirements for wires in vertical and horizontal wire barrier systems with varying post spacings, wire spacings and wire types, whereas Table 3.9.2.3 contains deflection requirements for use in horizontal and vertical barrier systems. The figures contained in the tables were derived from testing the spacing combinations in order to prevent the passage of a 125 mm diameter solid cone penetrating between the wires at a predetermined force.
4. It is important to read the notes to the Tables as they provide additional information on their application to horizontal, vertical and near vertical wire barriers.
5. Wire barriers deflect under loading conditions, even when tightly tensioned. This is particularly relevant over the service life of the barrier as the wire tends to lose its tension. Therefore, care needs to be taken to ensure that wire tension will be maintained during the life of the barrier. In some situations, it may be necessary to incorporate "lock-off" devices to prevent loosening of the wire. Likewise, if a threaded anchor bears against a soft wood post or rail, the anchor may indent the post or rail, thus loosening the wire.

Safe Movement and Access

6. Temperature effects on the tension of the wire may be significant but there is little that can be done to allow for temperature variation in service. The shorter the wire span, the lesser the effect will be.
7. Stainless steel wire with a lay of 1 x 19 has the greatest elastic modulus and will take up the same load with less extension than equivalent wires with other lays.
8. A wire barrier excludes wire mesh fences and the like.
9. Sharp ends of wires at terminations and swages need to be removed for the safety of children and other people. No wire end should protrude more than half the diameter of the wire from the swage or termination fitting.
10. It should be noted that 3.9.2.5 is only one form of compliance solution which can be used to demonstrate compliance with P2.5.2(f) and (g). The following means of verification are available:
 - a. V2.5.1.
 - b. The *Deemed-to-Satisfy Provisions* in 3.9.2.5.
 - c. A *Performance Solution* that uses one of the other NCC *Assessment Methods* which verifies that P2.5.2(f) and (g) will be achieved.

3.9.2.6 Protection of openable windows — bedrooms

- (a) A window opening in a bedroom must be provided with protection, where the floor below the window is 2 m or more above the surface beneath.
- (b) Where the lowest level of the window opening covered by (a) is less than 1.7 m above the floor, the window opening must comply with the following:
 - (i) The openable portion of the window must be protected with—
 - (A) a device capable of restricting the window opening; or
 - (B) a screen with secure fittings.
 - (ii) A device or screen *required* by (i) must—
 - (A) not permit a 125 mm sphere to pass through the window opening or screen; and
 - (B) resist an outward horizontal action of 250 N against the—
 - (aa) window restrained by a device; or
 - (bb) screen protecting the opening; and
 - (C) have a child resistant release mechanism if the screen or device is able to be removed, unlocked or overridden.
- (c) Where a device or screen provided in accordance with (b)(i) is able to be removed, unlocked or overridden, a barrier with a height not less than 865 mm above the floor is *required* to the openable window in addition to window protection.
- (d) A barrier covered by (c) must not—
 - (i) permit a 125 mm sphere to pass through it; and
 - (ii) have any horizontal or near horizontal elements between 150 mm and 760 mm above the floor that facilitate climbing (see Figure 3.9.2.5).

Figure 3.9.2.5 Protection of openable windows—bedrooms

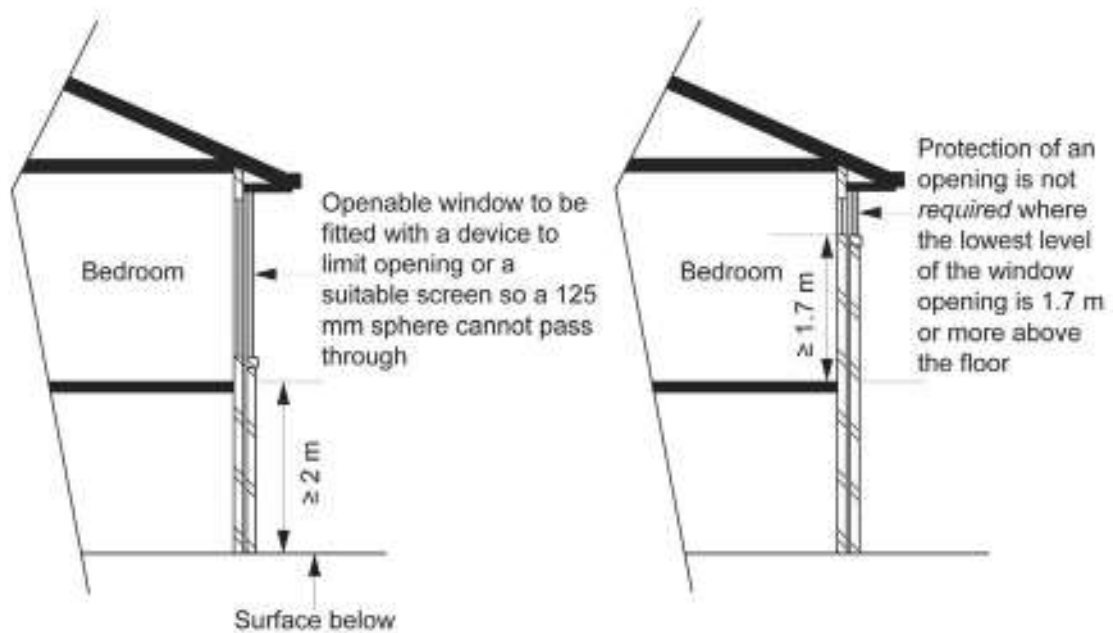

3.9.2.7 Protection of openable windows — rooms other than bedrooms

- (a) A window opening in a room other than a bedroom must be provided with protection where the floor below the window is 4 m or more above the surface beneath.
- (b) The openable part of the window covered by (a) must be protected with a barrier with a height of not less than 865 mm above the floor.
- (c) A barrier *required* by (b) must not—
 - (i) permit a 125 mm sphere to pass through it; and
 - (ii) have any horizontal or near horizontal elements between 150 mm and 760 mm above the floor that facilitate climbing.
 (See [Figure 3.9.2.6](#))

Figure 3.9.2.6 Protection of openable windows - rooms other than bedrooms

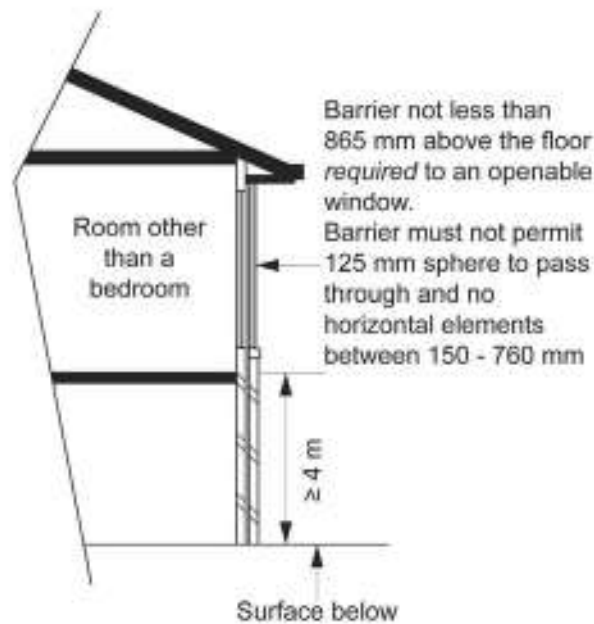

Explanatory information:

1. Intent

The intent of 3.9.2.6 and 3.9.2.7 is to reduce the risk of a person (especially a young child) falling through an openable window.

2. Protection of openable windows - bedrooms

Where the floor level below an openable window in a bedroom is less than 2 m there are no specific requirements. For an openable window 2 m or more above the surface beneath, openable windows are *required* to restrict passage of a 125 mm sphere using any one of the following design solutions:

- The window be designed such that any opening does not allow a 125 mm sphere to pass through (e.g. louvres) and be capable of resisting a 250 N force when directed against the window.
- The window be fitted with a fixed or dynamic device that is capable of restricting the window opening so it does not allow a 125 mm sphere to pass through and is difficult for a young child to operate. The restricting device must be capable of resisting a 250 N force when directed against the window such as a casement window or in attempting to push a sliding window open. An internal screen with similar parameters may be installed.
- The window be fitted with an internal or external screen that does not allow a 125 mm sphere to pass through and which must resist a horizontal outward force of 250 N.

If the openable part of the window is at least 1.7 m above the floor, no further protection is *required*.

3. Restricting devices

Where a device or screen is securely fixed in position (e.g. a screen pop riveted to the window frame) so it cannot be unlocked, overridden, or is very difficult to remove without for example a drill, the 865 mm barrier would not be *required* as the securing method is considered a fixture and not a child resistant release mechanism. 3.9.2.6(b)(ii)(C) relates to a screen or window restricting device protecting an openable window in a bedroom. The screen or opening restricting device may be installed in a manner that allows it to be removed, unlocked or overridden in the event of a fire or other emergency to allow safe egress. In these situations the unlocking device must be child resistant.

Child resistance could be achieved by the need to use a tool, key or two hands.

There are a number of hardware options available. Short chain winders and barrier screens will allow windows to comply

Safe Movement and Access

with this requirement. Sliding window locks may lock a sash so a 125 mm sphere cannot pass through. Where provision is made to fully open the window beyond 125 mm then the child resistant release mechanism is *required* in addition to the device resisting a 250 N force as *required* by 3.9.2.3(b)(ii)(B).

3.9.2.6 in addition prescribes that an 865 mm barrier (sill) would be *required*. A wall beneath an openable window or fixed glazing under the openable part of a window which meets the height requirements (e.g. transom at least 865 mm above the floor) can be considered as the barrier if the criteria in 3.9.2.6 are met.

4. Protection of openable windows - rooms other than bedrooms

A wall beneath an openable window or fixed glazing under the openable part of a window which meets the height requirements (e.g. transom at least 865 mm above the floor) can be considered as the barrier if the criteria in 3.9.2.7(b) are met.

5. Use of the term 'window'

The term "window" is not italicised in 3.9.2.6 and 3.9.2.7 and as such, is not restricted to the definition of "window" in the NCC. The reason for this is to also capture windows that may let in air but not light, e.g. metal louvres. A metal louvre or openable panel would not fit in the NCC definition of window but is subject to the window barrier provisions.

Part 3.9.3

* * * * *

The content of [Part 3.9.3](#), which existed in BCA 2016, has been relocated to a new [Part 3.10.1](#).

Part **3.10**

Ancillary Provisions and Additional Construction Requirements

- Part 3.10.1** **Swimming pools**
- Part 3.10.2** **Earthquake areas**
- Part 3.10.3** **Flood hazard areas**
- Part 3.10.4** **Construction in alpine areas**
- Part 3.10.5** **Construction in bushfire prone areas**
- Part 3.10.6** **Attachment of decks and balconies to external walls of buildings**
- Part 3.10.7** **Boilers, pressure vessels, heating appliances, fireplaces, chimneys and flues**

Part 3.10 Ancillary Provisions and Additional Construction Requirements

Part 3.10.1 Swimming pools

Acceptable Construction Manuals

3.10.1.0

Part 3.10.2 Earthquake areas

Acceptable Construction Manuals

3.10.2.0 Application

Part 3.10.3 Flood hazard areas

Acceptable Construction Manual

3.10.3.0 Application

Part 3.10.4 Construction in alpine areas

Acceptable Construction Practice

3.10.4.1 Application

3.10.4.2 External doors

3.10.4.3 External trafficable structures

3.10.4.4 Clear spaces around buildings

Part 3.10.5 Construction in bushfire prone areas

Acceptable Construction Manuals

3.10.5.0 Application

Part 3.10.6 Attachment of decks and balconies to external walls of buildings

Acceptable Construction Practice

3.10.6.1 Application

3.10.6.2 Fixing decks and balconies to external walls

3.10.6.3 Flashings to the junction of the waling plate and the external wall

3.10.6.4 Bracing

Part 3.10.7 Boilers, pressure vessels, heating appliances, fireplaces, chimneys and flues

Acceptable Construction Manuals

3.10.7.0 Application

Acceptable Construction Practice

3.10.7.1 Application

3.10.7.2 Open fireplace construction

3.10.7.3 Chimney construction

3.10.7.4 Installation of insert fireplaces and flues

3.10.7.5 Installation of free standing heating appliances

3.10.7.6 Installation of boilers and pressure vessels

Part 3.10.1 Swimming pools

Appropriate *Performance Requirements*

- (a) Where an alternative *swimming pool* safety barrier is proposed as a *Performance Solution* to that described in Part 3.10.1, that proposal must comply with—
 - (i) *Performance Requirement P2.7.1*; and
 - (i) the relevant *Performance Requirements* determined in accordance with A2.2(3) and A2.4(3) as applicable.
- (b) Where an alternative *swimming pool* water recirculation system is proposed as a *Performance Solution* to that described in Part 3.10.1, that proposal must comply with—
 - (i) *Performance Requirement P2.7.2*; and
 - (ii) the relevant *Performance Requirements* determined in accordance with A2.2(3) and A2.4(3) as applicable.

Explanatory information:

Part 3.12.5 contains requirements for *swimming pool* and spa pool heating and pumping. In specific circumstances, Part 3.12.5 requires a *swimming pool* or spa pool to have a cover to reduce evaporation and subsequent heat loss, and time switches to control the operation of the heater.

In addition to the requirements of this Part, a *swimming pool* must comply with the structural requirements of the *Housing Provisions*. The structural requirements refer to the *swimming pool* being designed and constructed to withstand any combinations of loads and other actions to which it may reasonably be subjected and the structural resistance of the materials and forms of construction used in the *swimming pool*.

Acceptable Construction Manuals

3.10.1.0

- (a) *Performance Requirement P2.7.1* is satisfied for a *swimming pool* with a depth of water more than 300 mm and which is associated with a Class 1 building, if it has safety barriers installed in accordance with AS 1926.1 and AS 1926.2.
- (b) *Performance Requirement P2.7.2* is satisfied for a water recirculation system of a *swimming pool* with a depth of water more than 300 mm, if it complies with AS 1926.3.

Explanatory information:

The BCA definition of *swimming pool* is specific in including a bathing or wading pool and a spa. The requirements of AS 1926.3 apply to all types of pools defined as *swimming pools* under the BCA, irrespective of the definition in the Standard.

The *swimming pool* water recirculation system requirements seek to minimise the risk of entrapment or injury of people using the *swimming pool* and provide for the safe operation of skimmer boxes and outlet systems.

State and Territory Variations

In New South Wales delete 3.10.1.0(a) and insert NSW 3.10.1.0(a) as follows:

- (a) *Performance Requirement P2.7.1* is satisfied for a *swimming pool* with a depth of water more than 300 mm and which is associated with a Class 1 building, if it has safety barriers installed in accordance with:
 - (i) AS 1926 Parts 1 and 2; or
 - (ii) If the *swimming pool* is a *spa pool*:
 - (A) The requirements of (a)(i); or
 - (B) Clause 9 of the Swimming Pools Regulation 2018.

Application:

NSW Part 3.10.1.0(a) applies in New South Wales to the technical construction requirements for barriers to restrict access to *swimming pools*, subject to out-of-ground pool walls and the walls of above ground pools, including inflatable pools, not being considered to be effective barriers.

Note: The Swimming Pools Act 1992 and the Swimming Pools Regulation 2018, applicable to *swimming pools* with a

Ancillary Provisions and Additional Construction Requirements

depth of water of more than 300 mm, regulate the circumstances in which a barrier is required and prevail in the case of any inconsistency.

2. Part 3.10.1.0(a) does not apply in Queensland.

Note: Restriction of access to *swimming pools* in Queensland is regulated under the Building Act 1975.

3. Part 3.10.1.0(a) does not apply in the Northern Territory.

Note: Restriction of access to *swimming pools* in the Northern Territory is regulated under the Swimming Pool Safety Act.

4. In South Australia delete 3.10.1.0(b) and add SA 3.10.1.0(b) as follows:

- (a) *Performance Requirement P2.7.2* is satisfied for a water recirculation system of a *swimming pool* with a depth of water more than 300 mm, if it complies with AS 1926.3. For the purpose of clause 6.1.1 of AS 1926.3, a skimmer box is an outlet and must have a means of releasing the vacuum pressure should the suction become blocked.

Explanatory information: Cross-volume considerations

[Part C2](#) of NCC Volume Three sets out the requirements for pumped discharge from *swimming pools*.

Part 3.10.2 Earthquake areas

Appropriate *Performance Requirements*

Where an alternative design is proposed as a *Performance Solution* to that described in [Part 3.10.2](#), that proposal must comply with—

- (a) *Performance Requirement P2.1.1*; and
- (b) the relevant *Performance Requirements* determined in accordance with [A2.2\(3\)](#) and [A2.4\(3\)](#) as applicable.

Acceptable Construction Manuals

3.10.2.0 Application

Performance Requirement P2.1.1 for Class 1 and 10 buildings constructed in areas subject to seismic activity is satisfied if the building is constructed in accordance with the acceptable construction practice in [Part 3.0](#).

Explanatory information:

1. Most domestic structures are not *required* to be specifically designed for earthquakes.
2. There are certain limitations on the application to domestic structures such as Class 1a and 1b buildings in Appendix A of AS 1170.4. These limitations include building height, roof slope, etc. For additional information refer to Appendix A of AS 1170.4.

Part 3.10.3 Flood hazard areas

Appropriate *Performance Requirements*

Where an alternative design is proposed as a *Performance Solution* to that described in [Part 3.10.3](#), that proposal must comply with—

- (a) *Performance Requirement P2.1.2*; and
- (b) the relevant *Performance Requirements* determined in accordance with [A2.2\(3\)](#) and [A2.4\(3\)](#) as applicable.

State and Territory Variations

In South Australia [Part 3.10.3](#) does not apply.

Acceptable Construction Manual

3.10.3.0 Application

Performance Requirement P2.1.2 for Class 1 buildings constructed in a *flood hazard area* is satisfied if the building is constructed in accordance with the ABCB Standard for Construction of Buildings in Flood Hazard Areas.

State and Territory Variations

3.10.3.0 does not apply in Queensland.

Note: Building work in designated *flood hazard areas* is regulated by the Building Act 1975 and the Queensland Development Code 3.5 - Construction of buildings in flood hazard areas.

In Victoria 3.10.3.0 is replaced as follows:

- (a) *Performance Requirement P2.1.2* for Class 1 buildings constructed in a *flood hazard area* is satisfied if the building is constructed in accordance with the ABCB Standard for Construction of Buildings in Flood Hazard Areas.
- (b) The definitions of *flood hazard area* and *freeboard* in the ABCB Standard for Construction of Buildings in Flood Hazard Areas are replaced with those in [Vic Schedule 3](#).
- (c) The definition of *defined flood level* in the ABCB Standard for Construction of Buildings in Flood Hazard Areas is replaced with that in [Schedule 3](#).

Part 3.10.4 Construction in alpine areas

Appropriate *Performance Requirements*

Where an alternative *alpine area* egress design is proposed as a *Performance Solution* to that described in [Part 3.10.4](#), that proposal must comply with—

- (a) *Performance Requirement P2.7.4*; and
- (b) the relevant *Performance Requirements* determined in accordance with [A2.2\(3\)](#) and [A2.4\(3\)](#) as applicable.

Explanatory information:

Buildings constructed in *alpine areas* need special consideration because of sub-zero temperatures which can create elements which restrict free movement to and from the building. The additional measures in this Part include—

- having external doorways open in a way that is not impeded by snow and ice outside; and
- for external trafficable structures forming part of the means of egress, being constructed so that they remain useable under snow conditions, and
- minimising the impact of snow build up between and around buildings.

[Part 3.0](#) (structural provisions) and [Part 3.12](#) (energy efficiency) also contain specific additional requirements for a building located in an *alpine area*.

Acceptable Construction Practice

3.10.4.1 Application

- (a) Compliance with this acceptable construction practice for buildings that are located in *alpine areas* satisfies *Performance Requirement P2.7.4*.
- (b) The *Deemed-to-Satisfy Provisions* of this Part apply in addition to other *Deemed-to-Satisfy Provisions* of the *Housing Provisions*.
- (c) Where any *Deemed-to-Satisfy Provisions* are in conflict, the provisions of this Part take precedence.

3.10.4.2 External doors

External doors that may be subject to a build-up of snow must—

- (a) open inwards or slide; and
- (b) be constructed so that the threshold is not less than 900 mm above the adjoining surface; and
- (c) in a Class 1b building, be marked “OPEN INWARDS” on the inside face of the door in letters not less than 75 mm high and in a colour contrasting with that of the background.

3.10.4.3 External trafficable structures

External stairways, ramps, access bridges or other trafficable structures serving the building must have—

- (a) a floor surface that consists of expanded mesh if it is used as a means of egress; and
- (b) any *required* barrier designed so that its sides are not less than 75% open; and
- (c) for a stairway, *goings* (G), *risers* (R) and slope relationship quantity ($2R + G$) in accordance with—
 - (i) [Table 3.9.1.1](#); or
 - (ii) [Table 3.10.4.1](#); and
- (d) for a ramp serving an external doorway, a gradient not steeper than 1:12.

Ancillary Provisions and Additional Construction Requirements

Table 3.10.4.1 Alternative stair riser and going dimensions

Maximum <i>ris-ers</i> (R) (mm)	Minimum <i>ris-ers</i> (R) (mm)	Maximum <i>going</i> (G) (mm)	Minimum <i>going</i> (G) (mm)	Maximum slope relationship (2R + G) (mm)	Minimum slope relationship (2R + G) (mm)
150	115	375	355	675	605

3.10.4.4 Clear spaces around buildings

A building must be constructed so that—

- (a) for any *external walls* more than 3.6 m above the natural ground level, the distance of that part of the building from the allotment boundary (other than a road alignment) must be not less than 2.5 m plus an additional 100 mm for each 300 mm or part by which that part of the *external wall* exceeds a height of 3.6 m (see [Figure 3.10.4.3a](#)); and
- (b) if an external doorway discharges into a court between wings of a building and that area may be used for vehicle access to the building, the clear distance between wings must be not less than 4 m (see [Figure 3.10.4.3b](#)); and
- (c) where an external doorway discharges opposite a feature that could trap snow or an embankment that is more than 900 mm above the threshold of that doorway, a minimum clear distance of not less than 4 m must be provided between the door and the feature (see [Figure 3.10.4.3c](#)).

Figure 3.10.4.3a Clear spaces around buildings—Set-back from allotment boundary where wall exceeds 3.6 m

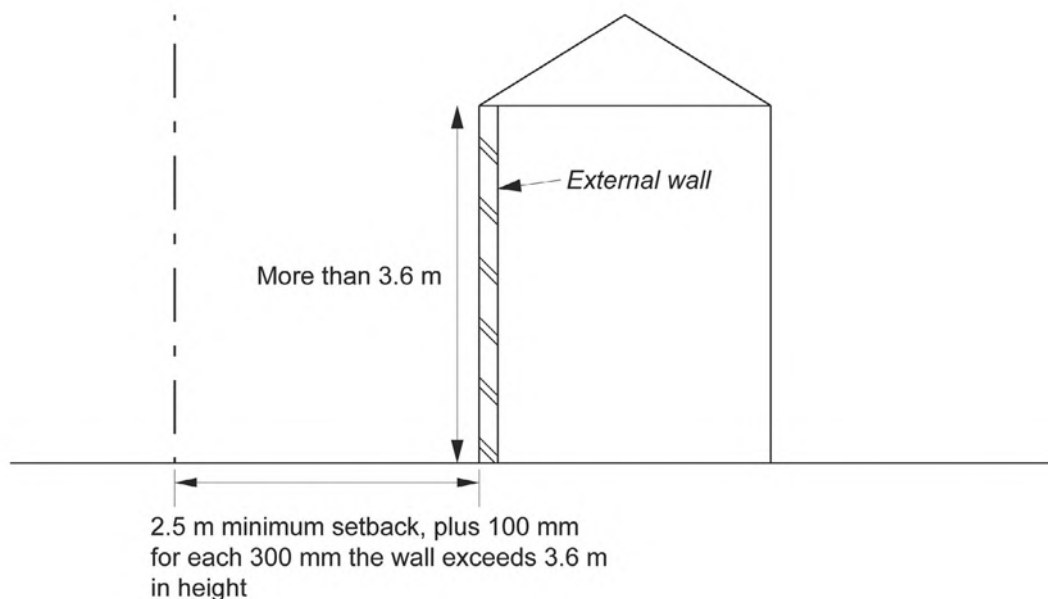

Ancillary Provisions and Additional Construction Requirements

Figure 3.10.4.3b Clear spaces around buildings—External doorway discharging into a court between wings of a building

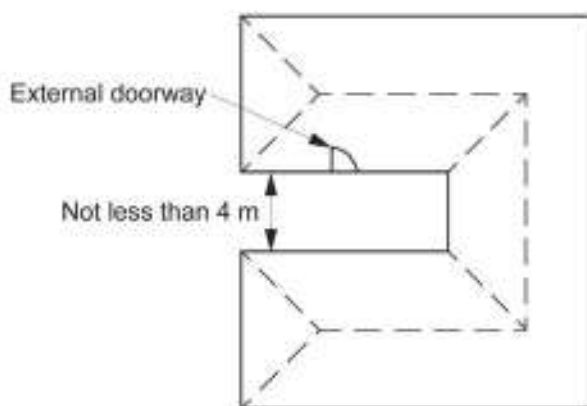

Figure 3.10.4.3c Clear spaces around buildings—Embankments adjoining buildings

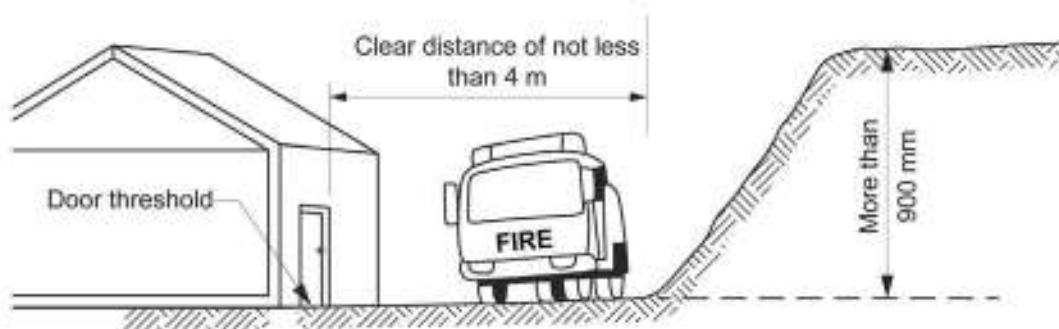
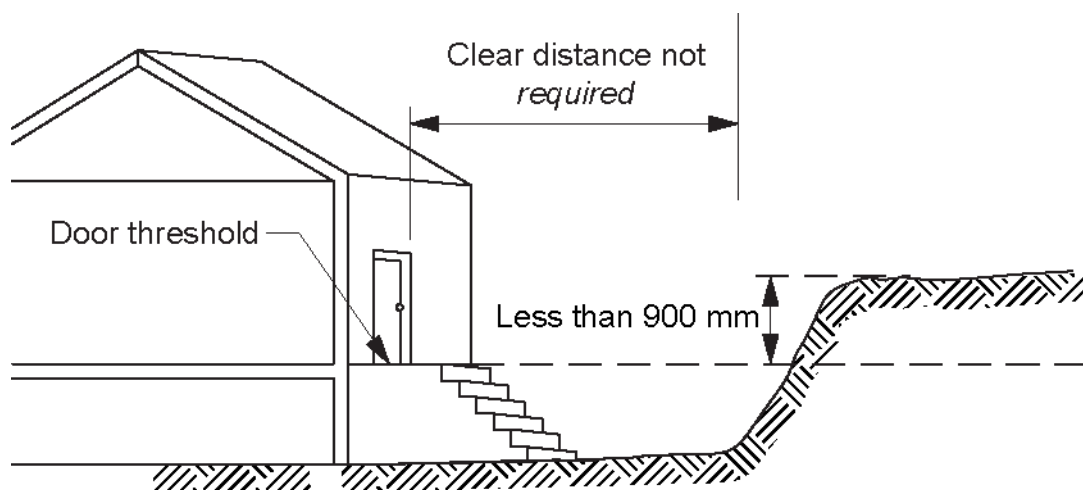

Figure 3.10.4.3d Clear spaces around buildings—Use of a threshold where clear space is not available



Explanatory information:

Snow build-up around buildings

The design and construction of a building in an *alpine area* must not aid dangerous levels of snow build-up between and around buildings. This control—

- assists with egress in an emergency; and
- helps vehicle access around the buildings, both for snow clearing and emergency situations; and
- minimises the risk of snow or ice falling from the roof onto adjoining lots or egress routes.

Ancillary Provisions and Additional Construction Requirements

1. Set-back distances

3.10.4.3(a) prescribes set-back requirements for *external walls* from the boundary of adjoining allotments. The aim is to ensure that a reasonable distance is created between buildings to reduce the amount of snow build-up between properties. 3.10.4.3(a) applies only to the area adjacent to that part of the wall that is more than 3.6 m in height.

2. Distance between wings of buildings

3.10.4.3(b) prescribes a minimum distance between wings of a building or attached buildings where external doorways may discharge into this area. This requirement only applies where the court or wings are able to be accessed by vehicles.

3. Embankments adjoining buildings

3.10.4.3(c) applies where features adjacent to an external doorway could trap snow and complicate access and egress to and from the building.

Part 3.10.5 Construction in bushfire prone areas

Appropriate *Performance Requirements*

Where an alternate bushfire protection design is proposed as a *Performance Solution* to that described in [Part 3.10.5](#), that proposal must comply with—

- (a) *Performance Requirement P2.7.5*; and
- (b) The relevant *Performance Requirements* determined in accordance with [A2.2\(3\)](#) and [A2.4\(3\)](#) as applicable.

Acceptable Construction Manuals

3.10.5.0 Application

Performance Requirement P2.7.5 is satisfied for—

- (a) a Class 1 building; or
- (b) a Class 10a building or deck associated with a Class 1 building, located in a *designated bushfire prone area* if it is constructed in accordance with—
- (c) AS 3959; or
- (d) NASH Standard – Steel Framed Construction in Bushfire Areas.

State and Territory Variations

3.10.5.0 is replaced with the following clause in New South Wales:

Performance Requirement P2.7.5 is satisfied, for—

- (a) a Class 1 building; or
- (b) a Class 10a building or deck associated with a Class 1 building, located in a *designated bushfire prone area*, if it is constructed in accordance with the following:
 - (c) AS 3959 except—
 - (i) as amended by *Planning for Bush Fire Protection*; and
 - (ii) for Section 9 for Bushfire Attack Level FZ (BAL-FZ).
 - (d) NASH Standard – Steel Framed Construction in Bushfire Areas except—
 - (i) as amended by *Planning for Bush Fire Protection*; *and*
 - (ii) for buildings subject to Bushfire Attack Level FZ (BAL-FZ).
- (e) the requirements of (c), or (d) above as modified by the development consent following consultation with the NSW Rural Fire Service under section 4.14 of the Environmental Planning and Assessment Act 1979 if required; or
- (f) the requirements of (c), or (d) above as modified by development consent with a bushfire safety authority issued under section 100B of the Rural Fires Act 1997 for the purposes of integrated development.

Explanatory information:

In New South Wales, buildings subject to BAL-FZ must comply with specific conditions of development consent for construction at this level.

3.10.5.0 is replaced with the following clause in Queensland:

- (a) Subject to (b), *Performance Requirement P2.7.5* is satisfied for—
 - (i) a Class 1 building; or
 - (ii) a Class 10a building or deck associated with a Class 1 building, located in a *designated bushfire prone area* if it is constructed in accordance with—
 - (i) AS 3959; or
 - (ii) NASH Standard – Steel Framed Construction in Bushfire Areas.
- (b) The requirements of (a) do not apply when, in accordance with AS 3959, the classified vegetation is Group F rainforest (excluding wet sclerophyll forest types), mangrove communities and grasslands under 300 mm high.

Part 3.10.6 Attachment of decks and balconies to external walls of buildings

Appropriate *Performance Requirements*

Where an alternative method for attaching a deck or balcony to an *external wall* is proposed as a *Performance Solution* to that described in Part 3.10.6, that proposal must comply with—

- (a) *Performance Requirement P2.1.1*; and
- (b) the relevant *Performance Requirements* determined in accordance with A2.2(3) and A2.4(3) as applicable.

Acceptable Construction Practice

3.10.6.1 Application

Compliance with this acceptable construction practice satisfies *Performance Requirement P2.1.1* for the attachment of a deck or balcony to an *external wall* provided—

- (a) the deck or balcony is not located in an *alpine area*; and
- (b) the height of the deck or balcony is not more than 3 m measured from the uppermost finished floor surface of the deck or balcony at any point to the top of any supporting footing; and
- (c) the waling plate does not support—
 - (i) more than one floor; or
 - (ii) *loadbearing* or non-*loadbearing* walls; or
 - (iii) roof loads; and
- (d) the deck or balcony does not cantilever off the *external wall*; and
- (e) the total imposed load on the deck or balcony does not exceed 2 kPa; and

Explanatory information:

A 2 kPa imposed load is commensurate with domestic and residential activities associated with Class 1 buildings (e.g. dwellings with limited occupancy and restricted public access) and is not appropriate for applications where the deck or balcony supports heavy equipment, spa/bathing pools or circumstances where the deck or balcony is intended for community access (e.g. applications with a mid-high occupancy and possibility of public access).

If the design live load of the deck or balcony is more than 2 kPa, the framing members of the deck or balcony must be designed by a *professional engineer* or other *appropriately qualified person* in accordance with the relevant structural design manuals in Part 3.0.

- (f) the deck or balcony framing including member sizes, spans and spacing, bracing for racking and shear forces, fixings and structural supports complies with Part 3.0; and
- (g) the deck or balcony framing is constructed of—
 - (i) steel framing in accordance with Part 3.4.2; or
 - (ii) timber framing in accordance with Part 3.4.3; and
- (h) the *external wall* supporting the deck or balcony is constructed of—
 - (i) 190 mm thick fully core-filled concrete masonry, reinforced with vertical N12 bars at not more than 600 mm centres; or
 - (ii) steel framing complying with Part 3.4.2; or
 - (iii) timber framing complying with Part 3.4.3; and
- (i) the *external wall* referred to in (h) must be continuous from the uppermost surface of the deck or balcony to the supporting footing and contain no openings or lintels below the deck or balcony; and
- (j) the waling plate is fixed to the *external wall* in accordance with 3.10.6.2 and attached by—
 - (i) fixing the waling plate through wall cladding complying with Part 3.5.4 or Part 3.5.5, provided the cladding is directly fixed to the *external wall*; or

Ancillary Provisions and Additional Construction Requirements

- (ii) removing parts of the wall cladding so that the waling plate is directly fixed to the *external wall*, with—
 - (A) the junction of the waling plate and the *external wall* flashed in accordance with 3.10.6.3; and
 - (B) the cladding restored to its original strength by installing blocking supports as necessary on completion of installation; and

Explanatory information:

3.10.6.1(j)(ii) requires consideration to be given to restoring cladding, weatherproofing and structural properties. Other considerations include restoring the appropriate sound and thermal insulation, and the capacity to maintain an FRL where *required*.

- (k) the deck or balcony is braced to prevent longitudinal movement in accordance with 3.10.6.4.

Explanatory information:

3.10.6.1 describes the circumstances under which the methods of attachment described in this Part are deemed appropriate.

Where a deck or balcony is constructed outside the conditions listed in 3.10.6.1, e.g. attachment to a masonry veneer wall, the method of attachment to the building or structure must be designed by a *professional engineer* or other *appropriately qualified person* in accordance with the relevant structural design manuals in Part 3.0. Such a design will need to consider the suitability of the wall to withstand the loads imposed by the deck or balcony, and the capacity of the connections.

Examples of *external wall* construction that are outside the application of Part 3.10.6 include a masonry *external wall* that is not fully core-filled, cavity brick and masonry veneer construction where fasteners may be subject to withdrawal.

An alternative to attaching a deck or balcony directly to an *external wall* includes providing supporting piers, posts or columns or the like parallel to the wall line or at right angles to the wall.

3.10.6.2 Fixing decks and balconies to external walls

Where a deck or balcony relies on the *external wall* of a building or structure for support, the method of attachment, including any fixings, to the *external wall* must comply with the following:

- (a) The deck or balcony's joist framing members must be supported at the wall by a waling plate.
- (b) The joist span nearest the *external wall* must not be more than 3 m (single or continuous span).
- (c) The size of a waling plate *required* by (a) must be not less than—
 - (i) for a timber waling plate — 190 x 45 mm with a minimum stress grade of F5 or MGP10; or
 - (ii) for a steel waling plate — C15015 (minimum Grade G550) with the web located against the *external wall*.
- (d) A waling plate must be attached so that—
 - (i) for core-filled reinforced concrete masonry *external walls*, fixings are staggered along the waling plate at not more than 300 mm centres measured along the waling plate; and
 - (ii) for timber *external walls*, two fixings are provided into a solid joist or bearer framing member that is not less than 190 x 100 mm with a minimum stress grade of F5 or MGP10, at not more than 300 mm centres measured along the waling plate; and
 - (iii) for steel framed *external walls*, two fixings are provided into a joist or bearer framing member not less than C20015 (Grade G550) at not more than 300 mm centres measured along the waling plate; and
 - (iv) fixings are—
 - (A) installed within 300 mm of each end of the waling plate; and
 - (B) for a timber waling plate — not located within 120 mm from the ends or within 60 mm from the top and bottom edges; and
 - (C) for a steel waling plate — not located within 50 mm from the ends or within 30 mm from the top and bottom edges.

Explanatory Information:

Consideration needs to be given to offsetting the waling plate fastener spacing to avoid interference with joist attachment. To ensure fasteners are positively anchored to the building or structure they need to be located so that they are not fixed into mortar beds between masonry units or fixed into blocking or the end grains of timbers.

Ancillary Provisions and Additional Construction Requirements

An I-beam is not considered a solid joist or bearer framing member under 3.10.6.2(d)(ii) and is therefore not permitted as an appropriate method of support for attachment of a deck or balcony to an *external wall*.

- (e) Fixings for attaching a waling plate to an *external wall* must be—
- (i) for timber *external wall* frames with a minimum stress grade of F5 or MGP 10—
 - (A) M12 coach screws with not less than 3 mm thick 55 mm diameter washers fixed so that the coach screw is embedded not less than 96 mm into the joist or bearer framing member (see Figure 3.10.6.1b); or
 - (B) 4.6/S M12 bolts with not less than 3 mm thick 55 mm diameter washers placed on the waling plate under the bolt head; and
 - (ii) for steel *external wall* frames, 8.8/S M12 bolts with not less than 3 mm thick 55 mm diameter washers; and
 - (iii) for a core-filled masonry *external wall*, 4.6/S M12 chemical or expanding/mechanical anchors with—
 - (A) a minimum 2 kN working load capacity in shear and 1.5 kN in tension; and
 - (B) not less than 3 mm thick 55 mm diameter washers placed on the waling plate under the anchor head (see Figure 3.10.6.1a).
- (f) Fixings used for attaching waling plates to *external walls* must be—
- (i) stainless steel where the building is located within 200 m of *breaking surf*; or
 - (ii) hot-dipped galvanised, stainless steel or monel metal for all other areas.

Explanatory information:

The working load capacity of an anchor *required* by 3.10.6.2(e)(iii)(A) may be available in technical data provided by the manufacturer of the anchor.

The bolt category 4.6/S refers to a commercial bolt of a strength grade of 4.6 using a snug tight method of tensioning. AS 4100 contains information on tensioning techniques and the methods of determining the strength of an anchor.

Where the waling plate is fixed to the *external wall* through wall cladding, fixing length must be increased to compensate for the additional width of the cladding to ensure the connection to the *external wall* is structurally adequate.

All coach screwed joints should be pre-drilled with a pilot hole whose diameter is not greater than that of the threaded portion of the screw.

3.10.6.3 Flashings to the junction of the waling plate and the external wall

Where the wall cladding is removed to attach a waling plate, openings in *external wall* cladding exposed to the weather must be flashed with materials complying with AS/NZS 2904 and in accordance with the following:

- (a) *Flashings* must be provided to bottom, tops and the sides of the junction of the waling plate and the *external wall*, and must be installed so that the *flashing*—
- (i) extends not less than 150 mm beyond each side of the waling plate where practicable; and
 - (ii) is attached to the waling plate and wall framing; and
 - (iii) at the top and bottom of the waling plate, drains to the outside face of the wall or cladding.
- (b) Joins in the *flashing* must—
- (i) overlap by not less than 75 mm in the direction of flow; and
 - (ii) be securely fastened at intervals of not more than 40 mm; and
 - (iii) have sealant installed between laps.
- (c) The method of *flashing* must be suitable for the framing and cladding used.
- (d) *Flashings* must be securely fixed at least 25 mm under the cladding at ends and edges of the framing of the opening.

Explanatory Information:

Consideration needs to be given to the method of fixing the waling plate to the *external wall* so that deterioration of the *external wall* as a result of water entry will not occur. Such cases would include where the wall cladding is removed to attach a waling plate. This may be achieved by installing flashing between the *external wall* and the waling plate.

Ancillary Provisions and Additional Construction Requirements

3.10.6.4 Bracing

Where a deck or balcony is more than 1 m off the ground when measured from the uppermost surface of the deck or balcony at any point to the top of any supporting footing, bracing must be installed as follows:

- (a) Two diagonally opposed 30 x 0.8 mm galvanized steel straps must be installed across the top or underside of the joists and be attached using one fixing at—
 - (i) each joist or equivalent framing member; and
 - (ii) the waling plate.
- (b) A secondary set of 30 x 0.8 mm steel straps must be installed using one fixing at each joist or equivalent framing member in accordance with [Figure 3.10.6.2](#) where the deck or balcony extends more than 4 m from the *external wall*.
- (c) The steel straps must—
 - (i) be continuous and extend diagonally at an angle between 30° to 60°; and
 - (ii) span not more than 4 m when measured along a line at a right angle from the *external wall*.
- (d) Fixings for the steel straps must be—
 - (i) for timber framing, 50 x 3.15 hot-dipped galvanized flat head ring shank or flat head deformed nail; or
 - (ii) for steel framing, 8-18 self embedding head or wafer head screws.
- (e) Where the deck or balcony is located within a severe corrosion environment the bracing and fixings must comply with [Table 3.4.4.7](#).

Figure 3.10.6.1a Methods of attachment — 4.6/S M12 chemical or masonry anchors into a core-filled reinforced masonry external wall

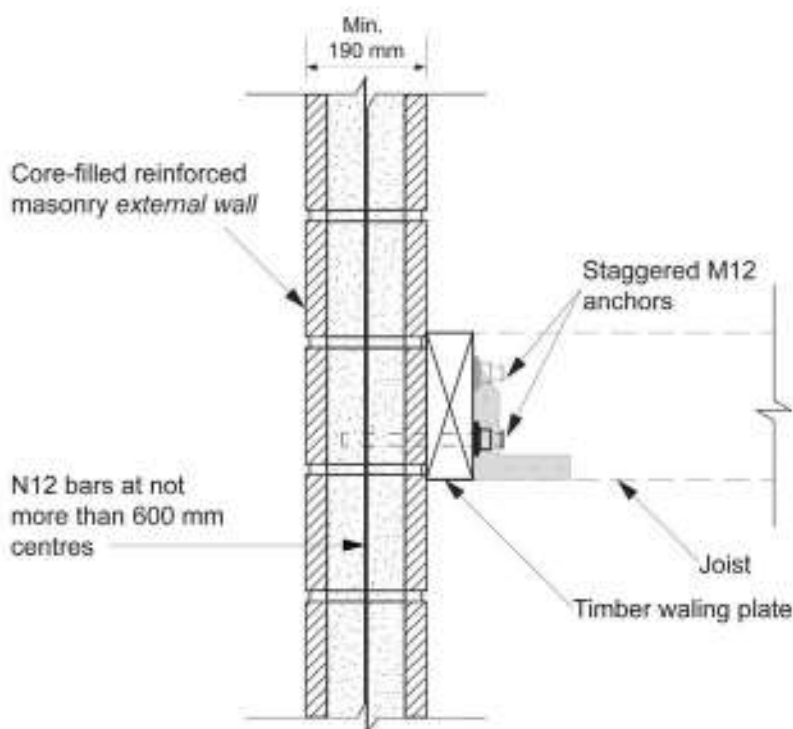

Ancillary Provisions and Additional Construction Requirements

Figure 3.10.6.1b Methods of attachment — M12 coach screws into a timber framed external wall

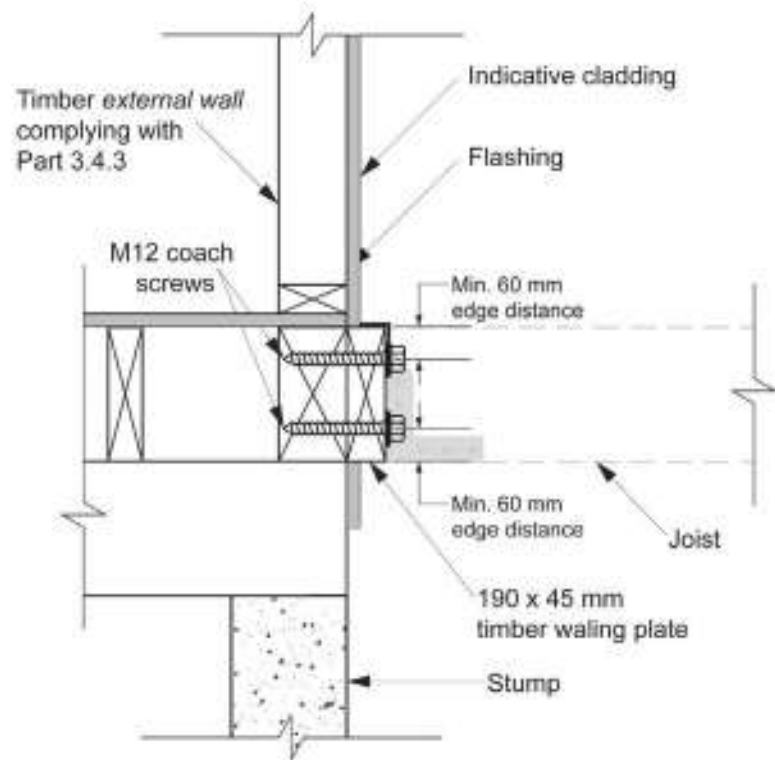
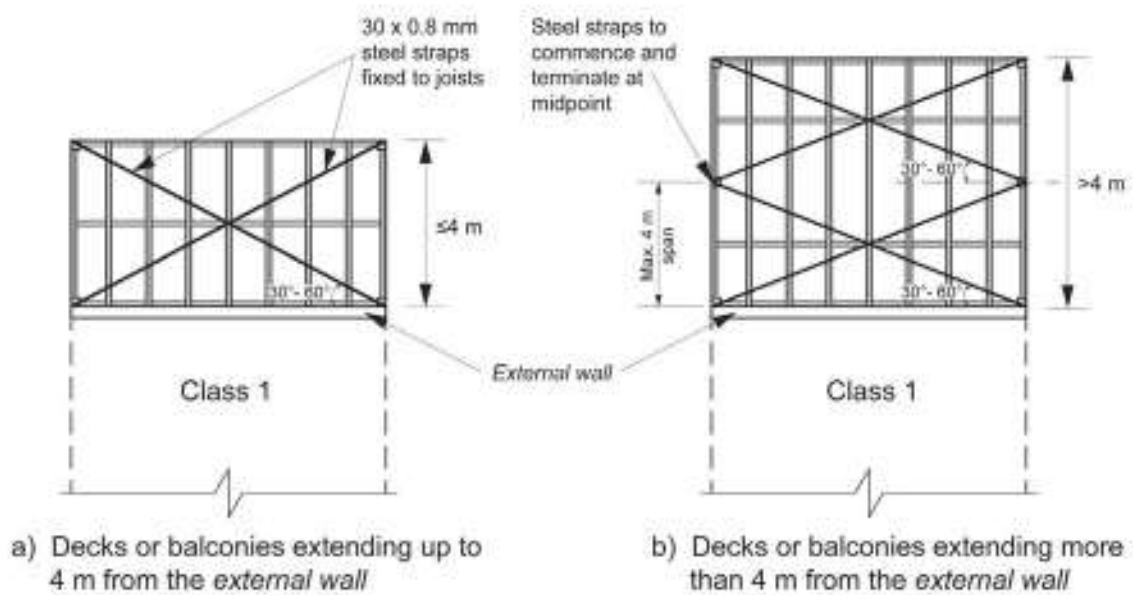

Figure 3.10.6.2 Bracing of decks and balconies



Part 3.10.7

Boilers, pressure vessels, heating appliances, fireplaces, chimneys and flues

Appropriate *Performance Requirements*

Where an alternative heating appliance is proposed as a *Performance Solution* to that described in [Part 3.10.7](#), that proposal must comply with—

- (a) *Performance Requirement P2.7.3*; and
- (b) the relevant *Performance Requirements* determined in accordance with [A2.2\(3\)](#) and [A2.4\(3\)](#) as applicable.

Acceptable Construction Manuals

3.10.7.0 Application

[Performance Requirement P2.7.3](#) is satisfied for a heating appliance if it is installed in accordance with one of the following:

- (a) * * * * *
- (b) Domestic solid-fuel burning appliances: AS/NZS 2918.

Acceptable Construction Practice

3.10.7.1 Application

Compliance with this acceptable construction practice satisfies [Performance Requirement P2.7.3](#) for heating appliances.

3.10.7.2 Open fireplace construction

An open fireplace, or solid-fuel burning appliance in which the fuel-burning compartment is not enclosed must have—

- (a) all masonry constructed in accordance with [Part 3.3](#); and
- (b) a hearth constructed of stone, concrete, masonry or similar *non-combustible* material so that—
 - (i) it extends not less than 300 mm beyond the front of the fireplace opening and not less than 150 mm beyond each side of that opening; and
 - (ii) its upper surface does not slope away from the back hearth; and
 - (iii) *combustible* material, such as flooring or framing members below the hearth, is situated not less than 150 mm from the upper surface of the hearth (see [Figure 3.10.7.1](#)); and
- (c) walls forming the sides and back of the fireplace up to a height of 300 mm above the underside of the arch or lintel which—
 - (i) are constructed in 2 separate leaves of solid masonry not less than 180 mm thick, excluding any *cavity*; and
 - (ii) do not consist of concrete block masonry in the construction of the inner leaf; and
 - (iii) are constructed of masonry units with a net volume, excluding cored and similar holes, not less than 75% of their gross volume, measured on the overall rectangular shape of the units, and with an actual thickness of not less than 100 mm; and
- (d) the fireplace must be constructed on footings complying with [3.2.5.5](#).

Ancillary Provisions and Additional Construction Requirements

Figure 3.10.7.1 Fireplace clearance from combustible materials

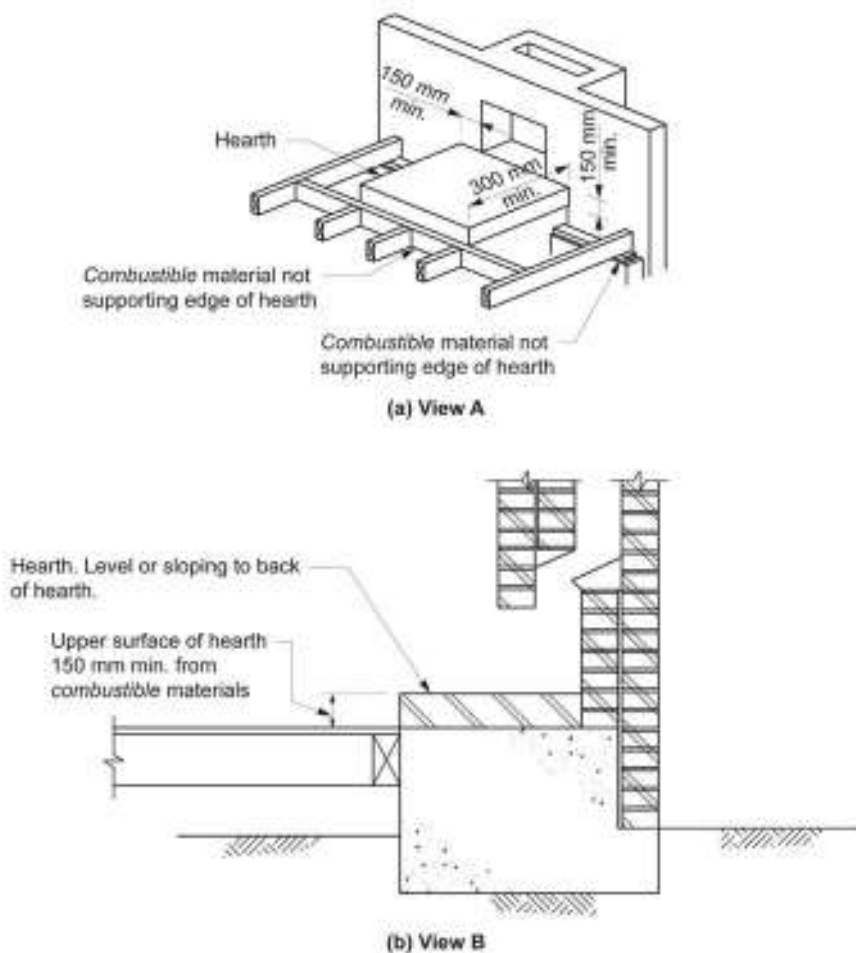

3.10.7.3 Chimney construction

The construction of a chimney must comply with [Part 3.3](#) and the following:

- The walls of the chimney above the level referred to in [3.10.7.2\(c\)](#) must be lined internally to a thickness of not less than 10 mm with composition mortar parging.
- The chimney or flue must terminate not less than 300 mm above the highest part of the building within a horizontal distance of 3.6 m of the chimney or flue (see [Figure 3.10.7.2](#)).

Explanatory information:

The requirements of this Part are to be read in conjunction with the building sealing requirements in [Part 3.12.3](#). However, it should be noted that [Part 3.12.3](#) does not apply in all States and Territories.

Figure 3.10.7.2 Section showing height and position of chimney

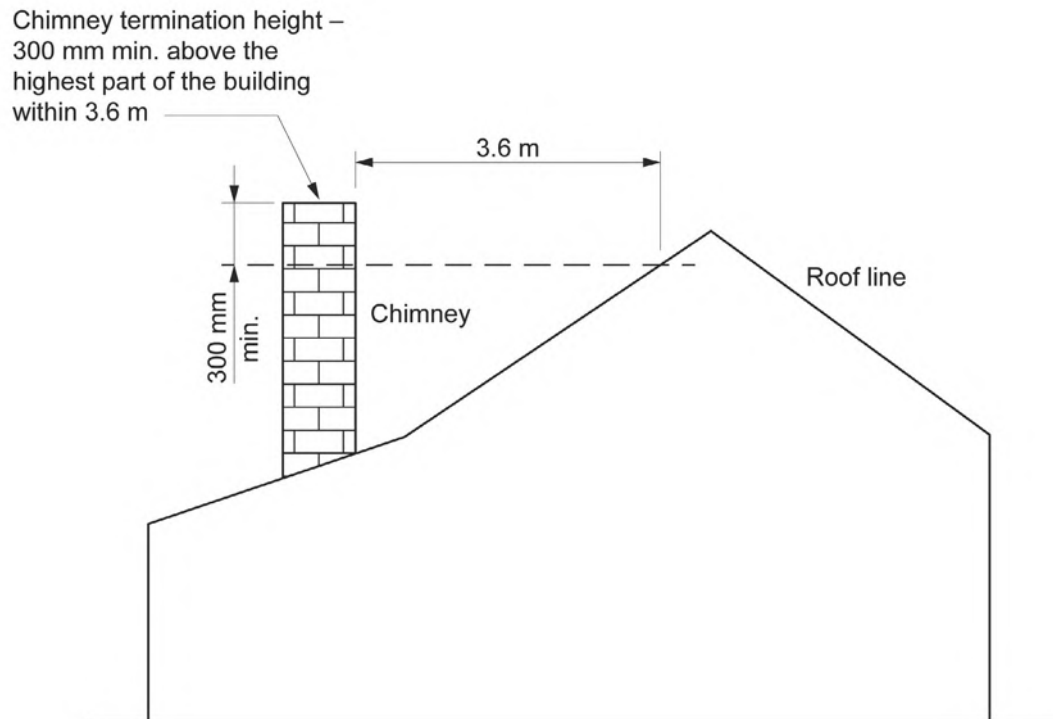

3.10.7.4 Installation of insert fireplaces and flues

An insert fireplace and flue must comply with the following:

- The insert fireplace must be tested and passed the tests required by AS/NZS 2918.
- The insert fireplace must be fitted into a masonry fireplace (including chimney) constructed in accordance with [Part 3.3](#).
- The flue must be double skin and have been tested and pass the tests required by AS/NZS 2918.

Ancillary Provisions and Additional Construction Requirements

Figure 3.10.7.3 Typical installation of fireplace flue inserts

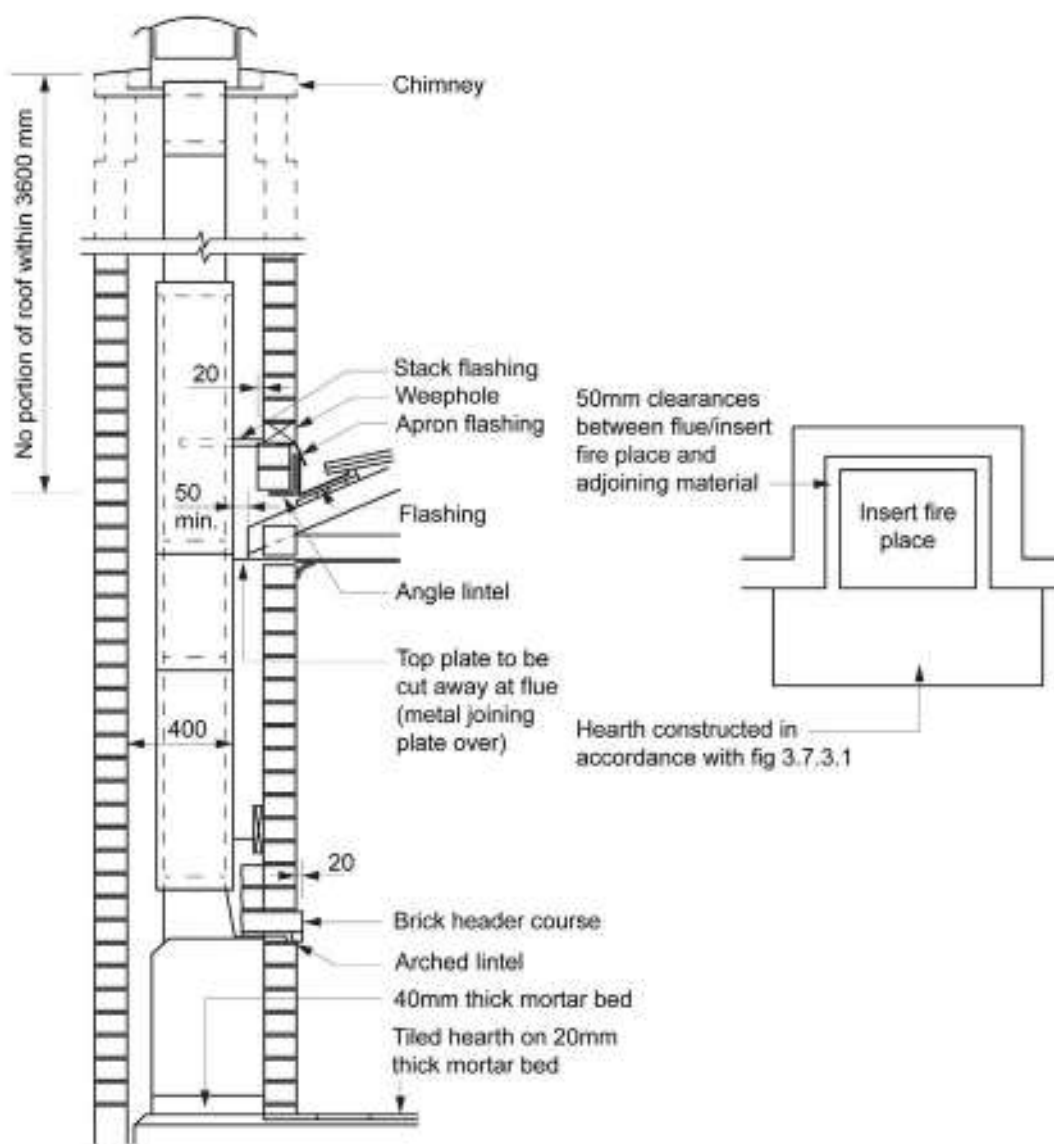

- (d) There must be a clearance of 50 mm between the outer flue and adjacent materials.
- (e) The flue must terminate in accordance with [Figure 3.10.7.2](#).
- (f) The hearth must be constructed in accordance with [3.10.7.2\(b\)](#) and (d).

3.10.7.5 Installation of free standing heating appliances

The installation of a free standing heating appliance must comply with the following:

- (a) The appliance must—
 - (i) be installed with safety clearances determined by testing in accordance with AS/NZS 2918; or
 - (ii) be located not less than 1.2 m from adjoining walls (other than a masonry wall); or
 - (iii) have a heat shield between the adjoining wall (other than a masonry wall) and the heating appliance in accordance with [Figure 3.10.7.4 Diagrams a and b](#).
- (b) Where a heat shield is used, it must be installed in accordance with [Figure 3.10.7.4 Diagram a and b](#) and it must be not less than 90 mm thick masonry constructed in accordance with [Part 3.3](#).
- (c) The heating appliance must be installed on a hearth—
 - (i) complying with [3.10.7.2\(b\)](#), except that the hearth must extend 400 mm from the appliance in accordance with

Ancillary Provisions and Additional Construction Requirements

Figure 3.10.7.4 Diagram a and b; or

- (ii) where a heat shield is installed, in accordance with Figure 3.10.7.4 Diagram a and b.
- (d) The flue must—
 - (i) have been tested and passed the tests required by AS/NZS 2918; and
 - (ii) be installed in accordance with Figure 3.10.7.5; and
 - (iii) terminate in accordance with Figure 3.10.7.2.
- (e) Flue types or installation of flues in areas not specifically covered by Figure 3.10.7.4 Diagram a, b and Figure 3.10.7.5 must be installed in accordance with AS/NZS 2918.

Figure 3.10.7.4 Acceptable location of free standing heating appliances

Diagram a — Elevation

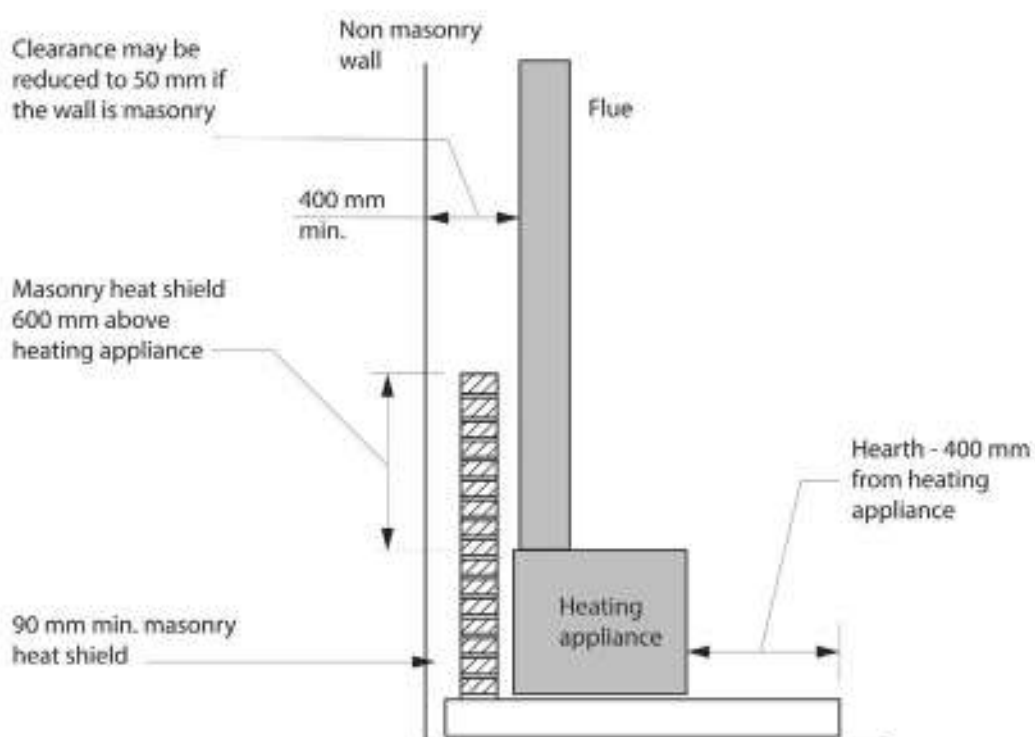

Ancillary Provisions and Additional Construction Requirements

Diagram b — Plan view

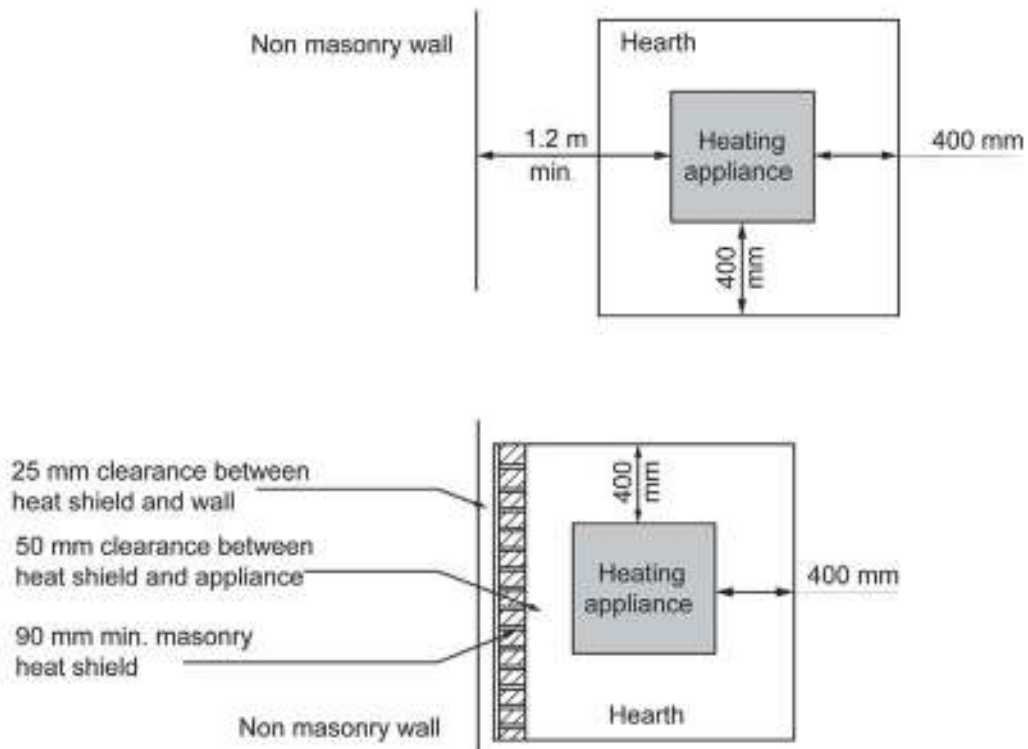

Ancillary Provisions and Additional Construction Requirements

Figure 3.10.7.5 Acceptable flue installation details

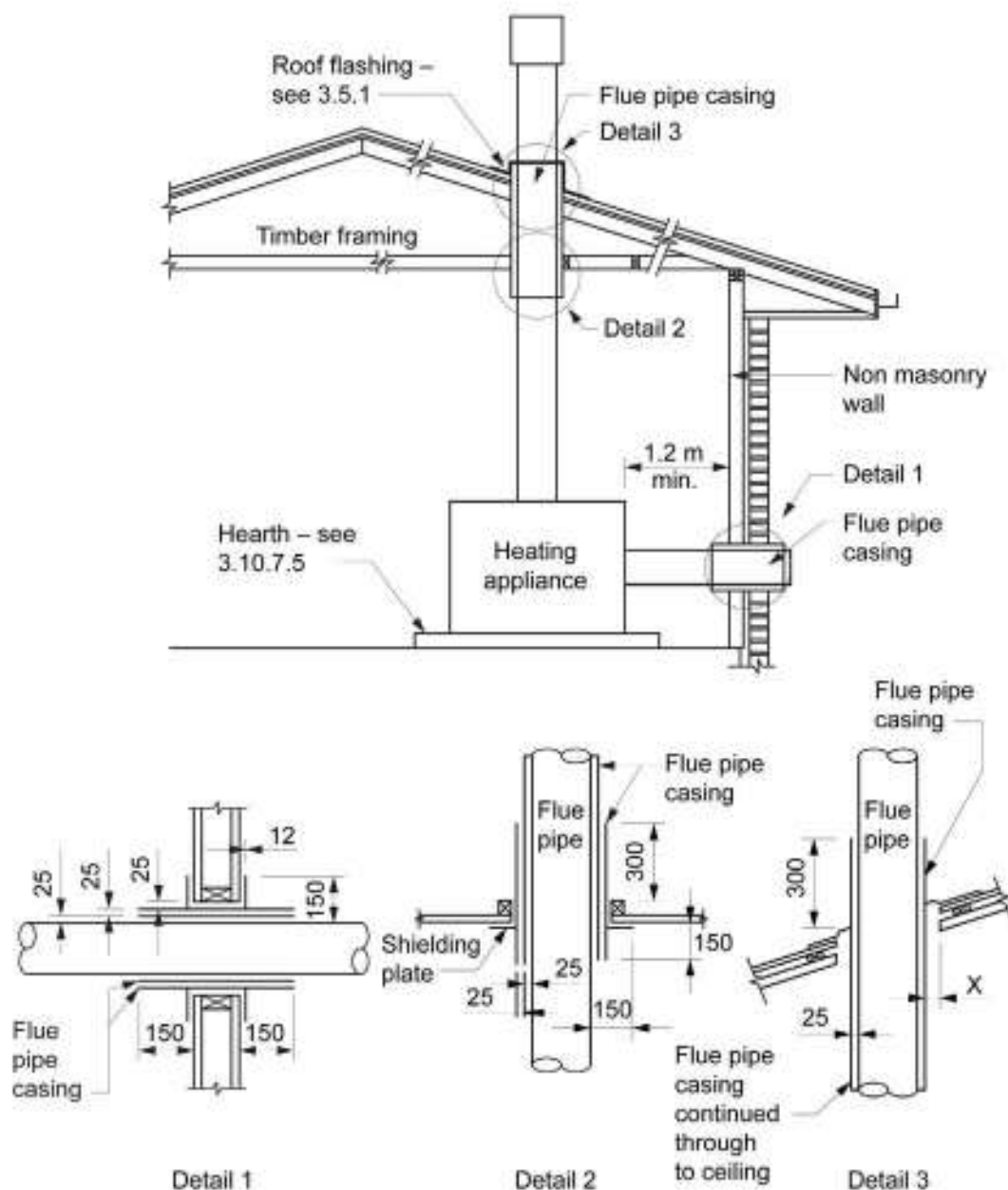

Note to Figure 3.10.7.5: Flue pipe size — 150 mm maximum (for other sizes see AS/NZS 2918).

3.10.7.6 Installation of boilers and pressure vessels

The installation of a boiler or pressure vessel heating appliance within a building, must comply with the following:

- (a) The distance between the vent of any explosion relief device and any adjacent wall, roof, ceiling or other solid construction must be calculated in accordance with Table 3.10.7.1.

Table 3.10.7.1 Minimum clearances for explosion relief

Clearance from	Minimum Clearance (metres)
Adjacent wall or ceiling/roof	$0.4(V/3)^{1/3}$ or 0.4 m, whichever is the greater
Two walls at right angles; or one wall and a ceiling/roof	$0.6(V/3)^{1/3}$ or 0.6 m, whichever is the greater

Ancillary Provisions and Additional Construction Requirements

Note to Table 3.10.7.1: V is the internal volume of the *boiler* or *pressure vessel* being vented, up to the connection of the flue.

- (b) Floor surfaces beneath a *boiler* or *pressure vessel* must be *water resistant* and formed to drain away from supports and structural building elements.
- (c) Where a safe tray is provided to trap liquids, it must be manufactured from a material resistant to corrosion from the contents of the *boiler* or *pressure vessel*.
- (d) Building elements surrounding a *boiler* must be protected from any furnace heat by refractory material or effective air spaces so that—
 - (i) steel elements do not exceed a temperature of more than 300°C; and
 - (ii) concrete elements do not exceed a temperature of more than 200°C; and
 - (iii) timber elements do not exceed a temperature of more than 150°C.

Explanatory information:

The requirements of 3.10.7.6 are limited to a *boiler* or *pressure vessel* heating appliance within a building. Therefore, the provision does not apply to a *boiler* or *pressure vessel* outside of these limitations, such as a portable gas appliance.

Table 3.10.7.1 provides the minimum clearance *required* which is based on the volume of the space being vented. The minimum clearance is determined by a formula which includes the volume of the space being vented.

The intention of the explosion relief provisions is that, in the event of an explosion, the extent of damage is limited.

The minimum clearance determined in the first row is 0.4 m from an adjacent wall or ceiling/roof.

The minimum clearance determined in the second row is 0.6 m from two walls at right angles, or one wall and a ceiling/roof. This scenario poses a higher risk of damage from over pressure experienced during a deflagration and therefore both the ventilation and clearances are increased.

Part **3.11**

Structural Design Manuals

Part 3.11 * * * * *

Part 3.11 Structural Design Manuals

Part 3.11 * * * * *

Part 3.11

* * * * *

The content of [Part 3.11](#), which existed in BCA 2016, has been consolidated into a new [Part 3.0](#). The number [Part 3.11](#) has been retained so as not to change the numbering of the current BCA from that of BCA 2016.

Part **3.12**

Energy Efficiency

- Part 3.12** **Energy efficiency**
- Part 3.12.1** **Building fabric**
- Part 3.12.2** **External glazing**
- Part 3.12.3** **Building sealing**
- Part 3.12.4** **Air movement**
- Part 3.12.5** **Services**

Part 3.12 Energy Efficiency

Part 3.12 Energy efficiency

Acceptable Construction Practice

3.12.0 Application of Part 3.12

3.12.0.1 Heating and cooling loads

Part 3.12.1 Building fabric

3.12.1 Application

Acceptable Construction Practice

3.12.1.1 Building fabric thermal insulation

3.12.1.2 Roofs

3.12.1.3 Roof lights

3.12.1.4 External walls

3.12.1.5 Floors

3.12.1.6 Attached Class 10a buildings

Part 3.12.2 External glazing

3.12.2 Application

Acceptable Construction Practice

3.12.2.1 External glazing

3.12.2.2 Shading

Part 3.12.3 Building sealing

3.12.3 Application

Acceptable Construction Practice

3.12.3.1 Chimneys and flues

3.12.3.2 Roof lights

3.12.3.3 External windows and doors

3.12.3.4 Exhaust fans

3.12.3.5 Construction of ceilings, walls and floors

3.12.3.6 Evaporative coolers

Part 3.12.4 Air movement

3.12.4 Application

Acceptable Construction Practice

3.12.4.1 Air movement

3.12.4.2 Ventilation openings

3.12.4.3 Ceiling fans and evaporative coolers

Part 3.12.5 Services

3.12.5 Application

Acceptable Construction Manual

3.12.5.0 Application

Acceptable Construction Practice

3.12.5.1 Insulation of services

3.12.5.2 Central heating water piping

3.12.5.3 Heating and cooling ductwork

3.12.5.4 Electric resistance space heating

3.12.5.5 Artificial lighting

3.12.5.6 Water heater in a heated water supply system

3.12.5.7 Swimming pool heating and pumping

3.12.5.8 Spa pool heating and pumping

Part 3.12 Energy efficiency

Note:

From 1 May 2019 to 30 April 2020 Part 3.12 of NCC 2016 Volume Two may apply instead of [Part 3.12](#) of NCC 2019. From 1 May 2020 [Part 3.12](#) of NCC 2019 applies.

Appropriate *Performance Requirements*

Where an alternative energy efficiency design is proposed as a *Performance Solution* to that described in [Part 3.12](#), that proposal must comply with—

- (a) [Performance Requirement P2.6.1](#); and
- (b) [Performance Requirement P2.6.2](#); and
- (c) the relevant *Performance Requirements* determined in accordance with [A2.2\(3\)](#) and [A2.4\(3\)](#) as applicable.

State and Territory Variations

1. In New South Wales, [Part 3.12](#) does not apply.

Note: The New South Wales Additions contain energy efficiency measures that apply in New South Wales to support and complement BASIX.

2. In the Northern Territory, [Part 3.12](#) is replaced with BCA 2009 Part 3.12.
3. In South Australia, for the purposes of this Part, a sunroom or the like is deemed to be a Class 10a building and must comply with [3.12.1.6](#).
4. In Queensland, building work for the energy efficiency of Class 1 buildings is also regulated by the Building Act 1975 and the Queensland Development Code MP 4.1—Sustainable buildings.
5. In Tasmania, from 1 May 2019 to 30 April 2020 [Part 3.12](#) of BCA 2016 may apply in lieu of [Part 3.12](#) of BCA 2019. From 1 May 2020 [Part 3.12](#) of BCA 2019 applies.
6. In the Australian Capital Territory, see the [ACT Appendix](#) for further information on application to building work on new buildings and additions to existing buildings in the ACT.

Acceptable Construction Practice

3.12.0 Application of Part 3.12

- (a) [Performance Requirement P2.6.1](#) for the thermal performance of the building is satisfied by—
 - (i) complying with—
 - (A) [3.12.0.1](#), for reducing the heating or cooling loads; and
 - (B) [3.12.1.1](#), for building *fabric* thermal insulation; and
 - (C) [3.12.1.2\(c\)](#) and [3.12.1.4\(d\)](#), for thermal breaks; and
 - (D) [3.12.1.2\(e\)](#), for compensating for a loss of ceiling insulation, other than where the *house energy rating software* used can automatically compensate for a loss of ceiling insulation; and
 - (E) [3.12.1.5\(c\)](#) and [3.12.1.5\(d\)](#), for floor edge insulation; and
 - (F) [Part 3.12.3](#), for building sealing; or
 - (ii) complying with—
 - (A) [Part 3.12.1](#), for the building *fabric*; and
 - (B) [Part 3.12.2](#), for the external *glazing* and shading; and
 - (C) [Part 3.12.3](#), for building sealing; and
 - (D) [Part 3.12.4](#), for air movement.

State and Territory Variations

[3.12.0\(a\)](#) is replaced in Victoria as follows:

Energy Efficiency

(a) *Performance Requirement P2.6.1* for the thermal performance of the building is satisfied by—

- (i) complying with—
 - (A) 3.12.0.1, for reducing the heating or cooling loads; and
 - (B) 3.12.1.1, for building *fabric* thermal insulation; and
 - (C) 3.12.1.2(c) and 3.12.1.4(d), for thermal breaks; and
 - (D) 3.12.1.2(e), for compensating for a loss of ceiling insulation; and
 - (E) 3.12.1.5(c) and 3.12.1.5(d), for floor edge insulation; and
 - (F) Part 3.12.3, for building sealing; and

in the case of a new Class 1 building, having either a rainwater tank connected to all sanitary flushing systems, or a solar water heater system, installed in accordance with the Plumbing Regulations 2018.

- (ii) complying with—
 - (A) Part 3.12.1, for the building *fabric*; and
 - (B) Part 3.12.2, for the external *glazing* and shading; and
 - (C) Part 3.12.3, for building sealing; and
 - (D) Part 3.12.4, for air movement; and

in the case of a new Class 1 building, having either a rainwater tank connected to all sanitary flushing systems, or a solar water heater system, installed in accordance with the Plumbing Regulations 2018; or

(b) *Performance Requirement P2.6.2* for reducing greenhouse gas emissions is satisfied by complying with Part 3.12.5.

Explanatory information:

There are two options for complying with the energy efficiency *Deemed-to-Satisfy Provisions* 3.12.1 to 3.12.4:

Option 1 Energy Rating — 3.12.0(a)(i) to achieve the *required* energy rating and comply with (B) to (F) for energy-saving features such as the testing and installation of insulation, thermal breaks, compensation for downlights other than where the *house energy rating software* used can automatically compensate for a loss of ceiling insulation, floor edge insulation and detailed provisions for building sealing.

Option 2 Elemental Provisions — 3.12.0(a)(ii) to satisfy all the detailed provisions including meeting the *Total R-Values* of roofs, walls and floors, the *glazing* allowances and the air movement requirements. These detailed provisions also include the testing and installation of insulation, thermal breaks, compensation for downlights, floor edge insulation and detailed provisions for building sealing.

3.12.0.1 Heating and cooling loads

(a) A building must achieve an energy rating, including the separate heating and cooling load limits, using *house energy rating software*, of greater than or equal to—

- (i) 6 stars; or
- (ii) for a building in *climate zones* 1 or 2, 5.5 stars if the building has an outdoor living area as described in (c) if the outdoor living area—
 - (A) is fully covered with an impervious roof having a *Total R-Value* greater than or equal to 1.5 (for downward heat flow); or
 - (B) has at least one permanently installed ceiling fan; or
- (iii) for a building in *climate zones* 1 or 2, 5 stars if the building has an outdoor living area as described in (c) if the outdoor living area—
 - (A) is fully covered with an impervious roof having a *Total R-Value* greater than or equal to 1.5 (for downward heat flow); and
 - (B) has at least one permanently installed ceiling fan.

(b) The heating and cooling load limits in (a) are specified in the ABCB Standard for NatHERS Heating and Cooling Load Limits.

Explanatory information:

1. To comply with (a), the modelled energy loads of a building must not exceed three separate load limits, i.e.—

Energy Efficiency

- a. the total load limit corresponding to the applicable star rating; and
 - b. the heating load limit; and
 - c. the cooling load limit.
2. Information about building modelling using [house energy rating software](http://www.nathers.gov.au) is available at www.nathers.gov.au.
 3. The ABCB Standard for NatHERS Heating and Cooling Load Limits can be accessed at www.abcb.gov.au.
 4. To comply with (a)(ii), either insulate the roof of the outdoor living area, or provide a ceiling fan.
 5. To comply with (a)(iii), insulate the roof of the outdoor living area and provide a ceiling fan.
 6. The options for complying with 3.12.0.1(a) are shown in the following flowchart.

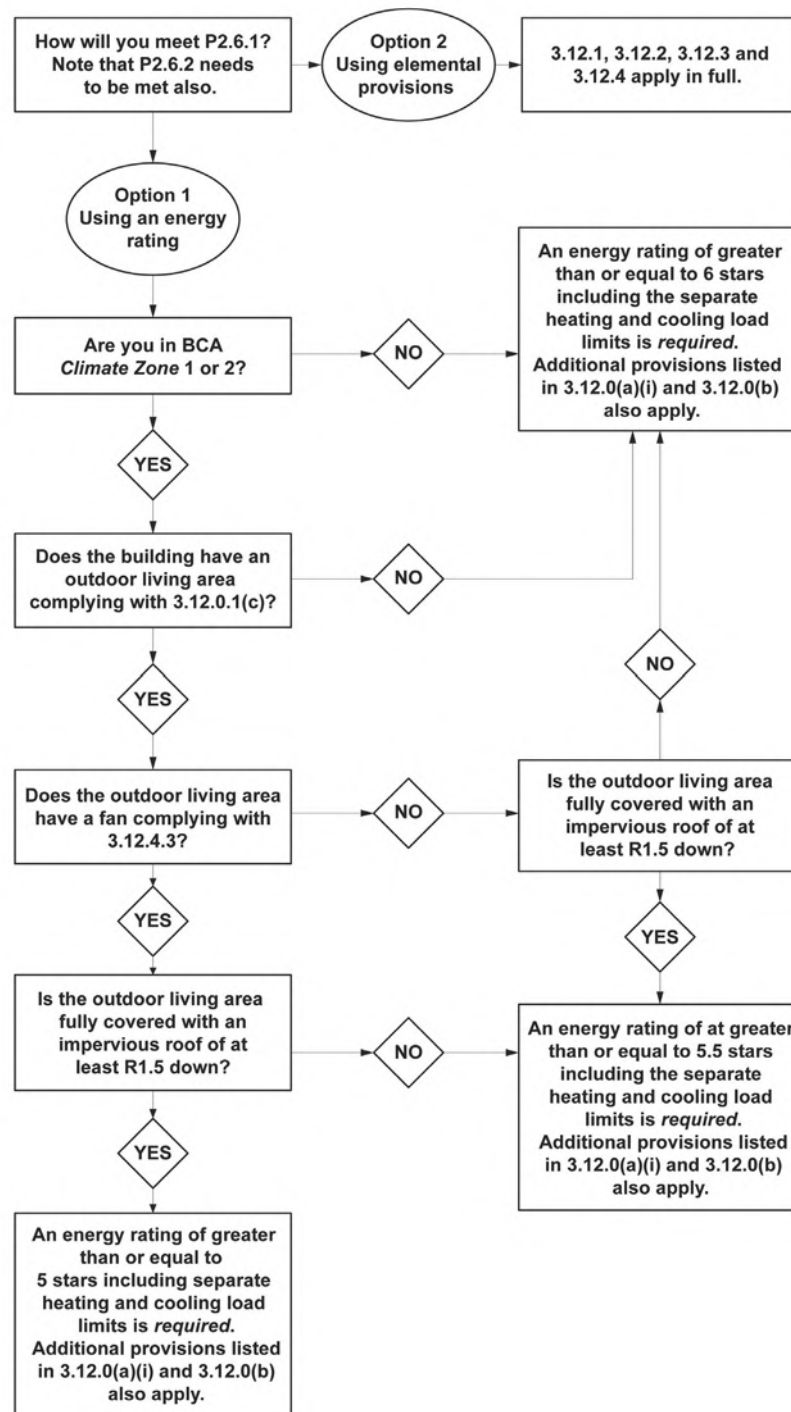

State and Territory Variations

In South Australia after 3.12.0.1(a)(iii), add SA 3.12.0.1(a)(iv) and (v); SA 3.12.0.1(b) and (c); and SA Table 3.12.0.1

Energy Efficiency

as follows:

- (a)
- (iv) for an elevated building with a lightweight flooring system that has a *floor area* up to and including 60 m² – 5 stars; or
 - (v) for an elevated building with a lightweight flooring system that is located in *climate zone* 4, a local government area listed in (c), or an area not within a local government council and it has an on-site *renewable energy* source complying with (b) installed and connected to the building – 5 stars.
- (b) The minimum level of energy to be generated annually by an on-site *renewable energy* source provided in accordance with (a)(v) must be determined by multiplying the *floor area* of the building by the appropriate value in SA Table 3.12.0.1 for the energy rating achieved by the building.

SA Table 3.12.0.1 Required minimum level of energy to be generated by an on-site renewable energy source

Climate Zone	Star rating of Class 1 building 5.0 - 5.4 stars	Star rating of Class 1 building 5.5 - 5.9 stars
4	4.6 kWh/m ²	3.8 kWh/m ²
5	3.9 kWh/m ²	3.4 kWh/m ²
6	8.5 kWh/m ²	7.6 kWh/m ²

(c) The local government areas where (a)(v) applies are—

- Ceduna Council
- Cleve Council
- The Coorong District Council
- Elliston Council
- Flinders Ranges Council
- Franklin Harbour Council
- Goyder Council
- Kangaroo Island Council
- Karoonda East Murray Council
- Kimba Council
- Lower Eyre Peninsula Council
- Mid Murray Council
- Mount Remarkable Council
- Orroroo Carrieton Council
- Peterborough Council
- Southern Mallee Council
- Streaky Bay Council
- Tatiara Council
- Tumby Bay Council
- Wudinna Council

(c) An outdoor living area in (a)(ii) and (a)(iii) is a space that—

- (i) is directly adjoining, and directly accessible from, a general purpose living area of a Class 1 building such as a lounge, kitchen, dining or family room, which is not a room for sleeping or specialist tasks such as a study or home theatre; and
- (ii) has a *floor area* greater than or equal to 12.0 m²; and
- (iii) has length and width dimensions greater than or equal to 2.5 m each; and
- (iv) has an opening height above floor level greater than or equal to 2.1 m; and
- (v) has one side permanently open with a second side either—
 - (A) permanently open; or

Energy Efficiency

(B) readily openable.

- (d) The sides referred to in (c)(v) must be greater than or equal to 900 mm from an allotment boundary or 900 mm from an obstruction to the breeze path such as a building, fence or other structure.

Explanatory information:

1. The opening height in (c)(iv) is to provide a breeze path and is likely to be the measurement from the floor to the underside of a perimeter beam. It is not a ceiling height measurement. It is also not a height for mounting a ceiling fan or the height of ceiling fan blades above the floor. These dimensions need to be determined considering the activities in the space, the safety of occupants of the space and any appropriate safety standards.
2. There is some survey evidence that suggests the majority of home owners turn off their air-conditioners when using an outdoor living area. Another cost effective option is to install a reed switch or other micro switch on the door leading to the outdoor living area in order to automatically deactivate an air-conditioning unit when the door is left open for a period which allows occupants to enter and leave the air-conditioned space but does not affect the operation of the air-conditioner.
3. A side referred to in (c)(v) may contain some obstructions such as columns and barriers. Where an open side is *required* to have a 1 m barrier, consideration as to the type (wire, solid or other) should be made with regard to the overall opening area of the two sides.

- (e) Where a ceiling fan is *required* as part of compliance with (a)(ii) or (a)(iii), the fan must comply with 3.12.4.3.

Part 3.12.1 Building fabric

3.12.1 Application

- (a) The provisions of 3.12.1.1 to 3.12.1.5 apply to—
- (i) a Class 1 building; and
 - (ii) a Class 10a building with a *conditioned space*.
- (b) The provisions of 3.12.1.6 apply to a Class 1 building with an attached Class 10a building.

Acceptable Construction Practice

3.12.1.1 Building fabric thermal insulation

- (a) Where *required*, insulation must comply with AS/NZS 4859.1 and be installed so that it—
- (i) abuts or overlaps adjoining insulation other than at supporting members such as columns, studs, noggings, joists, furring channels and the like where the insulation must butt against the member; and
 - (ii) forms a continuous barrier with ceilings, walls, bulkheads, floors or the like that inherently contribute to the thermal barrier; and

Explanatory information:

1. For example, in a two storey house with the second storey set back, the insulation in the first storey wall, the second storey wall and the roof over the set-back must be continuous. Therefore if the roof over the set-back has insulation on a horizontal ceiling, then insulation is also needed on the vertical in any ceiling space in order to connect the ceiling insulation to the second storey wall.
2. To form a continuous barrier, insulation should be placed in gaps between window and door jambs, heads and sills, and the adjoining wall framing unless a gap is otherwise *required*. This may need to be compressible to allow for movement between members.

- (iii) does not affect the safe or effective operation of a *domestic service* or fitting.

Explanatory information:

Care should be taken when installing insulation to ensure that it does not interfere with the safety or performance of *domestic services* and fittings such as heating flues, recessed light fittings, light transformers, gas appliances and general plumbing and electrical components. This includes providing appropriate clearance as detailed in relevant legislation and referenced standards such as for electrical, gas and fuel oil installations.

- (b) Where *required*, *reflective insulation* must be installed with—
- (i) the necessary airspace, to achieve the required *R-Value* between a reflective side of the *reflective insulation* and a building lining or cladding; and

Explanatory information:

Airspace adjoining reflective insulation

For *reflective insulation* and the adjoining airspace to achieve its tested *R-Value*, the airspace needs to be a certain width. This width varies depending on the particular type of *reflective insulation* and the *R-Value* to be achieved.

- (ii) the *reflective insulation* closely fitted against any penetration, door or *window* opening; and
- (iii) the *reflective insulation* adequately supported by framing members; and
- (iv) each adjoining sheet of roll membrane being—
 - (A) overlapped greater than or equal to 150 mm; or
 - (B) taped together.

Explanatory information:

Adjoining sheets of roll membrane

Energy Efficiency

Where *reflective insulation* also acts as a vapour barrier or sarking, both the minimum overlap and taping may be necessary.

- (c) Where *required*, bulk insulation must be installed so that—
- (i) it maintains its position and thickness, other than where it crosses roof battens, water pipes, electrical cabling or the like; and

Explanatory information:

Compression of bulk insulation

The *R-Value* of bulk insulation is reduced if it is compressed. The allocated space for bulk insulation must therefore allow the insulation to be installed so that it maintains its correct thickness when using the product's stated *R-Value*, otherwise the *R-Value* needs to be reduced to account for any compression. This is particularly relevant to wall and cathedral ceiling framing whose members can only accommodate a limited thickness of insulation. In some instances, larger framing members or thinner insulation material, such as polystyrene boards, may be necessary to ensure that the insulation achieves its *required R-Value*.

- (ii) in a ceiling, where there is no bulk insulation or *reflective insulation* in the *external wall* beneath, it overlaps the *external wall* by greater than or equal to 50 mm.

Explanatory information:

1. The *R-Value* of *reflective insulation* and its adjoining airspace is affected by the width of the airspace between a reflective side of the *reflective insulation* and the building lining or cladding. For further information on *reflective insulation*, refer to the explanatory information accompanying [Figure 3.12.1.1](#).
2. Artificial cooling of buildings in some climates can cause *condensation* to form inside the layers of the building *envelope*. Such *condensation* can cause significant structural or cosmetic damage to the *envelope* before it is detected. Associated mould growth may also create health risks to the occupants. Effective control of *condensation* is a complex issue. In some locations a fully sealed vapour barrier may need to be installed on the more humid, or generally warmer, side of the insulation. Note that [Part 3.8.7](#) contains specific provisions for *condensation*.

3.12.1.2 Roofs

- (a) Subject to (b) and (e), a roof must—
- (i) achieve the *Total R-Value* specified in [Tables 3.12.1.1a to 3.12.1.1g](#) as appropriate, for the direction of heat flow; and
 - (ii) where a pitched roof has a flat ceiling, have greater than or equal to 50% of the added insulation laid on the ceiling.
- (b) In *climate zones* 1, 2, 3, 4 and 5 the *Total R-Value* specified in [Tables 3.12.1.1a to 3.12.1.1g](#) as appropriate, is reduced by 0.5 where—
- (i) the *required* insulation is laid on the ceiling; and
 - (ii) the roof space is ventilated by—
 - (A) gable vents, ridge vents, eave vents, roof vents or the like that—
 - (aa) are evenly distributed to allow an unobstructed flow of air; and
 - (bb) are located to ensure, where practicable, there are no dead airspaces; and
 - (cc) have an aggregate fixed open area of greater than or equal to 1% of the ceiling area; or
 - (B) having—
 - (aa) not less than 2 wind-driven roof ventilators having an aggregate opening area of greater than or equal to 0.14 m²; and
 - (bb) gable vents, ridge vents, eave vents, roof vents or the like that have an aggregate fixed open area of greater than or equal to 0.2% of the ceiling area.

Energy Efficiency

Table 3.12.1.1a Roof—minimum Total R-values (climate zone 1)

Direction of heat flow	Upper surface solar absorptance value	Minimum <i>Total R-Value</i>
Down	≤ 0.4	3.1
Down	> 0.4 but ≤ 0.6	4.1
Down	> 0.6	5.1

Table 3.12.1.1b Roof—minimum Total R-values (climate zone 2—altitude less than 300 m)

Direction of heat flow	Upper surface solar absorptance value	Minimum <i>Total R-Value</i>
Down	≤ 0.4	4.1
Down	> 0.4 but ≤ 0.6	4.6
Down	> 0.6	5.1

Note to Table 3.12.1.1b: Altitude means the height above the Australian Height Datum at the location where the building is to be constructed.

Table 3.12.1.1c Roof—minimum Total R-values (climate zone 2—altitude 300 m or more)

Direction of heat flow	Upper surface solar absorptance value	Minimum <i>Total R-Value</i>
Down and Up	≤ 0.4	4.1
Down and Up	> 0.4 but ≤ 0.6	4.6
Down and Up	> 0.6	5.1

Note to Table 3.12.1.1c: Altitude means the height above the Australian Height Datum at the location where the building is to be constructed.

Table 3.12.1.1d Roof—minimum Total R-values (climate zone 3)

Direction of heat flow	Upper surface solar absorptance value	Minimum <i>Total R-Value</i>
Down and Up	≤ 0.4	4.1
Down and Up	> 0.4 but ≤ 0.6	4.6
Down and Up	> 0.6	5.1

Table 3.12.1.1e Roof—minimum Total R-values (climate zones 4 and 5)

Direction of heat flow	Upper surface solar absorptance value	Minimum <i>Total R-Value</i>
Up	≤ 0.4	4.1
Up	> 0.4 but ≤ 0.6	4.6
Up	> 0.6	5.1

Table 3.12.1.1f Roof—minimum Total R-values (climate zones 6 and 7)

Direction of heat flow	Upper surface solar absorptance value	Minimum <i>Total R-Value</i>
Up	≤ 0.4	4.6
Up	> 0.4 but ≤ 0.6	5.1
Up	> 0.6	5.1

Table 3.12.1.1g Roof—minimum Total R-values (climate zone 8)

Direction of heat flow	Upper surface solar absorptance value	Minimum <i>Total R-Value</i>
Up	≤ 0.4	6.3

Energy Efficiency

Direction of heat flow	Upper surface solar absorptance value	Minimum <i>Total R-Value</i>
Up	> 0.4 but ≤ 0.6	6.3
Up	> 0.6	6.3

Explanatory information:

1. The term 'as appropriate' used in reference to Tables 3.12.1.1a to 3.12.1.1g, means the table used must be appropriate to the *climate zone* in which the building is to be located.
2. The roof space ventilation option, in *climate zones* 1, 2, 3, 4 and 5, applies to a pitched roof with a flat ceiling to ensure that efficient cross ventilation is achieved in the roof space to remove hot air. Roof space ventilation is generally not suitable for most flat, skillion, cathedral ceiling and similar roof types because of the lack of space between the ceiling and roof.
3. Care should be taken to ensure that the roof *ventilation openings* do not allow rain penetration and that they comply with appropriate bushfire provisions.
4. Gaps between roof tiles with sarking (or *reflective insulation* at rafter level) and metal sheet roofing are not acceptable methods of providing roof space ventilation.
5. Compliance with the ventilation provisions in 3.12.1.2(b)(ii) may result in the ingress of wind driven rain, fine dust, corrosive aerosols, or stimulate the growth of mould or fungus in the roof enclosure. Consideration should therefore be given to the surrounding environmental features, including exposure to marine or industrial environments, prior to adopting this as an alternative to the roof insulation provisions in 3.12.1.2(b)(i)(B).
6. A low solar absorptance roof reduces the flow of heat from solar radiation better than a high solar absorptance roof. A roof with a solar absorptance value of less than 0.4 typically corresponds to a roof of light colour such as white, off-white or cream. Typical absorptance values based on ASTM E903 are as follows.

Typical absorptance values

Colour	Value
Slate (dark grey)	0.90
Red, green	0.75
Yellow, buff	0.60
Zinc aluminium — dull	0.55
Galvanised steel — dull	0.55
Light grey	0.45
Off white	0.35
Light cream	0.30

7. The direction of heat flow in Tables 3.12.1.1a to 3.12.1.1g, as appropriate, is considered to be the predominant direction of heat flow for the hours of occupation of the building. It takes into account the higher rate of occupancy of houses at night time rather than day time.
8. The weight of roof or ceiling insulation, particularly if additional ceiling insulation is used for compliance with the energy efficiency provisions, needs to be considered in the selection of plasterboard, plasterboard fixings and building framing.

(c) A roof that—

- (i) is *required* to achieve a minimum *Total R-Value*; and
- (ii) has metal sheet roofing directly fixed to metal purlins, metal rafters or metal battens; and
- (iii) does not have a ceiling lining or has a ceiling lining fixed directly to those metal purlins, metal rafters or metal battens (see Figure 3.12.1.1(b)),

must have a thermal break, consisting of a material with an *R-Value* of greater than or equal to 0.2, installed between the metal sheet roofing and its supporting metal purlins, metal rafters, or metal battens.

(d) A roof, or roof and associated ceiling, is deemed to have the *Total R-Value* in Figure 3.12.1.1.

Figure 3.12.1.1 Total R-Value for typical roof and ceiling construction

3.12.1.1(a) Flat roof, skillion roof and cathedral ceiling with a ceiling lining under rafter

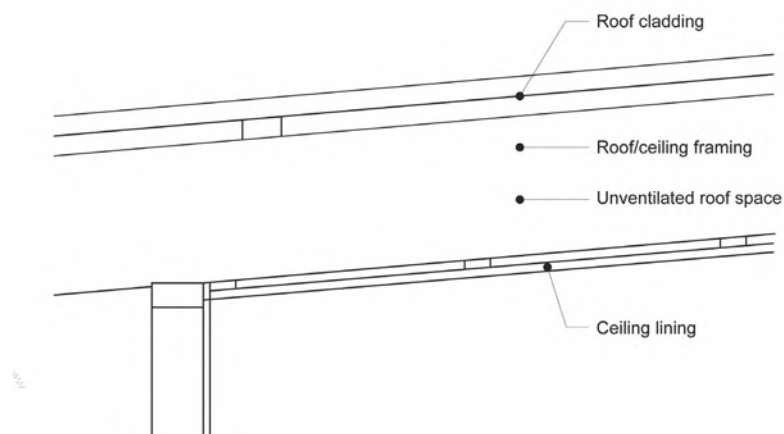

Unventilated with a downwards direction of heat flow — *Total R-Value* of 0.48

Unventilated with an upwards direction of heat flow — *Total R-Value* of 0.36

3.12.1.1(b) Flat roof, skillion roof and cathedral ceiling with exposed rafters

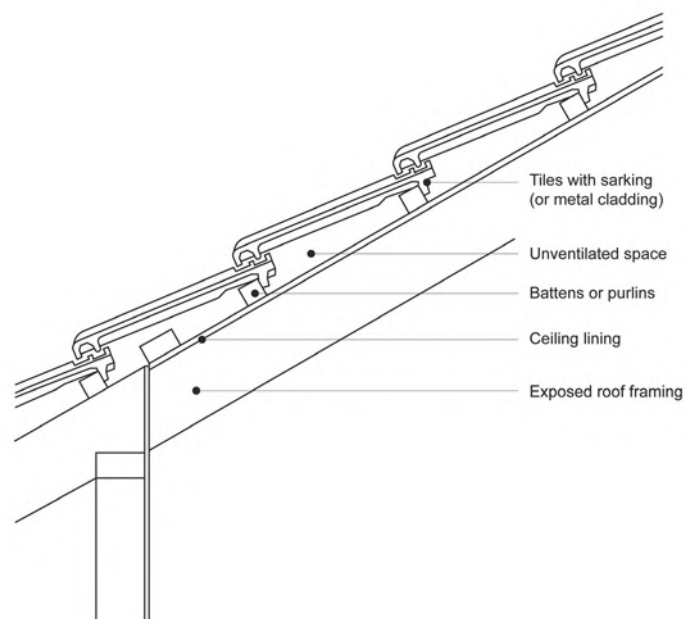

Unventilated with a downwards direction of heat flow — *Total R-Value* of 0.44

Unventilated with an upwards direction of heat flow — *Total R-Value* of 0.38

3.12.1.1(c) Tiled pitched roof with flat ceiling

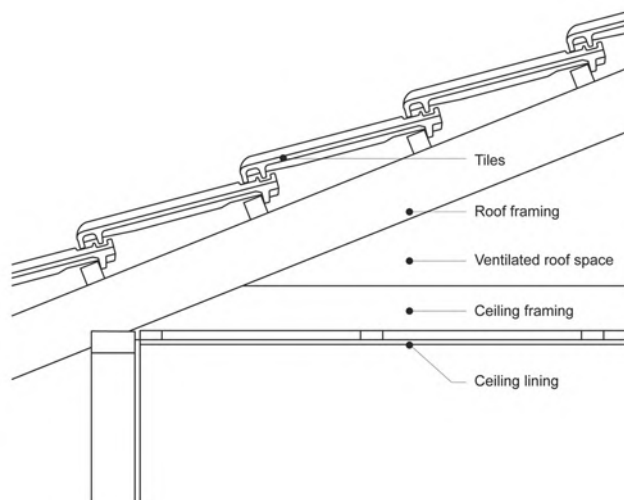

Ventilated with a downwards direction of heat flow — *Total R-Value* of 0.74

Ventilated with an upwards direction of heat flow — *Total R-Value* of 0.23

Unventilated with a downwards direction of heat flow — *Total R-Value* of 0.56

Unventilated with an upwards direction of heat flow — *Total R-Value* of 0.41

3.12.1.1(d) Metal pitched roof with flat ceiling

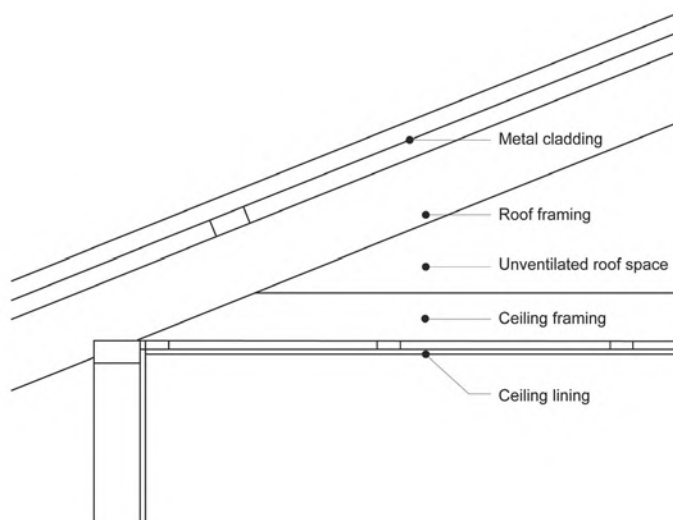

Ventilated with a downwards direction of heat flow — *Total R-Value* of 0.72

Ventilated with an upwards direction of heat flow — *Total R-Value* of 0.21

Unventilated with a downwards direction of heat flow — *Total R-Value* of 0.54

Unventilated with an upwards direction of heat flow — *Total R-Value* of 0.39

Notes to Figure 3.12.1.1:

1. The *Total R-Value* of the roof and ceiling construction in Figure 3.12.1.1 is based on there being a roof space. If the roof space is filled, the roof space *R-Value* needs to be subtracted from the *Total R-Value* of the roof and ceiling materials.
2. The *Total R-Value* of the unventilated roof and ceiling construction in Figure 3.12.1.1(c) for tiled roofs are based on there being *sarking-type material* which would prevent ventilation of the roof space through the gaps in the roof tiles.

Explanatory information:

1. Typical construction:

Figure 3.12.1.1 provides examples of various roof and ceiling construction. The *R-Value* of the *required* insulation is calculated by subtracting the inherent *Total R-Value* of the roof and ceiling construction from the *Total R-Value* in Tables 3.12.1.1a to 3.12.1.1g. The inherent *Total R-Value* of the typical roof and ceiling has been determined by adding together the *R-Values* of the outdoor air film, roof cladding, roof airspace, ceiling sheet lining and internal film.

2. The *Total R-Value* of the roof and ceiling materials may need to be adjusted if other building elements such as sarking are also installed. For example, sarking or sheet insulation under tiles may change a roof space from “ventilated” to “unventilated”.

3. Thermal bridging:

Irrespective of the framing material used, the minimum added *R-Value* specified in Figures 3.12.1.1 and 3.12.1.3 and Table 3.12.1.4 is deemed to include the effect of thermal bridging created by framing members in situations other than described in explanatory note 4.

4. Thermal break:

Because of the high thermal conductance of metal, a thermal break is to be provided where the ceiling lining of a house is fixed directly to the underside of the metal purlins or metal battens of a metal deck roof or where there is no ceiling lining. The purpose of the thermal break is to ensure that the thermal performance of this form of roof construction is comparable to that of a similar roof with timber purlins or timber battens.

A thermal break may be provided by materials such as timber, expanded polystyrene strips, plywood or compressed bulk insulation. The material used as a thermal break must separate the metal purlins or metal battens from the metal deck roofing and achieve the specified *R-Value*. *Reflective insulation* alone is not suitable for use as a thermal break because it requires an adjoining airspace to achieve the specified *R-Value* (see explanatory note 6).

For the purposes of 3.12.1.2(c), expanded polystyrene strips of not less than 12 mm thickness, compressed bulk insulation, and timber of not less than 20 mm thickness are considered to achieve an *R-Value* of not less than 0.2.

5. Location of insulation:

The thermal performance of the roof may vary depending on the position of the insulation, the climatic conditions, the design of the house and the way in which it is operated. For example, insulation installed under the roof, rather than on the ceiling, of a conditioned house with a large roof space is less effective because of the additional volume of roof airspace that would need to be heated or cooled. Conversely, for an unconditioned house, the use of *reflective insulation* is more effective when placed directly under the roof.

6. Choice of insulation:

There are a number of different insulation products that may be used to achieve the minimum added *R-Value*. However, care should be taken to ensure that the choice made is appropriate for the construction and climatic conditions as the location and relationship between options in Figures 3.12.1.1 and 3.12.1.3 and Table 3.12.1.4 may not be suitable in all circumstances for both practical and technical reasons. For instance, in some *climate zones*, insulation should be installed with due consideration of *condensation* and associated interaction with adjoining building materials. As an example, *reflective insulation* or sarking installed on the cold side of the building *envelope* should be vapour permeable. Note that Part 3.8.7 contains specific provisions for *condensation*.

Reflective insulation is considered to provide the following additional *R-Values* when used in conjunction with the *Total R-Value* of a pitched roof and flat ceiling construction described in Figure 3.12.1.1. To achieve these values, the *reflective insulation* must be laid directly under the roof cladding and have a minimum airspace of 15 mm between a reflective side of the *reflective insulation* and the adjoining lining or roof cladding (see 3.12.1.1(b)).

The actual *R-Value* added by *reflective insulation* and its adjoining airspace should be determined for each product in accordance with relevant standards, taking into consideration factors such as the number of adjacent airspaces, dimensions of the adjacent airspace, whether the space is ventilated and the presence of an anti-glare coating. When *reflective insulation* has an anti-glare coating on one side, the emittance value of that side will be greater than the value of the uncoated side.

Also, where another emittance value for *reflective insulation* is used (other than the value used in the table below), care should be taken to ensure that the number of airspaces allowed for is consistent with the form of construction and whether the airspace is reflective, partially reflective or non-reflective. Where bulk insulation fills the airspace, the *Total R-Value* should be reduced to take account of the loss of airspace.

Energy Efficiency

R-Value added by reflective insulation—Pitched roof (>10°) with horizontal ceiling

Emittance of added <i>reflective insulation</i>	Direction of heat flow ^{Note 1}	R-Value added—unventilated roof space	R-Value added—ventilated roof space
0.2 outer / 0.05 inner	Down	1.12	1.21
0.2 outer / 0.05 inner	Up	0.75	0.59
0.9 outer / 0.05 inner	Down	0.92	1.01
0.9 outer / 0.05 inner	Up	0.55	0.40

R-Value added by reflective insulation—Flat skillion or pitched roof (≤10°) with horizontal ceiling

Emittance of added <i>reflective insulation</i>	Direction of heat flow ^{Note 1}	R-Value added
0.2 outer / 0.05 inner	Down	1.28
0.2 outer / 0.05 inner	Up	0.68
0.9 outer / 0.05 inner	Down	1.06
0.9 outer / 0.05 inner	Up	0.49

R-Value added by reflective insulation—Pitched roof with cathedral ceilings

Emittance of added <i>reflective insulation</i>	Direction of heat flow ^{Note 1}	R-Value added — pitch ≥ 15° to ≤ 25°	R-Value added — pitch > 25° to ≤ 35°	R-Value added — pitch > 35° to ≤ 45°
0.2 outer / 0.05 inner	Down	0.96	0.86	0.66
0.2 outer / 0.05 inner	Up	0.72	0.74	0.77
0.9 outer / 0.05 inner	Down	0.74	0.64	0.44
0.9 outer / 0.05 inner	Up	0.51	0.52	0.53

Notes:

- The *required* direction of heat flow applicable in each of the *climate zones* specified in Tables 3.12.1.1a to 3.12.1.1g.
 - Ventilated roof space means ventilated in accordance with 3.12.1.2(b).
- (e) Where, for operational or safety reasons associated with exhaust fans, flues or recessed downlights, the area of *required* ceiling insulation is reduced, the loss of insulation must be compensated for by increasing the *R-Value* of insulation in the remainder of the ceiling in accordance with Table 3.12.1.1h.
- (f) Where the minimum *R-Value* of ceiling insulation *required* to satisfy 3.12.1.2(a) is not stated in Table 3.12.1.1h, interpolation may be used to determine the adjusted minimum *R-Value*.

Table 3.12.1.1h Adjustment of minimum R-Value for loss of ceiling insulation

Percentage of ceiling area uninsulated	Minimum <i>R-Value</i> of ceiling insulation <i>required</i> to satisfy 3.12.1.2(a)										
	1.0	1.5	2.0	2.5	3.0	3.5	4.0	4.5	5.0	5.5	6.0
Adjusted minimum <i>R-Value</i> of ceiling insulation <i>required</i> to compensate for loss of ceiling insulation area											
0.5% to less than 1.0%	1.0	1.6	2.2	2.8	3.4	4.0	4.7	5.4	6.2	6.9	X
1.0% to less than 1.5%	1.1	1.7	2.3	2.9	3.6	4.4	5.2	6.1	7.0	X	X
1.5% to less	1.1	1.7	2.4	3.1	3.9	4.8	5.8	6.8	X	X	X

Energy Efficiency

Percentage of ceiling area uninsulated	Minimum <i>R-Value</i> of ceiling insulation <i>required</i> to satisfy 3.12.1.2(a)											
	1.0	1.5	2.0	2.5	3.0	3.5	4.0	4.5	5.0	5.5	6.0	
	Adjusted minimum <i>R-Value</i> of ceiling insulation <i>required</i> to compensate for loss of ceiling insulation area											
than 2.0%												
2.0% to less than 2.5%	1.1	1.8	2.5	3.3	4.2	5.3	6.5	X	X	X	X	X
2.5% to less than 3.0%	1.2	1.9	2.6	3.6	4.6	5.9	X	X	X	X	X	X
3.0% to less than 4.0%	1.2	2.0	3.0	4.2	5.7	X	X	X	X	X	X	X
4.0% to less than 5.0%	1.3	2.2	3.4	5.0	X	X	X	X	X	X	X	X
5.0% or more	X	X	X	X	X	X	X	X	X	X	X	X

Notes to Table 3.12.1.1h:

- X = not permitted
- Where the minimum *R-Value* of ceiling insulation *required* to satisfy 3.12.1.2(a) is greater than or equal to 6.0, adjustment to compensate for loss of ceiling insulation area is not permitted.

Explanatory information:

- When considering the reduction of insulation because of exhaust fans, flues or recessed downlights, 0.5% of the ceiling area for a 200 m² house would permit 2 bathroom heater-light assemblies, a laundry exhaust fan, a kitchen exhaust fan and either approximately 20 recessed downlights with 50 mm clearance to insulation, 10 recessed downlights with 100 mm clearance to insulation or only 3 recessed downlights with 200 mm clearance to insulation.
- Note that Table 3.12.1.1h refers to the *R-Value* of the insulation located on the ceiling and not the *Total R-Value* required of the roof. The roof has an inherent *R-Value* and there may also be insulation at the roof line.
- Note that 3.12.1.2(e) does not require an increase in ceiling insulation for *roof lights*.
- Placing some of the *required* insulation at the roof level may result in a more practical outcome. Insulation at the roof level is effective in warm climates and significantly moderates the roof space extremes and *condensation* risk in cold climates. Note that Part 3.8.7 contains specific provisions for *condensation*.

3.12.1.3 Roof lights

- Roof lights* (including any associated shaft and diffuser) serving a *habitable room* or an interconnecting space such as a corridor, hallway, stairway or the like must—
 - if the *roof lights* are not *required* for compliance with Part 3.8.4 or —
 - comply with Table 3.12.1.2; and
 - have an aggregate area of not more than 3% of the total *floor area* of the storey served; or
 - if the *roof lights* are *required* for compliance with Part 3.8.4 or Part 3.8.5—
 - have an area not more than 150% of the minimum area *required* by Part 3.8.5; and
 - have transparent and translucent elements, including any imperforate ceiling diffuser with—
 - a *Total System SHGC* of not more than 0.29; and
 - a *Total System U-Value* of not more than 2.9.
- For the purposes of Table 3.12.1.2, the following applies:
 - The *roof light* shaft index is determined by measuring the distance from the centre of the shaft at the roof to the centre of the shaft at the ceiling level and dividing it by the average internal dimension of the shaft opening at the ceiling level (or the diameter for a circular shaft) in the same units of measurement.
 - The *roof light* area index is the total area of *roof lights* serving the room or space as a percentage of the *floor area* of the room or space.
 - The total area of *roof lights* is the combined area for all *roof lights* serving the room or space.

Energy Efficiency

- (iv) The area of a *roof light* is the area of the roof opening that allows light to enter the building.
- (v) The thermal performance of an imperforate ceiling diffuser may be included in the *Total System U-Value* of the *roof light*.
- (c) The total area of *roof lights* serving the room or space as a percentage of the *floor area* of the room or space must not be more than 5% unless allowed by (a)(ii).

Table 3.12.1.2 Roof lights – thermal performance of transparent and translucent elements

<i>Roof light</i> shaft index	<i>Roof light</i> area index ≤ 2%	<i>Roof light</i> area index > 2% to ≤ 3%	<i>Roof light</i> area index > 3% to ≤ 4%	<i>Roof light</i> area index > 4% to ≤ 5%
<0.5	<i>Total System SHGC</i> ≤0.83 <i>Total System U-Value</i> ≤8.5	<i>Total System SHGC</i> ≤0.57 <i>Total System U-Value</i> ≤5.7	<i>Total System SHGC</i> ≤0.43 <i>Total System U-Value</i> ≤4.3	<i>Total System SHGC</i> ≤0.34 <i>Total System U-Value</i> ≤3.4
≥0.5 to <1.0	<i>Total System SHGC</i> ≤0.83 <i>Total System U-Value</i> ≤8.5	<i>Total System SHGC</i> ≤0.72 <i>Total System U-Value</i> ≤5.7	<i>Total System SHGC</i> ≤0.54 <i>Total System U-Value</i> ≤4.3	<i>Total System SHGC</i> ≤0.43 <i>Total System U-Value</i> ≤3.4
≥1.0 to <2.5	<i>Total System SHGC</i> ≤0.83 <i>Total System U-Value</i> ≤8.5	<i>Total System SHGC</i> ≤0.83 <i>Total System U-Value</i> ≤5.7	<i>Total System SHGC</i> ≤0.69 <i>Total System U-Value</i> ≤4.3	<i>Total System SHGC</i> ≤0.55 <i>Total System U-Value</i> ≤3.4
≥2.5	<i>Total System SHGC</i> ≤0.83 <i>Total System U-Value</i> ≤8.5	<i>Total System SHGC</i> ≤0.83 <i>Total System U-Value</i> ≤5.7	<i>Total System SHGC</i> ≤0.83 <i>Total System U-Value</i> ≤4.3	<i>Total System SHGC</i> ≤0.83 <i>Total System U-Value</i> ≤3.4

Explanatory information:

- The *Total System SHGC* and *Total System U-Values* are expressed as Australian Fenestration Rating Council (AFRC) values.
- The *Total System SHGC* and *Total System U-Values* are for a *roof light* with or without a ceiling diffuser. A *roof light* may achieve the *required* performance on its own or in conjunction with a ceiling diffuser.
- The *Total System SHGC* and *Total System U-Values* for some simple types of *roof lights* are shown in the table below. Lower *U-Value* figures represent higher thermal resistance. Lower *SHGC* figures represent less solar heat transmission. The table gives worst case assessments, which can be improved by obtaining generic or custom product assessments from suppliers, manufacturers, industry associations (including their online resources) and from competent assessors.

Worst case whole roof light element performance values without a ceiling diffuser or with a perforated ceiling diffuser

Translucent or transparent element description	Domed panel	Flat, framed panel
Single layer clear	<i>Total System SHGC</i> : 0.80 <i>Total System U-Value</i> : 8.4	<i>Total System SHGC</i> : 0.79 <i>Total System U-Value</i> : 8.0
Single tinted	<i>Total System SHGC</i> : 0.66 <i>Total System U-Value</i> : 8.4	<i>Total System SHGC</i> : 0.63 <i>Total System U-Value</i> : 7.9
Single layer translucent ("opal")	<i>Total System SHGC</i> : 0.57 <i>Total System U-Value</i> : 8.4	<i>Total System SHGC</i> : 0.56 <i>Total System U-Value</i> : 7.9
Double layer clear	<i>Total System SHGC</i> : 0.71 <i>Total System U-Value</i> : 5.4	<i>Total System SHGC</i> : 0.70 <i>Total System U-Value</i> : 4.9

Energy Efficiency

Worst case whole roof light element performance values with an imperforate ceiling diffuser

Translucent or transparent element description	Domed panel	Flat, framed panel
Single layer clear	<i>Total System SHGC</i> : 0.72 <i>Total System U-Value</i> : 4.3	<i>Total System SHGC</i> : 0.71 <i>Total System U-Value</i> : 4.2
Single tinted	<i>Total System SHGC</i> : 0.59 <i>Total System U-Value</i> : 4.3	<i>Total System SHGC</i> : 0.57 <i>Total System U-Value</i> : 4.2
Single layer translucent (“opal”)	<i>Total System SHGC</i> : 0.51 <i>Total System U-Value</i> : 4.3	<i>Total System SHGC</i> : 0.50 <i>Total System U-Value</i> : 4.2
Double layer clear	<i>Total System SHGC</i> : 0.64 <i>Total System U-Value</i> : 3.4	<i>Total System SHGC</i> : 0.63 <i>Total System U-Value</i> : 3.2

3.12.1.4 External walls

- (a) Each part of an *external wall* must satisfy the requirements of —
- (i) (b) for all walls; or
 - (ii) (c) for walls with a surface density greater than or equal to 220 kg/m², except for—
 - (A) opaque non-glazed openings such as doors (including garage doors), vents, penetrations, shutters and the like; and
 - (B) *glazing* unless covered by (c).

Explanatory information:

Surface density is the mass of one vertical square metre of wall.

- (b) Each part of an *external wall* must—
- (i) in *climate zones* 1, 2, 3, 4 and 5—
 - (A) achieve a minimum *Total R-Value* of 2.8; or
 - (B) —
 - (aa) achieve a minimum *Total R-Value* of 2.4; and
 - (bb) shade the *external wall* of the storey with a verandah, balcony, eaves, carport or the like, which projects at a minimum angle of 15 degrees in accordance with [Figure 3.12.1.2](#); or
 - (ii) in *climate zones* 6 and 7, achieve a minimum *Total R-Value* of 2.8; or
 - (iii) in *climate zones* 8, achieve a minimum *Total R-Value* of 3.8.
- (c) Each part of an *external wall* with a wall surface density of greater than or equal to 220 kg/m² must—
- (i) in *climate zones* 1, 2 and 3—
 - (A) for a storey, other than one with a storey above, shade the wall with a verandah, balcony, eaves, carport or the like that projects at a minimum angle of 15 degrees in accordance with [Figure 3.12.1.2](#); and
 - (B) when the *external walls* are not shaded in accordance with (A) and there is another storey above, external *glazing* complies with [3.12.2.1](#) with the applicable value for C_{SHGC} in [Tables 3.12.2.1a](#) to [3.12.2.1c](#) reduced by 20%; and
 - (C) incorporate insulation with an *R-Value* of greater than or equal to 0.5; and
 - (D) on the lowest storey containing *habitable rooms*, have either—
 - (aa) a concrete slab-on-ground floor; or
 - (bb) masonry *internal walls*; or
 - (ii) in *climate zone* 5 (option a)—
 - (A) for a storey, other than one with a storey above, shade the wall with a verandah, balcony, eaves, carport

Energy Efficiency

- or the like that projects at a minimum angle of 15 degrees in accordance with [Figure 3.12.1.2](#); and
- (B) when the *external walls* are not shaded in accordance with (A) and there is another storey above, external *glazing* complies with [3.12.2.1](#) with the applicable value for C_{SHGC} in [Table 3.12.2.1e](#) reduced by 15%; and
 - (C) incorporate insulation with an *R-Value* of greater than or equal to 0.5; and
 - (D) on the lowest storey containing *habitable rooms*, have either—
 - (aa) a concrete slab-on-ground floor; or
 - (bb) masonry *internal walls*; or
- (iii) in *climate zone* 5 (option b)—
- (A) shade the wall with a verandah, balcony, eaves, carport or the like that projects at a minimum angle of 15 degrees in accordance with [Figure 3.12.1.2](#); and
 - (B) have external *glazing* that complies with [3.12.2.1](#) with the applicable value for C_{SHGC} in [Table 3.12.2.1e](#) reduced by 15%; and
 - (C) on the lowest storey containing *habitable rooms*, have either—
 - (aa) a concrete slab-on-ground floor; or
 - (bb) masonry *internal walls*; or
- (iv) in *climate zones* 4 and 6 (option a)—
- (A) have external *glazing* that complies with [3.12.2.1](#) with the applicable value for C_U in [Tables 3.12.2.1d](#) and [3.12.2.1f](#) reduced by 15%; and
 - (B) incorporate insulation with an *R-Value* of greater than or equal to 0.5; and
 - (C) on the lowest storey containing *habitable rooms*, have either—
 - (aa) a concrete slab-on-ground floor; or
 - (bb) masonry *internal walls*; or
- (v) in *climate zones* 4 and 6 (option b), have external *glazing* that complies with [3.12.2.1](#) with the applicable value for C_U in [Tables 3.12.2.1d](#) and [3.12.2.1f](#) reduced by 20%; or
- (vi) in *climate zones* 4 and 6 (option c)—
- (A) incorporate insulation with an *R-Value* of greater than or equal to 1.0; and
 - (B) on the lowest storey containing *habitable rooms*, have either—
 - (aa) a concrete slab-on-ground floor; or
 - (bb) masonry *internal walls*; or
- (vii) in *climate zone* 7 (option a)—
- (A) have external *glazing* that complies with [3.12.2.1](#) with the applicable value for C_U in [Table 3.12.2.1g](#) reduced by 15%; and
 - (B) incorporate insulation with an *R-Value* of greater than or equal to 1.0; or
- (viii) in *climate zone* 7 (option b)—
- (A) have external *glazing* that complies with [3.12.2.1](#) with the applicable value for C_U in [Table 3.12.2.1g](#) reduced by 20%; and
 - (B) incorporate insulation with an *R-Value* of greater than or equal to 0.5; or
- (ix) in *climate zone* 7 (option c), incorporate insulation with an *R-Value* of greater than or equal to 1.5; or
- (x) in *climate zone* 8, achieve a minimum *Total R-Value* of 3.8.

Figure 3.12.1.2 Measurement of a projection for wall shading

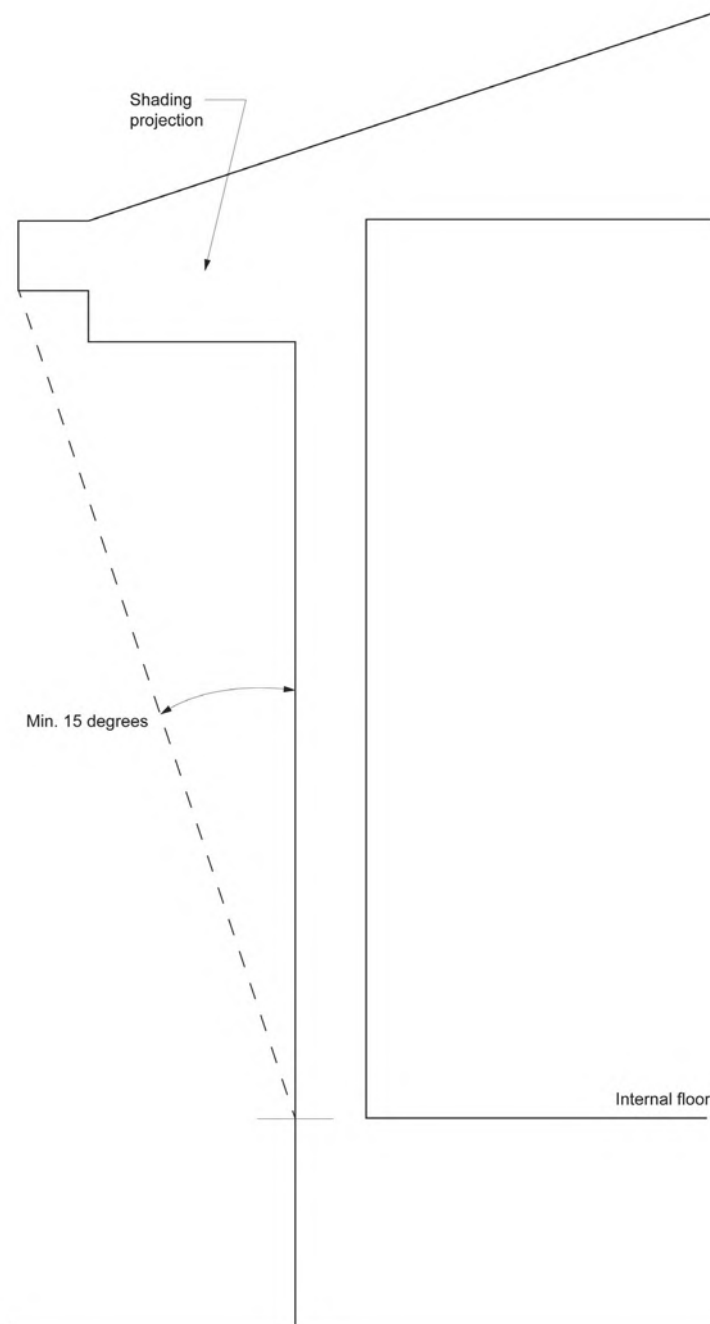
**Explanatory information:**

Guttering can be considered as providing shading if attached to a shading projection.

- (d) A wall in (b) that—
- (i) has lightweight external cladding such as weatherboards, fibre-cement or metal sheeting fixed to the metal frame; and
 - (ii) does not have a wall lining or has a wall lining that is fixed directly to the metal frame (see Figure 3.12.1.3(a) and (b)),
- must have a thermal break, consisting of a material with an *R-Value* greater than or equal to 0.2, installed between the external cladding and the metal frame.

Explanatory information:

1. The thermal performance of metal and timber-framed walls is affected by conductive thermal bridging by the

framing members and convective thermal bridging at gaps between the framing and any added bulk insulation. Metal framed walls are more prone to conductive thermal bridging than timber-framed walls.

2. Because of the high thermal conductance of metal, a thermal break is needed when a metal framing member directly connects the external cladding to the internal lining or the internal environment. The purpose of the thermal break is to ensure that the thermal performance of the metal framed wall is comparable to that of a similarly clad timber-framed wall.

A thermal break may be provided by materials such as timber battens, plastic strips or polystyrene insulation sheeting. The material used as a thermal break must separate the metal frame from the cladding and achieve the specified *R-Value*.

For the purposes of 3.12.1.4(d)(ii), expanded polystyrene strips greater than or equal to 12 mm thickness and timber greater than or equal to 20 mm thickness are deemed to achieve an *R-Value* greater than or equal to 0.2.

The *R-Value* of the thermal break is not included when calculating the *Total R-Value* of the wall, if the thermal break is only applied to the metal frame, because this calculation is done for locations free of framing members.

- (e) A wall constructed in accordance with Figure 3.12.1.3 is deemed to have the *Total R-Value* specified in that Figure.

Figure 3.12.1.3 Total R-Value for typical wall construction

3.12.1.3(a) Weatherboard external wall construction — *Total R-Value* of 0.48

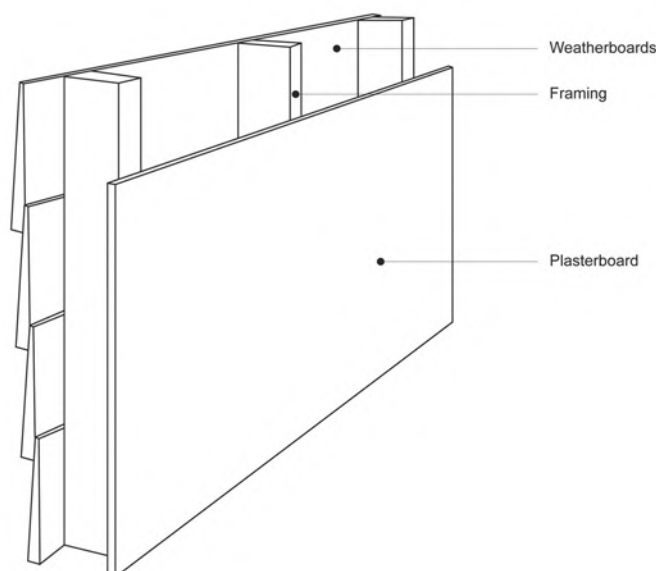

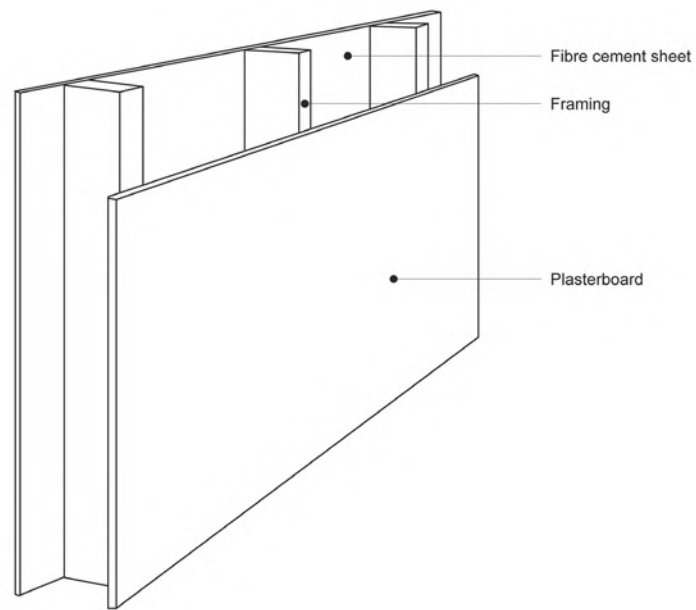
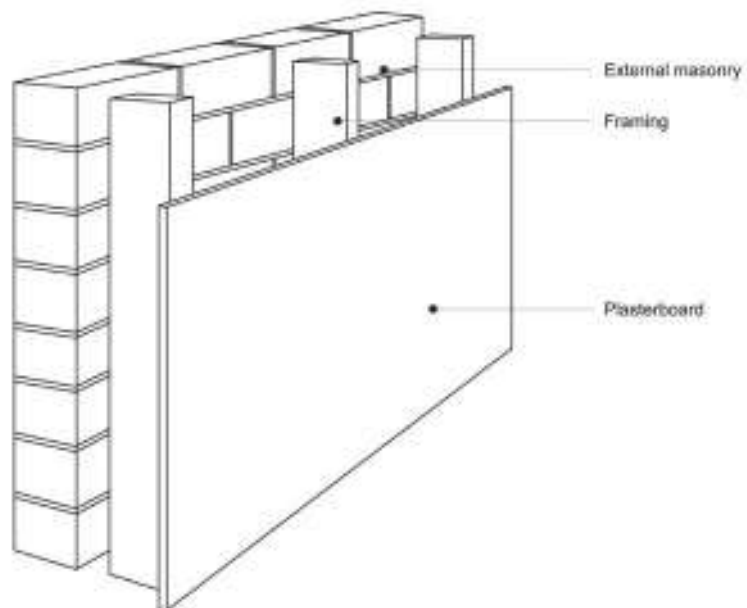
3.12.1.3(b) Fibre-cement sheet *external wall* construction — *Total R-Value* of 0.423.12.1.3(c) Clay masonry veneer *external wall* construction — *Total R-Value* of 0.56

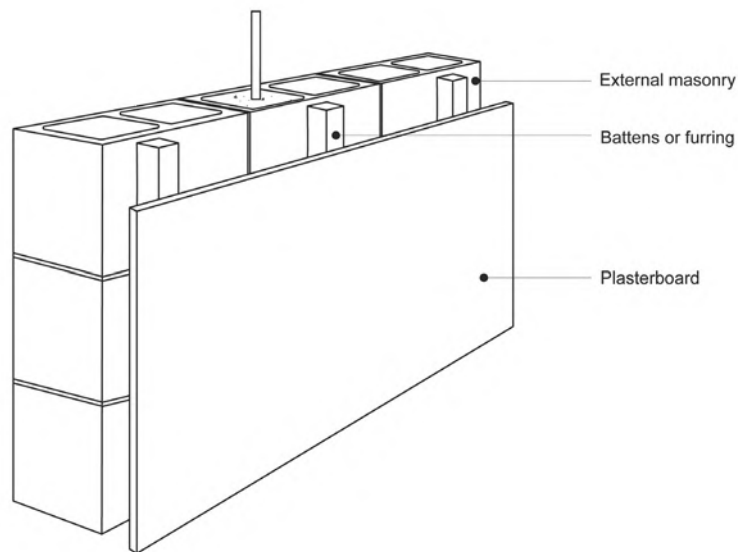
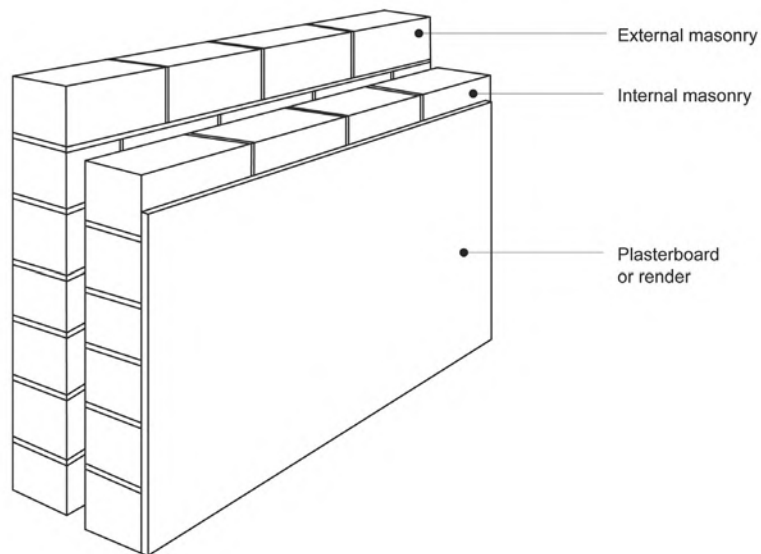
3.12.1.3(d) — Concrete blockwork masonry *external wall* construction — *Total R-Value* of 0.543.12.1.3(e) Cavity clay masonry *external wall* construction — *Total R-Value* of 0.69

Energy Efficiency

3.12.1.3(f) Externally insulated clay masonry (reverse clay masonry veneer) *external wall* construction — *Total R-Value* of 0.53

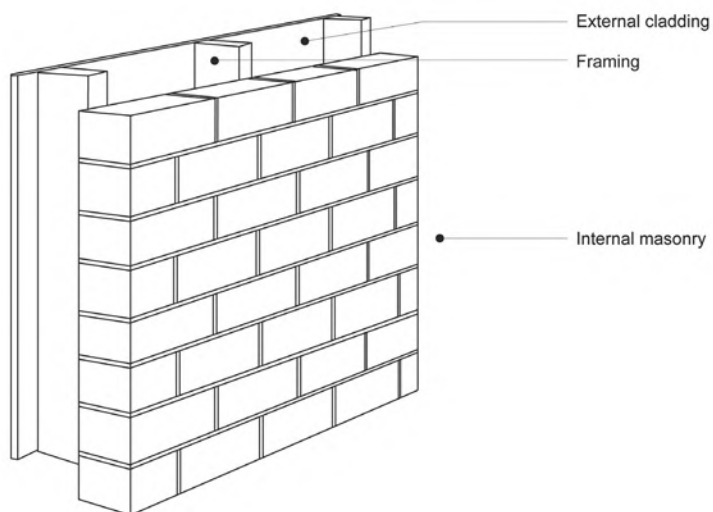

3.12.1.3(g) Externally insulated concrete masonry *external wall* construction — *Total R-Value* of 0.46

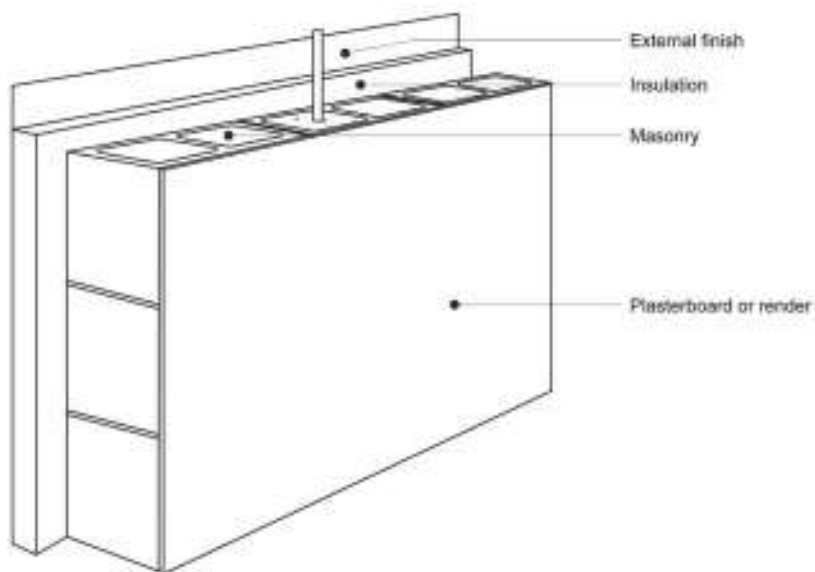

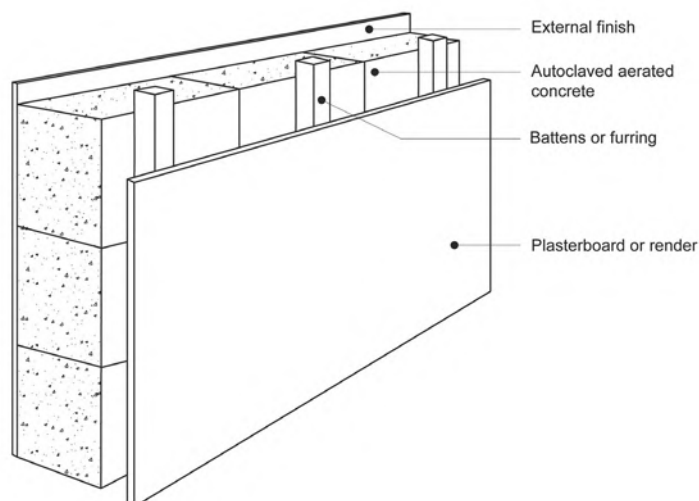
3.12.1.3(h) Autoclaved aerated concrete masonry *external wall* construction — *Total R-Value* of 2.42**Explanatory information:**

- Figure 3.12.1.3 provides examples of typical types of wall construction. The additional *R-Value required* can be calculated by subtracting the inherent *Total R-Value* of the typical wall construction in Figure 3.12.1.3 from the *required Total R-Value*. The inherent *Total R-Value* of the typical wall construction has been arrived at by adding together the *R-Values* for outdoor air film, wall cladding or veneer, wall *cavity* or airspace, internal lining and internal air film. Where a *cavity* or airspace is filled the *Total R-Value* should be reduced by 0.17 to take account for the loss of the *cavity* or airspace.
- Reflective insulation* with one reflective surface having an emittance and direction as indicated, is considered to achieve the following *R-Values* when used in conjunction with the *Total R-Value* of a wall construction, as described in Figure 3.12.1.3. The actual *R-Value* added by *reflective insulation* should be determined for each product in accordance with the standard prescribed in 3.12.1.1(a), which takes into consideration factors such as the number of adjacent airspaces, dimensions of the adjacent airspace, whether the airspace is ventilated and the presence of an anti-glare coating.

Explanatory information for *R-Value* added by *reflective insulation*

Wall construction	Reflective airspace details	<i>R-Value</i> added by <i>reflective insulation</i>
Concrete or masonry with internal plasterboard on battens	One 20 mm reflective airspace located between <i>reflective insulation</i> (of not more than 0.05 emittance inwards) and plasterboard	0.48
<i>External wall</i> cladding (70 mm timber frame with internal lining)	One 70 mm reflective airspace located between <i>reflective insulation</i> (of not more than 0.05 emittance inwards) and plasterboard	0.43
Masonry veneer (70 mm timber frame with internal lining)	(a) One 70 mm reflective airspace located between <i>reflective insulation</i> and plasterboard; and (b) One 25 mm anti-glare airspace located between <i>reflective insulation</i> (of not more than 0.2 emittance outwards) and masonry	0.95

Energy Efficiency

Wall construction	Reflective airspace details	R-Value added by <i>reflective insulation</i>
<i>Cavity</i> masonry	(a) No airspace between the <i>reflective insulation</i> and the inner leaf of masonry; and (b) One 35 mm anti-glare airspace located between <i>reflective insulation</i> (of not more than 0.2 emittance outwards) and the outer leaf of masonry	0.50

3. For further information on *reflective insulation*, refer to the explanatory information following [Figure 3.12.1.1](#).
4. Walls with a surface density of 220 kg/m² or more are deemed to achieve acceptable levels of thermal performance in certain *climate zones* due to their ability to store heat and therefore slow the heat transfer through the building *fabric*. These walls are defined by surface density (kg/m²), which is the mass of one vertical square metre of wall, in order to reduce the complexity when measuring the mass of walls with voids.

The following are examples of some typical wall constructions that achieve a surface density of 220 kg/m²:

- a. Two leaves each of 90 mm thick or greater clay or concrete masonry.
- b. 140 mm thick or greater dense-weight hollow concrete or clay blocks with—
 - i. 10 mm plasterboard or render; and
 - ii. at least one concrete grouted horizontal bond beam; and
 - iii. vertical cores filled with concrete grout at centres not exceeding 1000 mm.
- c. 140 mm thick or greater concrete wall panels and dense-weight hollow concrete or clay blocks with all vertical cores filled with concrete grout.
- d. 190 mm thick or greater dense-weight hollow concrete or clay blocks with—
 - i. at least one concrete grouted horizontal bond beam; and
 - ii. vertical cores filled with concrete grout at centres not exceeding 1800 mm.
- e. Earth-wall construction with a minimum wall thickness of 200 mm.

3.12.1.5 Floors

- (a) A suspended floor, other than an intermediate floor in a building with more than one storey—
 - (i) must achieve the *Total R-Value* specified in [Table 3.12.1.4](#); and

Table 3.12.1.4 Suspended floor – minimum Total R-Value

<i>Climate zone</i>	Direction of heat flow	Minimum <i>Total R-Value</i>
1	Up	1.5
2	Up	1.0
3	Up	1.5
4	Down	2.25
5	Down	1.0
6	Down	2.25
7	Down	2.75
8	Down	3.25

Note to Table 3.12.1.4: For an enclosed perimeter treatment, the underfloor airspace and its enclosure may be included in the *Total R-Value* calculation.

- (ii) with an in-slab or in-screed heating or cooling system, must be insulated—
 - (A) around the vertical edge of its perimeter with insulation having an *R-Value* greater than or equal to 1.0; and
 - (B) underneath the slab with insulation having an *R-Value* greater than or equal to 2.0 which may include insulation installed to meet the requirements of (i); and

Energy Efficiency

- (iii) that is enclosed beneath, must have a barrier installed at or below floor level to prevent convection within the wall *cavity*, from the airspace under the floor.

Explanatory information:

1. An enclosed perimeter treatment means that the airspace under the floor is enclosed between ground and floor level by walls which have only the required subfloor vents.
2. The barrier required by 3.12.1.5(a)(iii) could be an imperforate flashing.
3. Specific solutions for concrete slab and timber floors can be found in documents and online resources prepared by industry associations and product suppliers.

- (b) A floor is deemed to have the *Total R-Value* specified in Tables 3.12.1.5a and 3.12.1.5b.

Table 3.12.1.5a Total R-Value for typical suspended timber floor

Enclosure and height of floor and direction of heat flow	<i>Cavity</i> masonry	190 mm concrete masonry	Single skin masonry	9 mm fibre-cement sheet
Enclosed ≤0.6 m high with an upwards heat flow	<i>Total R-Value</i> : 1.00	<i>Total R-Value</i> : 0.93	<i>Total R-Value</i> : 0.88	<i>Total R-Value</i> : 0.77
Enclosed ≤0.6 m high with a downwards heat flow	<i>Total R-Value</i> : 1.11	<i>Total R-Value</i> : 1.06	<i>Total R-Value</i> : 1.01	<i>Total R-Value</i> : 0.90
Enclosed >0.6 m but to ≤1.2 m high with an upwards heat flow	<i>Total R-Value</i> : 0.86	<i>Total R-Value</i> : 0.81	<i>Total R-Value</i> : 0.76	<i>Total R-Value</i> : 0.65
Enclosed >0.6 m but to ≤1.2 m high with a downwards heat flow	<i>Total R-Value</i> : 1.00	<i>Total R-Value</i> : 0.94	<i>Total R-Value</i> : 0.89	<i>Total R-Value</i> : 0.77
Enclosed >1.2 m to ≤2.4 m high with an upwards heat flow	<i>Total R-Value</i> : 0.76	<i>Total R-Value</i> : 0.72	<i>Total R-Value</i> : 0.67	<i>Total R-Value</i> : 0.57
Enclosed >1.2 m to ≤2.4 m high with a downwards heat flow	<i>Total R-Value</i> : 0.89	<i>Total R-Value</i> : 0.84	<i>Total R-Value</i> : 0.79	<i>Total R-Value</i> : 0.69
Unenclosed with an upwards heat flow	<i>Total R-Value</i> : 0.39	<i>Total R-Value</i> : 0.39	<i>Total R-Value</i> : 0.39	<i>Total R-Value</i> : 0.39
Unenclosed with a downwards heat flow	<i>Total R-Value</i> : 0.51	<i>Total R-Value</i> : 0.51	<i>Total R-Value</i> : 0.51	<i>Total R-Value</i> : 0.51

Notes to Tables 3.12.1.5a:

1. The height of the floor is measured from ground surface to the underside of the floor or the insulation.
2. For the purposes of calculating the *Total R-Value* of a floor, the *R-Value* attributable to an in-slab or in-screed heating or cooling system is ignored.

Table 3.12.1.5b Total R-Value for typical suspended concrete floor

Enclosure and height of floor and direction of heat flow	<i>Cavity</i> masonry	190 mm concrete masonry	Single skin masonry	9 mm fibre-cement sheet
Enclosed ≤0.6 m high with an upwards heat flow	<i>Total R-Value</i> : 0.93	<i>Total R-Value</i> : 0.88	<i>Total R-Value</i> : 0.83	<i>Total R-Value</i> : 0.72
Enclosed ≤0.6 m high with an downwards heat flow	<i>Total R-Value</i> : 1.06	<i>Total R-Value</i> : 1.01	<i>Total R-Value</i> : 0.96	<i>Total R-Value</i> : 0.85
Enclosed >0.6 m but to ≤1.2 m high with an	<i>Total R-Value</i> : 0.81	<i>Total R-Value</i> : 0.76	<i>Total R-Value</i> : 0.71	<i>Total R-Value</i> : 0.60

Energy Efficiency

Enclosure and height of floor and direction of heat flow	Cavity masonry	190 mm concrete masonry	Single skin masonry	9 mm fibre-cement sheet
upwards heat flow				
Enclosed >0.6 m but to ≤1.2 m high with a downwards heat flow	<i>Total R-Value</i> : 0.94	<i>Total R-Value</i> : 0.89	<i>Total R-Value</i> : 0.84	<i>Total R-Value</i> : 0.72
Enclosed >1.2 m to ≤2.4 m high with an upwards heat flow	<i>Total R-Value</i> : 0.71	<i>Total R-Value</i> : 0.67	<i>Total R-Value</i> : 0.62	<i>Total R-Value</i> : 0.52
Enclosed >1.2 m to ≤2.4 m high with a downwards heat flow	<i>Total R-Value</i> : 0.84	<i>Total R-Value</i> : 0.79	<i>Total R-Value</i> : 0.74	<i>Total R-Value</i> : 0.64
Unenclosed with an upwards heat flow	<i>Total R-Value</i> : 0.34	<i>Total R-Value</i> : 0.34	<i>Total R-Value</i> : 0.34	<i>Total R-Value</i> : 0.34
Unenclosed with a downwards heat flow	<i>Total R-Value</i> : 0.46	<i>Total R-Value</i> : 0.46	<i>Total R-Value</i> : 0.46	<i>Total R-Value</i> : 0.46

Notes to Tables 3.12.1.5b:

1. The height of the floor is measured from ground surface to the underside of the floor or the insulation.
2. For the purposes of calculating the *Total R-Value* of a floor, the *R-Value* attributable to an in-slab or in-screed heating or cooling system is ignored.

Explanatory information:

1. Tables 3.12.1.5a and 3.12.1.5b provide examples of the inherent *Total R-Values* of enclosed and unenclosed suspended floors of two typical types of construction. Any added *R-Value* can be calculated by subtracting the inherent *R-Value* of the typical construction in Tables 3.12.1.5a and 3.12.1.5b from the required *Total R-Value* in Table 3.12.1.4.
2. Any non-reflective building membrane fixed between or under floor joists is considered to add an *R-Value* of 0.2 to the *Total R-Value* of the base construction described in Tables 3.12.1.5a and 3.12.1.5b. *Reflective insulation* will achieve a higher value which will need to be determined for each product in accordance with relevant standards. Typically, a reflective building membrane attached beneath the floor joists of an unenclosed floor, with a single bright side facing upwards to a 90 mm airspace, can add an *R-Value* of 0.43 for heat flow upwards and 1.32 for heat flow downwards. Double sided *reflective insulation* with a 90 mm airspace installed under an enclosed floor can add an *R-Value* of 0.55 for heat flow upwards and 1.97 for heat flow downwards. Both examples allow for dust on the upper surface.
3. A reflective or non-reflective building membrane should be installed with due consideration of potentially damaging *condensation* in some *climate zones* and associated interaction with adjoining building materials.
4. For further information on *reflective insulation*, refer to the explanatory information accompanying Figure 3.12.1.1.

- (c) A concrete slab-on-ground—
- (i) with an in-slab or in-screed heating or cooling system, must have insulation with an *R-Value* greater than or equal to 1.0, installed around the vertical edge of its perimeter; and
 - (ii) when in *climate zone* 8, must be insulated—
 - (A) around the vertical edge of its perimeter with insulation having an *R-Value* greater than or equal to 1.0; and
 - (B) underneath the slab with insulation having an *R-Value* greater than or equal to 2.0.
- (d) Insulation *required* by (c)(i) and (c)(ii)(A) must—
- (i) be water resistant; and
 - (ii) be continuous from the adjacent finished ground level—
 - (A) to a depth of greater than or equal to 300 mm; or
 - (B) for at least the full depth of the vertical edge of the concrete slab-on-ground (see Figure 3.12.1.4).
- (e) The requirements of (a)(ii), and (c)(i) do not apply to an in-screed heating or cooling system used solely in a bathroom,

amenity area or the like.

Explanatory information:

3.12.1.5(e) provides an exemption for an in-slab heating or cooling system used solely in bathrooms, amenity areas and the like, as these are typically small areas.

Figure 3.12.1.4 Insulation of slab edge

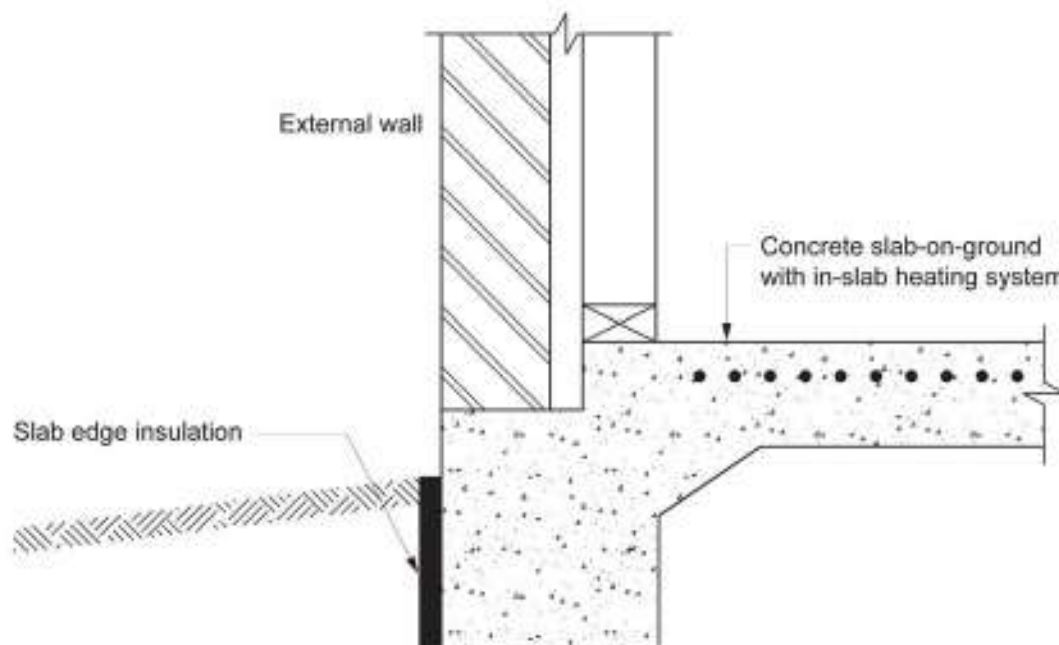

Explanatory information:

Care should be taken to ensure that the type of termite management system selected is compatible with the slab edge insulation.

3.12.1.6 Attached Class 10a buildings

A Class 10a building attached to a Class 1 building must—

- (a) have an external *fabric* that achieves the *required* level of thermal performance for a Class 1 building; or
- (b) be separated from the Class 1 building with construction having the *required* level of thermal performance for the Class 1 building; or
- (c) in *climate zone* 5—
 - (i) be enclosed with masonry walls other than where there are doors and *glazing*; and
 - (ii) be separated from the Class 1 building with a masonry wall that extends to the ceiling or roof; and
 - (iii) achieve a *Total R-Value* in the roof equivalent to that *required* by Tables 3.12.1.1a to 3.12.2.1h as appropriate for the Class 1 building; and
 - (iv) not have a garage door facing the east or west orientation other than if the Class 1 building *glazing* complies with 3.12.2.1 with the applicable value for C_{SHGC} in Tables 3.12.2.1a to 3.12.2.1h as appropriate reduced by 15%.

Explanatory information:

The attachment of a Class 10a building, such as a garage, glasshouse, solarium, pool enclosure or the like should not compromise the thermal performance of the Class 1 building. In addition, the Class 10a building may be insulated and so assist the Class 1 building achieve the *required* thermal performance.

The following are examples of a Class 1 building with an attached Class 10a garage.

Energy Efficiency

In (a), the thermal performance *required* for the Class 1 building may be achieved by including the walls and floor of the Class 1 building that adjoin the Class 10a garage.

In (b), the thermal performance *required* for the Class 1 building may be achieved by including the outside walls and floor of the Class 10a garage.

In (c), in *climate zone* 5, the thermal performance of the Class 1 building may be achieved by ensuring that the roof of the Class 10a building satisfies [Tables 3.12.1.1a to 3.12.1.1g](#) and the walls are of masonry construction.

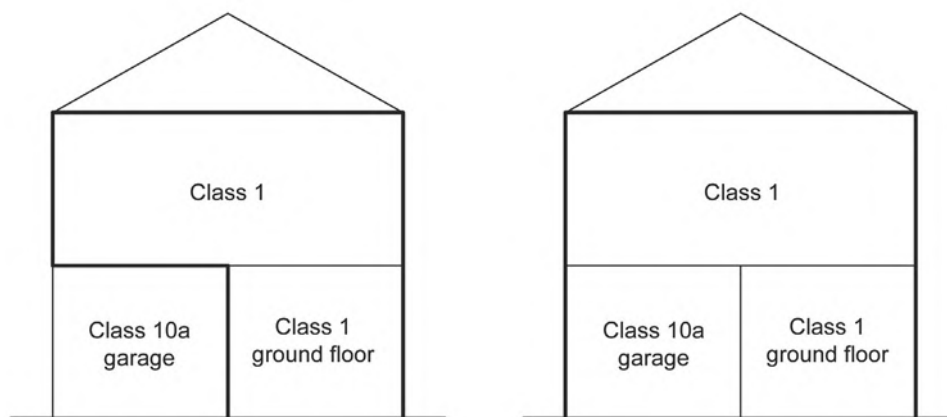

OPTION (a) – Elevation

OPTION (b) – Elevation

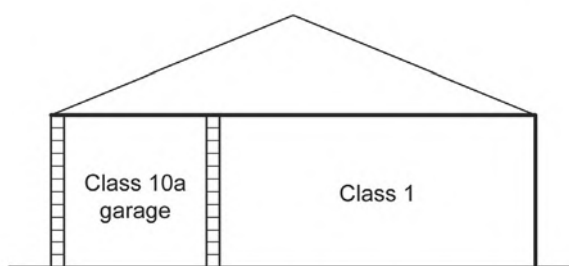

OPTION (c)(i) – Elevation

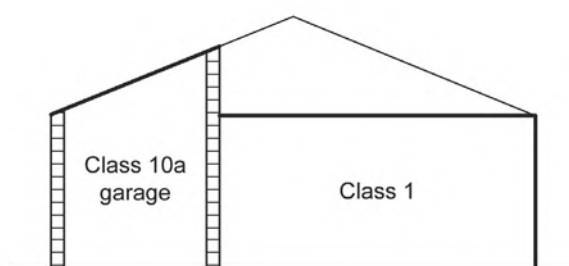

OPTION (c)(ii) – Elevation

Part 3.12.2 External glazing

3.12.2 Application

This Part applies to—

- (a) a Class 1 building; and
- (b) a Class 10a building with a *conditioned space*.

Acceptable Construction Practice

3.12.2.1 External glazing

- (a) The aggregate conductance of the *glazing* in each storey, including any mezzanine, of a building must—
 - (i) not exceed the allowances resulting from—
 - (A) in *climate zone* 1, multiplying the area of the storey, including any mezzanine, measured within the enclosing walls, by the constant C_U obtained from [Table 3.12.2.1a](#); and
 - (B) in *climate zones* 2 to 8, using the constant C_U obtained from [Tables 3.12.2.1b](#) to [3.12.2.1h](#), as appropriate; and
 - (ii) be calculated in accordance with the following calculation—

- (A) in *climate zone* 1—

$$(A_1 \times U_1) + (A_2 \times U_2) + (A_3 \times U_3) + \dots$$

where—

- $A_{1, 2, \text{etc}}$ = the area of each *glazing* element; and
- $U_{1, 2, \text{etc}}$ = the *Total System U-Value* of each *glazing* element; and

- (B) in *climate zones* 2 to 8—

$$[(A_1 \times U_1) + (A_2 \times U_2) + \dots] / [(A_1 \times SHGC_1 \times E_{W1}) + (A_2 \times SHGC_2 \times E_{W2}) + \dots]$$

where—

- $A_{1, 2, \text{etc}}$ = the area of each *glazing* element; and
- $U_{1, 2, \text{etc}}$ = the *Total System U-Value* of each *glazing* element; and
- $SHGC_{1, 2, \text{etc}}$ = the *Total System SHGC* for each *glazing* element; and
- $E_{W1, W2 \text{ etc}}$ = the winter exposure factor for each *glazing* element obtained from [Tables 3.12.2.2a](#) to [3.12.2.2g](#), as appropriate.

Explanatory information:

1. Winter exposure factors are not needed for *climate zone* 1.
2. For exposure factors between those in [Tables 3.12.2.2a](#) to [3.12.2.1g](#), either use the next highest P/H or interpolate.
3. For exposure factors between those in [Tables 3.12.2.1h](#) to [3.12.2.2o](#), either use the next lowest P/H or interpolate.

- (b) The aggregate solar heat gain of the *glazing* in each storey, including any mezzanine, of a building must—
 - (i) not exceed the allowances resulting from multiplying the area of the storey, including any mezzanine, measured within the enclosing walls, by the constant C_{SHGC} obtained from [Tables 3.12.2.1a](#) to [3.12.2.1h](#), as appropriate; and
 - (ii) be calculated in accordance with the following calculation—

$$(A_1 \times SHGC_1 \times E_{S1}) + (A_2 \times SHGC_2 \times E_{S2}) + \dots$$

where—

- $A_{1, 2, \text{etc}}$ = the area of each *glazing* element; and
- $SHGC_{1, 2, \text{etc}}$ = the *Total System SHGC* for each *glazing* element; and

Energy Efficiency

$E_{S1, S2, \text{ etc}}$ = the summer exposure factor for each *glazing* element obtained from Tables 3.12.2.2h to 3.12.2.2o, as appropriate.

- (c) For the purposes of Tables 3.12.2.1a to 3.12.2.1h, the following applies:
- (i) A storey has Standard air movement if all *habitable rooms* comply with Part 3.12.4.
 - (ii) A storey has High air movement if the total *ventilation opening* area serving the *habitable room* is—
 - (A) in *climate zones* 1, 2, 3, 4 and 5, not less than that for Standard air movement without a ceiling fan or evaporative cooler, but with ceiling fans complying with 3.12.4.3 installed in all *habitable rooms*; or
 - (B) greater than or equal to twice that for Standard air movement without a ceiling fan or evaporative cooler.
 - (iii) Where the *ventilation opening* area serving the *habitable rooms* is between Standard and High, interpolation may be used to determine the applicable C_{SHGC} .
 - (iv) Where the floor construction of a storey, including a mezzanine, is partly in direct contact with the ground and partly suspended, the constants for conductance and solar heat gain are to be—
 - (A) interpolated between the constants for the two constructions in proportion to their respective areas; or
 - (B) those for a suspended floor.

Explanatory information:

1. The conductance formula for *climate zone* 1 differs from the formula for all other *climate zones* because there is little or no need for heating at any time of the year in *climate zone* 1. The conductance allowance is calculated to limit the rate of heat conduction through *glazing* into an air conditioned interior from a hotter outside environment. The limit is set at a level that allows the use of basic *glazing* systems in dwellings with average *glazing* areas whether or not they are air conditioned.
2. The conductance formula for *climate zones* 2 to 8 is based on wintertime conditions to account for the balance between potential solar gains and heat loss by conduction through *glazing*. The calculation favours orientations with higher potential solar gains in winter and the use of shading rather than glass toning. The improved insulation performance of *glazing* resulting from the calculations will also be beneficial under summertime conditions when outside temperatures exceed inside temperatures.
3. By referring to “*glazing* elements”, 3.12.2.1 requires *Total System U-Values* and *Total System SHGCs* to be assessed for the combined effect of glass and frames. The measurement of these *Total System U-Values* and *Total System SHGCs* is specified in the Technical Protocols and Procedures Manual for Energy Rating of Fenestration Products by the Australian Fenestration Rating Council (AFRC).
Various assessors using AFRC procedures might refer to their published performance values by slightly different terms including “U-factor” or “Uw” for *Total System U-Value* or “SHGC” for *Total System SHGC*. Such values can be used under 3.12.2.1 provided they measure the combined glass and frame performance according to AFRC requirements.
4. *Total System U-Values* and *Total System SHGC* are shown for some simple types of *glazing* elements in the table below. Lower figures indicate better *glazing* performance, although its effect on a dwelling’s energy efficiency can vary depending on the climate and orientation of the *glazing*. The table gives worst case assessments, which can be improved by obtaining generic or custom product assessments from suppliers, manufacturers, industry associations (including their online resources) and from competent assessors.

Worst case whole glazing element performance values

Glass description	Framing type	<i>Total System U-Value</i>	<i>Total System SHGC</i>
Single clear	Aluminum	7.9	0.81
Single clear	Timber or uPVC	5.6	0.77
Tinted single	Aluminum	7.9	0.65
Tinted single	Timber or uPVC	5.6	0.61
Clear double (3/6/3)	Aluminum	6.2	0.72
Clear double (3/6/3)	Timber or uPVC	3.8	0.68

5. Typical ranges of generic ratings are set out in the table below to illustrate the levels of performance available through such assessments. Numbers from this table should not be used in compliance calculations.

Energy Efficiency

Indicative ranges of whole glazing element performance—single glazed (monolithic or laminated)—aluminum frame

Glass description	Comment	<i>Total System U-Value range</i>	<i>Total System SHGC range</i>
Clear	Minimum variation in glass U-Value and SHGC for different glass thicknesses.	7.9 - 5.5	0.81 - 0.64
Tinted	Glass SHGC depends on glass thickness and type of tint.	7.9 - 5.6	0.65 - 0.33
Coated	Glass U-Value and SHGC depend on coating type.	7.8 - 3.8	0.68 - 0.36
Tinted + coated	Glass U-Value depends on coating type. Glass SHGC depends on coating type, type of tint, and glass thickness.	7.8 - 3.8	0.45 - 0.31

Indicative ranges of whole glazing element performance—single glazed (monolithic or laminated)—timber or uPVC frame

Glass description	Comment	<i>Total System U-Value range</i>	<i>Total System SHGC range</i>
Clear	Minimum variation in glass U-Value and SHGC for different glass thicknesses.	5.6 - 4.3	0.77 - 0.51
Tinted	Glass SHGC depends on glass thickness and type of tint.	5.6 - 4.3	0.61 - 0.25
Coated	Glass U-Value and SHGC depend on coating type.	5.5 - 2.9	0.64 - 0.27
Tinted + coated	Glass U-Value depends on coating type. Glass SHGC depends on coating type, type of tint, and glass thickness.	5.5 - 3.1	0.42 - 0.23

Indicative ranges of whole glazing element performance—double glazed—aluminum frame

Glass description	Comment	<i>Total System U-Value range</i>	<i>Total System SHGC range</i>
Clear	Glass U-Value depends on cavity width.	6.2 - 3.1	0.72 - 0.63
Tinted	Glass U-Value depends on cavity width. Glass SHGC depends on type of tint, tinted glass thickness and on cavity width.	6.2 - 3.1	0.57 - 0.36
Coated	Glass U-Value depends on cavity width and type of coating. Glass SHGC depends on type of coating and cavity width.	6.1 - 2.4	0.60 - 0.22
Tinted + coated	Glass U-Value depends on cavity width and type of coating. Glass SHGC depends on type of coating,	6.1 - 2.5	0.41 - 0.21

Energy Efficiency

Glass description	Comment	Total System U-Value range	Total System SHGC range
	tinted glass thickness and cavity width.		

Indicative ranges of whole glazing element performance—double glazed—timber or uPVC

Glass description	Comment	Total System U-Value range	Total System SHGC range
Clear	Glass U-Value depends on cavity width.	3.8 - 2.5	0.68 - 0.47
Tinted	Glass U-Value depends on cavity width. Glass SHGC depends on type of tint, tinted glass thickness and on cavity width.	3.8 - 2.5	0.57 - 0.27
Coated	Glass U-Value depends on cavity width and type of coating. Glass SHGC depends on type of coating and cavity width.	3.8 - 2.1	0.59 - 0.17
Tinted + coated	Glass U-Value depends on cavity width and type of coating. Glass SHGC depends on type of coating, tinted glass thickness and cavity width.	3.8 - 2.1	0.37 - 0.16

- Custom assessments consider *glazing* element components in most detail and return the highest levels of assessed performance for a given type of *glazing* element. Generic assessments consider the components of *glazing* elements in less detail and return lower levels of assessed performance.
- The calculations for conductance and solar heat gain both consider seasonal solar radiation, orientation, shading and the solar performance of the *glazing*.

Table 3.12.2.1a Constants for conductance and solar heat gain—*climate zone 1*

Floor construction	Air movement (refer 3.12.2.1(c))	Constant C _U	Constant C _{SHGC}
Floor in direct contact with the ground	Standard	1.650	0.063
Floor in direct contact with the ground	High	1.650	0.069
Suspended floor	Standard	1.485	0.057
Suspended floor	High	1.485	0.063

Table 3.12.2.1b Constants for conductance and solar heat gain—*climate zone 2*

Floor construction	Air movement (refer 3.12.2.1(c))	Constant C _U	Constant C _{SHGC}
Floor in direct contact with	Standard	18.387	0.074

Energy Efficiency

Floor construction	Air movement (refer 3.12.2.1(c))	Constant C_U	Constant C_{SHGC}
the ground			
Floor in direct contact with the ground	High	18.387	0.081
Suspended floor	Standard	16.548	0.067
Suspended floor	High	16.548	0.074

Table 3.12.2.1c Constants for conductance and solar heat gain—*climate zone 3*

Floor construction	Air movement (refer 3.12.2.1(c))	Constant C_U	Constant C_{SHGC}
Floor in direct contact with the ground	Standard	14.641	0.062
Floor in direct contact with the ground	High	14.641	0.068
Suspended floor	Standard	13.177	0.056
Suspended floor	High	13.177	0.062

Table 3.12.2.1d Constants for conductance and solar heat gain—*climate zone 4*

Floor construction	Air movement (refer 3.12.2.1(c))	Constant C_U	Constant C_{SHGC}
Floor in direct contact with the ground	Standard	7.929	0.097
Floor in direct contact with the ground	High	7.929	0.107
Suspended floor	Standard	7.136	0.087
Suspended floor	High	7.136	0.096

Table 3.12.2.1e Constants for conductance and solar heat gain—*climate zone 5*

Floor construction	Air movement (refer 3.12.2.1(c))	Constant C_U	Constant C_{SHGC}
Floor in direct contact with the ground	Standard	13.464	0.122
Floor in direct contact with the ground	High	13.464	0.134
Suspended floor	Standard	12.118	0.110
Suspended floor	High	12.118	0.121

Table 3.12.2.1f Constants for conductance and solar heat gain—*climate zone 6*

Floor construction	Air movement (refer 3.12.2.1(c))	Constant C_U	Constant C_{SHGC}
Floor in direct contact with the ground	Standard	6.418	0.153
Floor in direct contact with the ground	High	6.418	0.168
Suspended floor	Standard	5.776	0.138
Suspended floor	High	5.776	0.152

Table 3.12.2.1g Constants for conductance and solar heat gain—*climate zone 7*

Floor construction	Air movement (refer 3.12.2.1(c))	Constant C_U	Constant C_{SHGC}
Floor in direct contact with	Standard	5.486	0.189

Energy Efficiency

Floor construction	Air movement (refer 3.12.2.1(c))	Constant C_U	Constant C_{SHGC}
the ground			
Floor in direct contact with the ground	High	5.486	0.208
Suspended floor	Standard	4.937	0.170
Suspended floor	High	4.937	0.187

Table 3.12.2.1h Constants for conductance and solar heat gain—*climate zone 8*

Floor construction	Air movement (refer 3.12.2.1(c))	Constant C_U	Constant C_{SHGC}
Floor in direct contact with the ground	Standard	3.987	0.234
Floor in direct contact with the ground	High	3.987	0.257
Suspended floor	Standard	3.588	0.211
Suspended floor	High	3.588	0.232

Explanatory information:

1. A floor in direct contact with the ground includes a concrete slab-on-ground or concrete slab-on-fill.
2. A suspended floor includes a suspended timber floor, suspended steel-framed floor or suspended concrete floor.
3. In general, a floor in direct contact with the ground more readily assimilates solar heat gains than a suspended floor. Consequently, lower stringency levels apply to *glazing* in a storey that has a floor in direct contact with the ground.
4. Whether a storey has Standard or High air movement depends upon the total *ventilation opening* area provided to *habitable rooms* on that storey and the presence of ceiling fans. The additional *ventilation opening* area *required* for High air movement without fans can be distributed to any of the *habitable rooms* on the storey. In *climate zones 1 to 5*, the storey can achieve High air movement when the total *ventilation opening* area is as for Standard air movement (without a ceiling fan or evaporative cooler) but with ceiling fans installed in every *habitable rooms*. For example, in *climate zone 2*:

Air movement—with/without ceiling fans

Air movement	With ceiling fans	Without ceiling fans
Standard	10%	7.5%
High	20%	10%

5. The provisions of 3.12.2 assume that internal *window* coverings will be installed for privacy reasons. This assumption is already incorporated in the allowances for *glazing*.

Table 3.12.2.2a Orientation Sector (refer Figure 3.12.2.1) winter exposure factor (E_w) for *climate zone 2*

P/H (refer Figure 3.12.2.2)	North	North east	East	South east	South	South west	West	North west
0.00	1.86	1.44	0.86	0.40	0.37	0.41	0.91	1.48
0.05	1.80	1.37	0.80	0.34	0.31	0.36	0.84	1.42
0.10	1.73	1.33	0.76	0.32	0.29	0.34	0.81	1.34
0.20	1.51	1.18	0.68	0.29	0.27	0.30	0.73	1.20
0.40	1.25	0.95	0.54	0.24	0.23	0.25	0.61	0.99
0.60	1.04	0.78	0.48	0.21	0.20	0.22	0.51	0.83
0.80	0.78	0.62	0.39	0.18	0.19	0.20	0.44	0.68
1.00	0.54	0.53	0.32	0.17	0.18	0.17	0.37	0.56
1.20	0.33	0.42	0.28	0.15	0.17	0.16	0.35	0.46
1.40	0.28	0.36	0.23	0.14	0.16	0.15	0.31	0.38

Energy Efficiency

P/H (refer Figure 3.12.2.2)	North	North east	East	South east	South	South west	West	North west
1.60	0.22	0.29	0.22	0.14	0.15	0.14	0.26	0.34
1.80	0.19	0.25	0.19	0.13	0.14	0.13	0.23	0.28
2.00	0.15	0.19	0.17	0.12	0.14	0.13	0.22	0.27

Table 3.12.2.2b Orientation Sector (refer Figure 3.12.2.1) winter exposure factor (E_w) for *climate zone 3*

P/H (refer Figure 3.12.2.2)	North	North east	East	South east	South	South west	West	North west
0.00	1.92	1.49	0.88	0.32	0.25	0.33	0.95	1.56
0.05	1.90	1.44	0.82	0.28	0.22	0.29	0.91	1.52
0.10	1.76	1.37	0.87	0.27	0.21	0.28	0.87	1.44
0.20	1.57	1.22	0.70	0.24	0.20	0.25	0.78	1.30
0.40	1.25	1.00	0.60	0.20	0.18	0.21	0.67	1.08
0.60	0.94	0.77	0.48	0.18	0.17	0.18	0.54	0.87
0.80	0.63	0.61	0.43	0.16	0.15	0.17	0.46	0.70
1.00	0.42	0.52	0.35	0.14	0.14	0.16	0.41	0.56
1.20	0.29	0.40	0.31	0.13	0.14	0.14	0.34	0.48
1.40	0.23	0.36	0.25	0.12	0.13	0.13	0.30	0.41
1.60	0.17	0.31	0.24	0.11	0.12	0.12	0.29	0.34
1.80	0.15	0.22	0.19	0.11	0.12	0.11	0.24	0.31
2.00	0.13	0.22	0.18	0.10	0.12	0.11	0.22	0.27

Table 3.12.2.2c Orientation Sector (refer Figure 3.12.2.1) winter exposure factor (E_w) for *climate zone 4*

P/H (refer Figure 3.12.2.2)	North	North east	East	South east	South	South west	West	North west
0.00	1.97	1.51	0.83	0.39	0.35	0.39	0.85	1.53
0.05	1.93	1.45	0.76	0.33	0.29	0.33	0.79	1.47
0.10	1.91	1.40	0.74	0.31	0.28	0.31	0.75	1.42
0.20	1.62	1.28	0.67	0.28	0.25	0.28	0.68	1.28
0.40	1.48	1.09	0.56	0.24	0.22	0.24	0.58	1.10
0.60	1.22	0.90	0.49	0.21	0.19	0.21	0.49	0.90
0.80	1.06	0.74	0.43	0.19	0.18	0.19	0.44	0.75
1.00	0.85	0.66	0.37	0.17	0.16	0.17	0.37	0.64
1.20	0.61	0.51	0.33	0.15	0.16	0.16	0.34	0.56
1.40	0.47	0.47	0.30	0.14	0.15	0.15	0.30	0.47
1.60	0.34	0.41	0.28	0.14	0.14	0.14	0.26	0.41
1.80	0.26	0.35	0.25	0.13	0.14	0.13	0.24	0.35
2.00	0.24	0.32	0.22	0.12	0.13	0.12	0.22	0.29

Table 3.12.2.2d Orientation Sector (refer Figure 3.12.2.1) winter exposure factor (E_w) for *climate zone 5*

P/H (refer Figure 3.12.2.2)	North	North east	East	South east	South	South west	West	North west
0.00	2.01	1.48	0.77	0.39	0.37	0.39	0.85	1.58
0.05	1.95	1.42	0.70	0.33	0.31	0.33	0.78	1.51
0.10	1.95	1.36	0.66	0.31	0.30	0.32	0.75	1.47
0.20	1.63	1.21	0.59	0.28	0.27	0.28	0.67	1.32
0.40	1.49	1.00	0.49	0.24	0.23	0.24	0.55	1.10

Energy Efficiency

P/H (refer Figure 3.12.2.2)	North	North east	East	South east	South	South west	West	North west
0.60	1.21	0.83	0.40	0.21	0.21	0.21	0.47	0.90
0.80	0.98	0.68	0.35	0.19	0.19	0.19	0.42	0.73
1.00	0.80	0.52	0.28	0.17	0.18	0.17	0.36	0.63
1.20	0.54	0.46	0.25	0.16	0.17	0.16	0.29	0.50
1.40	0.40	0.34	0.21	0.15	0.16	0.15	0.28	0.43
1.60	0.28	0.30	0.19	0.14	0.14	0.13	0.23	0.36
1.80	0.22	0.25	0.16	0.13	0.14	0.13	0.20	0.32
2.00	0.18	0.19	0.15	0.12	0.14	0.12	0.19	0.24

Table 3.12.2.2e Orientation Sector (refer Figure 3.12.2.1) winter exposure factor (E_w) for *climate zone 6*

P/H (refer Figure 3.12.2.2)	North	North east	East	South east	South	South west	West	North west
0.00	1.90	1.43	0.80	0.45	0.43	0.45	0.88	1.53
0.05	1.84	1.35	0.73	0.38	0.36	0.38	0.81	1.45
0.10	1.82	1.30	0.70	0.36	0.34	0.36	0.76	1.42
0.20	1.56	1.17	0.62	0.32	0.30	0.32	0.70	1.30
0.40	1.43	1.03	0.53	0.27	0.26	0.27	0.60	1.10
0.60	1.22	0.86	0.45	0.23	0.23	0.23	0.52	0.95
0.80	1.08	0.73	0.38	0.21	0.21	0.22	0.46	0.79
1.00	0.86	0.58	0.34	0.19	0.19	0.19	0.39	0.69
1.20	0.70	0.54	0.29	0.18	0.17	0.18	0.36	0.58
1.40	0.53	0.41	0.26	0.16	0.17	0.17	0.32	0.52
1.60	0.44	0.37	0.22	0.15	0.16	0.15	0.28	0.44
1.80	0.32	0.30	0.21	0.14	0.15	0.14	0.27	0.40
2.00	0.25	0.27	0.20	0.13	0.14	0.14	0.24	0.32

Table 3.12.2.2f Orientation Sector (refer Figure 3.12.2.1) winter exposure factor (E_w) for *climate zone 7*

P/H (refer Figure 3.12.2.2)	North	North east	East	South east	South	South west	West	North west
0.00	2.08	1.63	0.83	0.38	0.35	0.38	0.75	1.50
0.05	2.01	1.56	0.77	0.32	0.29	0.32	0.69	1.44
0.10	2.01	1.53	0.73	0.30	0.28	0.30	0.66	1.41
0.20	1.89	1.43	0.68	0.27	0.25	0.27	0.60	1.28
0.40	1.62	1.24	0.58	0.23	0.21	0.23	0.50	1.13
0.60	1.49	1.09	0.50	0.20	0.19	0.20	0.44	0.96
0.80	1.27	0.94	0.44	0.18	0.17	0.18	0.39	0.83
1.00	1.16	0.83	0.41	0.16	0.16	0.16	0.34	0.71
1.20	0.91	0.70	0.34	0.15	0.15	0.15	0.30	0.63
1.40	0.83	0.68	0.33	0.14	0.14	0.14	0.27	0.48
1.60	0.64	0.49	0.30	0.13	0.13	0.12	0.25	0.45
1.80	0.52	0.47	0.24	0.12	0.13	0.12	0.23	0.39
2.00	0.39	0.39	0.24	0.11	0.12	0.12	0.20	0.33

Energy Efficiency

Table 3.12.2.2g Orientation Sector (refer Figure 3.12.2.1) winter exposure factor (E_w) for *climate zone 8*

P/H (refer Figure 3.12.2.2)	North	North east	East	South east	South	South west	West	North west
0.00	1.93	1.48	0.81	0.47	0.45	0.47	0.81	1.46
0.05	1.87	1.41	0.73	0.39	0.38	0.39	0.73	1.39
0.10	1.85	1.36	0.70	0.37	0.35	0.37	0.70	1.34
0.20	1.56	1.22	0.63	0.33	0.32	0.33	0.63	1.20
0.40	1.41	1.02	0.51	0.28	0.27	0.28	0.51	0.99
0.60	1.18	0.83	0.44	0.24	0.24	0.24	0.44	0.82
0.80	1.00	0.68	0.37	0.21	0.22	0.21	0.36	0.67
1.00	0.79	0.59	0.32	0.20	0.20	0.19	0.30	0.58
1.20	0.54	0.46	0.28	0.18	0.19	0.18	0.27	0.47
1.40	0.44	0.42	0.25	0.17	0.18	0.17	0.24	0.38
1.60	0.31	0.31	0.21	0.16	0.17	0.15	0.22	0.32
1.80	0.23	0.28	0.19	0.14	0.16	0.14	0.19	0.29
2.00	0.19	0.25	0.16	0.14	0.15	0.14	0.17	0.23

Table 3.12.2.2h Orientation Sector (refer Figure 3.12.2.1) summer exposure factor (E_s) for *climate zone 1*

P/H (refer Figure 3.12.2.2)	North	North east	East	South east	South	South west	West	North west
0.00	0.52	0.84	1.29	1.24	0.87	1.27	1.32	0.85
0.05	0.44	0.74	1.19	1.13	0.75	1.17	1.23	0.75
0.10	0.41	0.68	1.11	1.07	0.68	1.09	1.15	0.69
0.20	0.37	0.59	1.01	0.94	0.55	0.94	1.00	0.60
0.40	0.30	0.45	0.79	0.69	0.42	0.75	0.83	0.47
0.60	0.25	0.37	0.66	0.59	0.34	0.60	0.66	0.38
0.80	0.22	0.31	0.53	0.47	0.30	0.52	0.58	0.32
1.00	0.19	0.26	0.45	0.41	0.25	0.43	0.48	0.28
1.20	0.18	0.23	0.37	0.33	0.22	0.39	0.42	0.26
1.40	0.17	0.21	0.32	0.30	0.22	0.32	0.37	0.22
1.60	0.15	0.18	0.28	0.26	0.18	0.29	0.34	0.21
1.80	0.13	0.18	0.27	0.22	0.17	0.28	0.30	0.18
2.00	0.12	0.17	0.23	0.21	0.16	0.24	0.28	0.17

Table 3.12.2.2i Orientation Sector (refer Figure 3.12.2.1) summer exposure factor (E_s) for *climate zone 2*

P/H (refer Figure 3.12.2.2)	North	North east	East	South east	South	South west	West	North west
0.00	0.72	1.05	1.22	1.04	0.72	1.12	1.34	1.11
0.05	0.60	0.92	1.10	0.92	0.60	1.01	1.23	0.99
0.10	0.55	0.85	1.04	0.86	0.57	0.94	1.14	0.90
0.20	0.47	0.74	0.92	0.76	0.50	0.84	1.00	0.78
0.40	0.39	0.56	0.73	0.61	0.40	0.67	0.83	0.60
0.60	0.33	0.44	0.60	0.49	0.33	0.55	0.67	0.45
0.80	0.29	0.37	0.50	0.41	0.29	0.46	0.58	0.39
1.00	0.26	0.30	0.43	0.35	0.24	0.40	0.47	0.32
1.20	0.23	0.27	0.35	0.30	0.22	0.34	0.41	0.28
1.40	0.21	0.24	0.32	0.28	0.21	0.30	0.36	0.24
1.60	0.19	0.23	0.28	0.25	0.19	0.27	0.31	0.22

Energy Efficiency

P/H (refer Figure 3.12.2.2)	North	North east	East	South east	South	South west	West	North west
1.80	0.17	0.20	0.24	0.22	0.17	0.26	0.28	0.20
2.00	0.17	0.19	0.22	0.21	0.16	0.22	0.27	0.19

Table 3.12.2.2j Orientation Sector (refer Figure 3.12.2.1) summer exposure factor (E_s) for *climate zone 3*

P/H (refer Figure 3.12.2.2)	North	North east	East	South east	South	South west	West	North west
0.00	0.56	1.04	1.42	1.18	0.66	1.16	1.36	1.01
0.05	0.47	0.94	1.32	1.08	0.57	1.05	1.26	0.90
0.10	0.44	0.85	1.25	1.02	0.54	0.99	1.19	0.83
0.20	0.38	0.73	1.10	0.90	0.46	0.87	1.06	0.73
0.40	0.32	0.56	0.88	0.71	0.38	0.72	0.84	0.56
0.60	0.28	0.43	0.74	0.58	0.31	0.57	0.71	0.44
0.80	0.24	0.35	0.59	0.47	0.27	0.50	0.60	0.35
1.00	0.20	0.29	0.50	0.40	0.24	0.43	0.53	0.29
1.20	0.19	0.26	0.42	0.34	0.21	0.37	0.43	0.26
1.40	0.17	0.22	0.35	0.31	0.20	0.32	0.41	0.23
1.60	0.17	0.20	0.33	0.27	0.16	0.31	0.35	0.21
1.80	0.15	0.19	0.30	0.24	0.16	0.28	0.33	0.19
2.00	0.15	0.18	0.25	0.24	0.15	0.24	0.27	0.17

Table 3.12.2.2k Orientation Sector (refer Figure 3.12.2.1) summer exposure factor (E_s) for *climate zone 4*

P/H (refer Figure 3.12.2.2)	North	North east	East	South east	South	South west	West	North west
0.00	0.72	1.19	1.40	1.05	0.57	0.99	1.31	1.12
0.05	0.61	1.10	1.31	0.97	0.49	0.91	1.22	1.02
0.10	0.56	1.00	1.24	0.91	0.46	0.85	1.17	0.94
0.20	0.43	0.87	1.12	0.82	0.41	0.76	1.05	0.81
0.40	0.30	0.66	0.92	0.67	0.34	0.62	0.85	0.62
0.60	0.27	0.50	0.74	0.56	0.29	0.53	0.72	0.45
0.80	0.24	0.38	0.63	0.49	0.25	0.45	0.59	0.36
1.00	0.20	0.31	0.55	0.42	0.22	0.39	0.51	0.30
1.20	0.19	0.26	0.46	0.37	0.20	0.35	0.45	0.25
1.40	0.16	0.23	0.39	0.34	0.17	0.33	0.38	0.21
1.60	0.16	0.20	0.38	0.30	0.16	0.29	0.33	0.20
1.80	0.14	0.18	0.32	0.27	0.14	0.25	0.32	0.17
2.00	0.13	0.17	0.28	0.23	0.14	0.24	0.26	0.16

Table 3.12.2.2l Orientation Sector (refer Figure 3.12.2.1) summer exposure factor (E_s) for *climate zone 5*

P/H (refer Figure 3.12.2.2)	North	North east	East	South east	South	South west	West	North west
0.00	0.82	1.09	1.19	0.96	0.68	1.04	1.30	1.16
0.05	0.69	0.96	1.07	0.85	0.57	0.92	1.19	1.04
0.10	0.63	0.88	1.01	0.79	0.54	0.86	1.11	0.94
0.20	0.51	0.76	0.89	0.70	0.48	0.76	0.99	0.83
0.40	0.39	0.58	0.71	0.57	0.38	0.62	0.81	0.62
0.60	0.35	0.46	0.58	0.47	0.33	0.51	0.65	0.48

Energy Efficiency

P/H (refer Figure 3.12.2.2)	North	North east	East	South east	South	South west	West	North west
0.80	0.30	0.37	0.50	0.40	0.28	0.43	0.52	0.40
1.00	0.26	0.31	0.42	0.34	0.25	0.37	0.46	0.31
1.20	0.24	0.26	0.36	0.30	0.22	0.33	0.40	0.27
1.40	0.21	0.23	0.32	0.27	0.20	0.29	0.34	0.24
1.60	0.20	0.22	0.29	0.23	0.18	0.27	0.30	0.21
1.80	0.18	0.20	0.25	0.21	0.17	0.23	0.27	0.20
2.00	0.17	0.17	0.24	0.21	0.16	0.21	0.25	0.19

Table 3.12.2.2m Orientation Sector (refer Figure 3.12.2.1) summer exposure factor (E_s) for *climate zone 6*

P/H (refer Figure 3.12.2.2)	North	North east	East	South east	South	South west	West	North west
0.00	0.84	1.08	1.15	0.87	0.61	1.05	1.40	1.24
0.05	0.71	0.97	1.05	0.78	0.52	0.96	1.30	1.13
0.10	0.65	0.90	0.99	0.74	0.49	0.91	1.25	1.04
0.20	0.52	0.77	0.88	0.65	0.44	0.82	1.12	0.91
0.40	0.36	0.58	0.71	0.54	0.36	0.67	0.90	0.69
0.60	0.30	0.43	0.61	0.45	0.31	0.58	0.76	0.51
0.80	0.26	0.35	0.50	0.38	0.26	0.50	0.66	0.40
1.00	0.22	0.29	0.42	0.32	0.23	0.42	0.56	0.36
1.20	0.20	0.24	0.37	0.29	0.23	0.39	0.48	0.29
1.40	0.18	0.22	0.32	0.26	0.19	0.34	0.42	0.26
1.60	0.16	0.19	0.28	0.24	0.18	0.31	0.38	0.21
1.80	0.15	0.18	0.26	0.22	0.17	0.28	0.34	0.20
2.00	0.14	0.17	0.24	0.21	0.17	0.26	0.31	0.17

Table 3.12.2.2n Orientation Sector (refer Figure 3.12.2.1) summer exposure factor (E_s) for *climate zone 7*

P/H (refer Figure 3.12.2.2)	North	North east	East	South east	South	South west	West	North west
0.00	0.96	1.17	1.21	0.94	0.64	0.91	1.19	1.18
0.05	0.83	1.05	1.10	0.83	0.54	0.81	1.09	1.07
0.10	0.76	0.97	1.04	0.80	0.51	0.76	1.03	0.98
0.20	0.62	0.85	0.93	0.70	0.45	0.68	0.91	0.86
0.40	0.40	0.65	0.76	0.58	0.38	0.55	0.74	0.64
0.60	0.32	0.51	0.65	0.50	0.33	0.47	0.63	0.51
0.80	0.28	0.40	0.54	0.44	0.28	0.41	0.53	0.40
1.00	0.25	0.33	0.48	0.37	0.25	0.35	0.44	0.32
1.20	0.22	0.28	0.41	0.34	0.23	0.31	0.38	0.27
1.40	0.19	0.23	0.36	0.30	0.21	0.28	0.33	0.24
1.60	0.18	0.21	0.33	0.27	0.20	0.26	0.31	0.21
1.80	0.17	0.20	0.28	0.24	0.18	0.24	0.27	0.19
2.00	0.16	0.19	0.27	0.23	0.18	0.21	0.25	0.18

Table 3.12.2.2o Orientation Sector (refer Figure 3.12.2.1) summer exposure factor (E_s) for *climate zone 8*

P/H (refer Figure 3.12.2.2)	North	North east	East	South east	South	South west	West	North west
0.00	0.85	1.12	1.20	0.96	0.68	1.01	1.27	1.16

Energy Efficiency

P/H (refer Figure 3.12.2.2)	North	North east	East	South east	South	South west	West	North west
0.05	0.71	0.99	1.09	0.85	0.57	0.90	1.16	1.04
0.10	0.65	0.90	1.02	0.79	0.54	0.84	1.09	0.95
0.20	0.52	0.79	0.90	0.70	0.48	0.73	0.98	0.83
0.40	0.39	0.60	0.73	0.57	0.39	0.61	0.79	0.63
0.60	0.34	0.46	0.60	0.48	0.33	0.50	0.66	0.49
0.80	0.30	0.37	0.50	0.41	0.29	0.43	0.53	0.40
1.00	0.25	0.30	0.42	0.35	0.25	0.37	0.47	0.33
1.20	0.23	0.28	0.37	0.31	0.23	0.33	0.39	0.26
1.40	0.21	0.23	0.32	0.29	0.20	0.29	0.34	0.24
1.60	0.20	0.21	0.30	0.25	0.18	0.25	0.31	0.22
1.80	0.19	0.20	0.25	0.22	0.17	0.23	0.28	0.20
2.00	0.16	0.18	0.23	0.21	0.16	0.22	0.24	0.19

Explanatory information:

- Higher exposure factor (E_w) values in Tables 3.12.2.2a to 3.12.2.2g indicate greater exposure to desirable winter solar gains and should be adopted as far as possible.
- Higher exposure factor (E_s) values in Tables 3.12.2.2h to 3.12.2.2o indicate greater exposure to unwanted summer solar gains and should be avoided as far as possible.

Figure 3.12.2.1 Orientation sectors

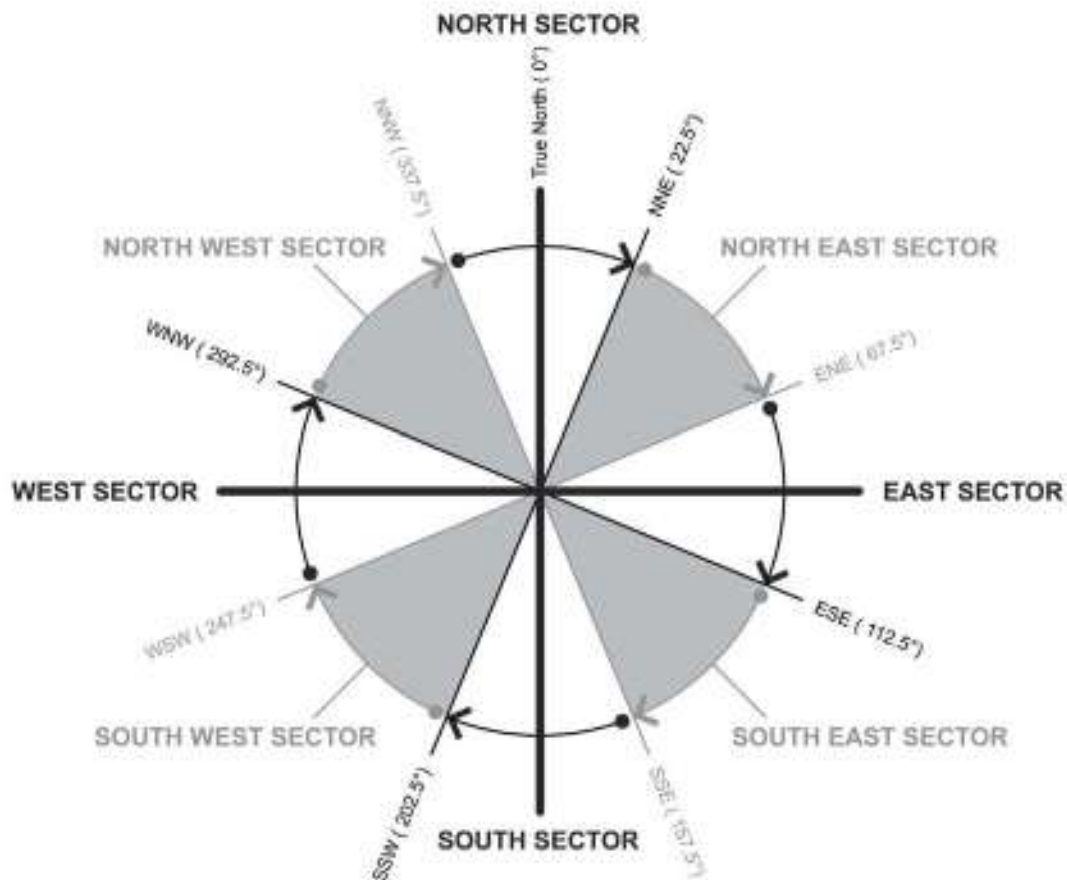

Explanatory information:

Energy Efficiency

1. The orientation sector for a wall or *glazing* element is the sector that contains a line drawn perpendicular to the face of the wall or *glazing* element.
2. [Figure 3.12.2.1](#) is based on True North and all angles are measured clockwise from True North. Survey angles on site plans are usually marked in angles from True North. These angles can be used to establish True North for a particular site.
3. Magnetic North, found by a magnetic compass, varies from True North over time and by different amounts in different locations. Magnetic North is not an acceptable approximation of True North.
4. The eight orientation sectors shown in [Figure 3.12.2.1](#) do not overlap at their boundaries. For example, north sector begins just clockwise after the NNW line and ends exactly on the NNE line. The start and end of other sectors are determined in a similar way, as indicated by the outer curved arrows.

Figure 3.12.2.2 Method of measuring p and h

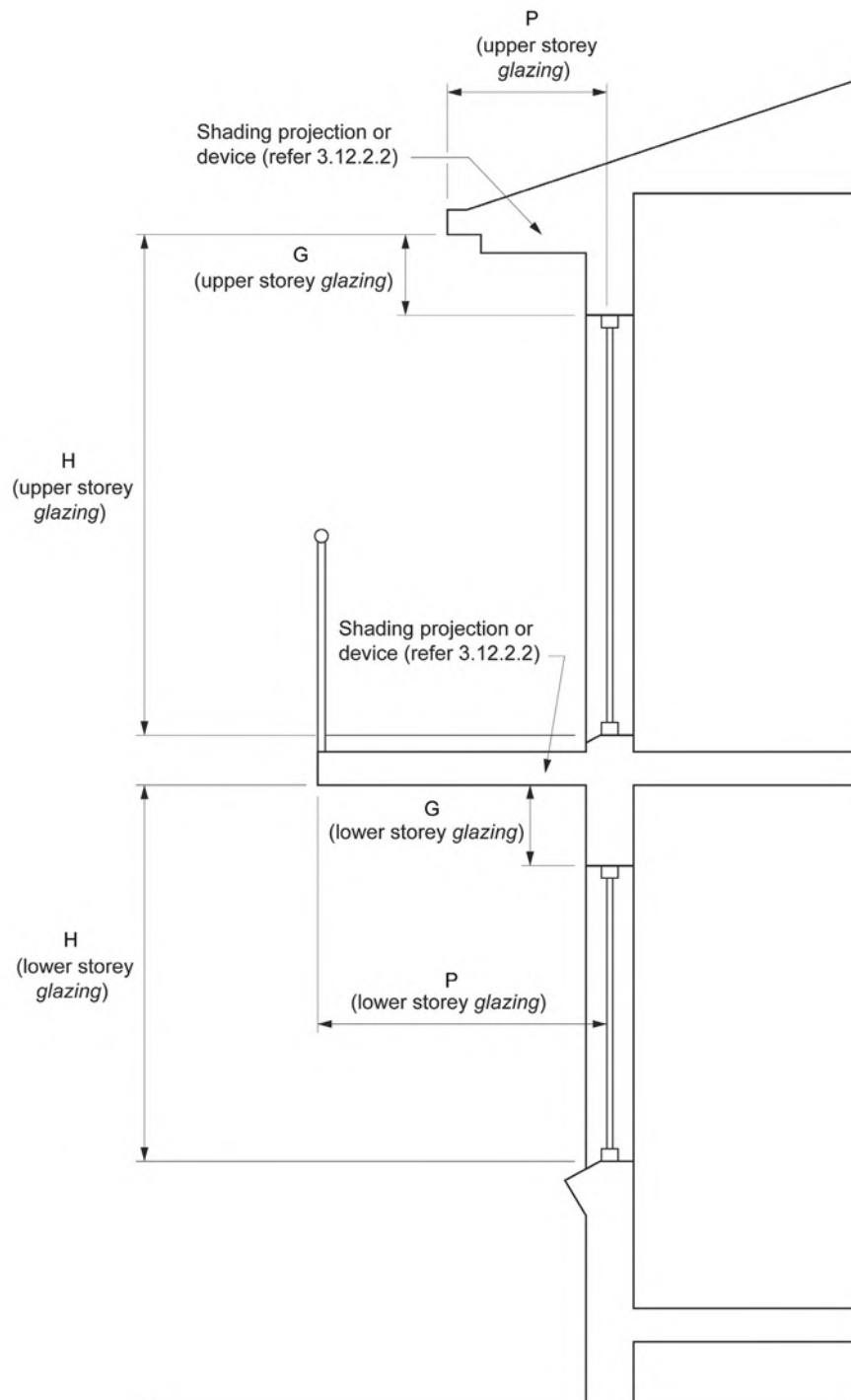
**Notes to Figure 3.12.2.2:**

1. An external shading device that complies with 3.12.2.2(b) is considered to achieve a P/H value of 2.00.
2. Where G exceeds 500 mm, the value of P must be halved.

3.12.2.2 Shading

Where shading is *required* to comply with 3.12.2.1, it must—

- (a) be provided by an external permanent projection, such as a verandah, balcony, fixed canopy, eaves, shading hood or carport, which—
 - (i) extends horizontally on both sides of the *glazing* for a distance greater than or equal to the projection distance P in Figure 3.12.2.2; or

Energy Efficiency

- (ii) provide the equivalent shading to (i) with a reveal or the like; or
- (b) be provided by an external shading device, such as a shutter, blind, vertical or horizontal building screen with blades, battens or slats, which—
 - (i) is capable of restricting at least 80% of the summer solar radiation; and
 - (ii) if adjustable, is readily operated either manually, mechanically or electronically by the building occupants.

Explanatory information:

1. Shading devices can include fixed louvres, shading screens and other types of perforated or fixed angle slatted shades. However, such devices need to be designed for the climate and latitude to ensure that summer sun penetration is restricted, while winter sun access is achieved. Winter access refers to the availability of winter solar gains to offset conducted heat losses.
2. The impact of shading is assessed with respect to the solar heat gain for the window. The requirements of 3.12.2.1 considers solar heat gain to be either beneficial or detrimental to the energy efficiency of a building based on seasonal variation (winter/summer), *climate zone*, orientation and P/H. Higher P/H values are more beneficial in minimising summer solar heat gain where as lower P/H values are more beneficial in allowing winter access.
3. Gutters can only be considered as providing shading if attached to a shading projection such as a verandah, fixed canopy, eaves, shading hood, balcony or the like.
4. Shading devices can be either attached or located adjacent to the building. For example, a free-standing lattice screen may be considered to provide shading to *glazing* if it complies with 3.12.2.2(b).
5. An adjustable shading device in Part 3.12.2.2(b)(ii) should be readily operated from a safe location or platform that does not require ladders, rigging, harnessing, or the like.

Part 3.12.3 Building sealing

3.12.3 Application

- (a) This Part applies to—
- (i) a Class 1 building; and
 - (ii) a Class 10a building with a *conditioned space*.
- (b) The provisions of (a) do not apply to the following:
- (i) A building in *climate zones* 1, 2, 3 and 5 where the only means of air-conditioning is by using an evaporative cooler.
 - (ii) A permanent building *ventilation opening* that is necessary for the safe operation of a gas appliance.

Explanatory information:

1. An evaporatively-cooled building in *climate zones* 4 and 6 must be sealed because of the likelihood of the building being heated during colder periods.
2. Appropriate ventilation requirements for gas appliances can be obtained from relevant legislation, referenced standards and product installation manuals.

Acceptable Construction Practice

3.12.3.1 Chimneys and flues

The chimney or flue of an open solid-fuel burning appliance must be provided with a damper or flap that can be closed to seal the chimney or flue.

Explanatory information:

1. The requirements of this Part are to be read in conjunction with the fire safety requirements in [Part 3.10.7](#).
2. A solid-fuel burning appliance is a heater that burns material such as timber, coal and the like. This clause does not apply to gas and liquid fuel burning appliances.

3.12.3.2 Roof lights

- (a) A *roof light* must be sealed, or capable of being sealed, when serving—
- (i) a *conditioned space*; or
 - (ii) a *habitable room* in *climate zones* 4, 5, 6, 7 and 8.
- (b) A *roof light required* by (a) to be sealed, or capable of being sealed, must be constructed with—
- (i) an imperforate ceiling diffuser or the like installed at the ceiling or internal lining level; or
 - (ii) a weatherproof seal; or
 - (iii) a shutter system readily operated either manually, mechanically or electronically by the occupant.

Explanatory information:

A *roof light* should be sealed regardless of which room it serves in *climate zones* 4, 5, 6, 7 and 8. For example, a *roof light* located in a hallway should be sealed to stop the transfer of cold air into adjoining *conditioned space*. This principle also applies to external doors and *windows*, exhaust fans, ceiling, wall and floor junctions, and evaporative coolers.

3.12.3.3 External windows and doors

- (a) An external door, internal door between a Class 1 building and an unconditioned Class 10a building, openable *window* and other such opening must be sealed when serving—
- (i) a *conditioned space*; or
 - (ii) a *habitable room* in *climate zones* 4, 5, 6, 7 and 8.

- (b) A seal to restrict air infiltration—
 - (i) for the bottom edge of a door, must be a draft protection device; and
 - (ii) for the other edges of a door or the edges of an openable *window* or other such opening, may be a foam or rubber compressible strip, fibrous seal or the like.
- (c) A *window* complying with the maximum air infiltration rates specified in AS 2047 need not comply with (b)(ii).

3.12.3.4 Exhaust fans

An exhaust fan must be fitted with a sealing device such as a self-closing damper, filter or the like when serving—

- (a) a *conditioned space*; or
- (b) a *habitable room* in *climate zones* 4, 5, 6, 7 and 8.

Explanatory information:

An exhaust fan is considered to be adequately sealed if it is fitted with a filter such as the type commonly used in kitchen range hoods.

3.12.3.5 Construction of ceilings, walls and floors

- (a) Ceilings, walls, floors and any opening such as a *window* frame, door frame, *roof light* frame or the like must be constructed to minimise air leakage in accordance with (b) when forming part of the external fabric of—
 - (i) a *conditioned space*; or
 - (ii) a *habitable room* in *climate zones* 4, 5, 6, 7 and 8.
- (b) Construction *required* by (a) must be—
 - (i) enclosed by internal lining systems that are close fitting at ceiling, wall and floor junctions; or
 - (ii) sealed at junctions and penetrations with—
 - (A) close-fitting architrave, skirting or cornice; or
 - (B) expanding foam, rubber compressive strip, caulking or the like.

Explanatory information:

1. A close fitting internal lining system is considered to include an allowance for minimum lining movement gaps at wall, floor and ceiling junctions.
2. Caulking includes sealant, mastic or other gap filling material.
3. In 3.12.3.5(b)(ii), penetrations include windows, doors, roof lights, flues, exhaust fans, heating and cooling ductwork and the like.

3.12.3.6 Evaporative coolers

An evaporative cooler must be fitted with a self-closing damper or the like when serving—

- (a) a heated space; or
- (b) a *habitable room* in *climate zones* 4, 5, 6, 7 or 8.

Explanatory information:

The self-closing damper should create an effective seal against air infiltration.

Part 3.12.4 Air movement

3.12.4 Application

This Part applies to a *habitable room* in a Class 1 building.

Acceptable Construction Practice

3.12.4.1 Air movement

- (a) Air movement must be provided to *habitable rooms* in accordance with [Table 3.12.4.1](#).
- (b) Air movement *required* by (a) may be provided through an opening from an adjoining room (including an enclosed verandah) if—
 - (i) the adjoining room is not a *sanitary compartment*; and
 - (ii) the opening between the adjoining room and the *habitable room* complies with [Table 3.12.4.1](#) as if it were a *ventilation opening* to the *habitable room* or a proportion thereof if some ventilation is provided from another source; and
 - (iii) the *ventilation opening* to the adjoining room complies with [Table 3.12.4.1](#) for the *floor area* of the adjoining room and the proportion of the *habitable room* that is ventilated from the adjoining room.
- (c) The requirements of (a) do not apply to buildings in Region D severe tropical cyclone areas (see [Figure 3.10.1.4](#)) provided the *external walls* are shaded with a verandah, balcony, eaves, carport or the like that projects at a minimum angle of 15 degrees in accordance with [Figure 3.12.1.2](#).

Table 3.12.4.1 Minimum total ventilation opening area as a percentage of the floor area for each habitable room

Climate zone	Without a ceiling fan or evaporative cooler	With a ceiling fan	With an evaporative cooler
1	10%	7.5%	10% (see Note)
2	10%	7.5%	10% (see Note)
3	10%	7.5%	7.5%
4	10%	5%	5%
5	7.5%	5%	7.5% (see Note)
6, 7 and 8	As <i>required</i> by Part 3.8.5	As <i>required</i> by Part 3.8.5	As <i>required</i> by Part 3.8.5

Note to Table 3.12.4.1: Because evaporative coolers are less effective than ceiling fans in more humid locations, the requirement for *ventilation opening* in *climate zones* 1, 2 and 5 with an evaporative cooler is the same as without one.

Explanatory information:

In humid locations, such as Darwin and Cairns, evaporative coolers would not provide the same cooling effect as in dryer climates. Although they would provide some benefit from the air movement if operated in a “fan-only” mode, they would cause discomfort, possible *condensation* and possible mould growth if operated in an evaporative “water-on” mode. However, even though a concession is not given in *climate zones* 1, 2 and 5, there are locations, particularly in *climate zone* 5, where evaporative coolers would be effective.

3.12.4.2 Ventilation openings

- (a) In *climate zones* 1, 2, 3, 4 and 5, the total *ventilation opening* area *required* by [Table 3.12.4.1](#) to a *habitable room* must—
 - (i) be connected by a breeze path complying with (b) to another *ventilation opening* in another room or space; or
 - (ii) be provided by a minimum of two *ventilation openings* located within the same *habitable room*, with each *ventilation opening* having an area of not less than 25% of the area *required* by [Table 3.12.4.1](#).
- (b) A breeze path *required* by (a)(i) must—
 - (i) pass through not more than two openings in the internal walls with each opening having an area of not less than 1.5 m²; and

- (ii) have a distance along the breeze path between *ventilation openings* of not more than 20 m.

Explanatory information:

1. *Ventilation openings* should be designed to allow the interior of the building to take full advantage of any natural breeze. Careful consideration should be given to the type and location of openings to ensure optimum effect is achieved and that internal “dead air pockets” are avoided.
2. An opening may serve more than one breeze path.
3. Two openings are stated in (b)(i) as the limit of the number of openings permitted in a breeze path. These are typically doorways. Larger openings, such as those between adjoining lounge and dining areas in the same space are unlikely to restrict air movement significantly.

3.12.4.3 Ceiling fans and evaporative coolers

Ceiling fans or evaporative coolers *required* to comply with 3.12.0.1, Tables 3.12.2.1a to 3.12.2.1h, as appropriate or Table 3.12.4.1 must—

- (a) be permanently installed; and
- (b) have a speed controller; and
- (c) for ceiling fans, serve the whole room, with the *floor area* that a single fan serves not exceeding—
 - (i) 15 m² if it has a blade rotation diameter of greater than or equal to 900 mm; and
 - (ii) 25 m² if it has a blade rotation diameter of greater than or equal to 1200 mm.

Part 3.12.5 Services

3.12.5 Application

This Part applies to—

- (a) a Class 1 building; and
- (b) a Class 10a building; and
- (c) a Class 10b *swimming pool* associated with a Class 1 or 10a building.

Acceptable Construction Manual

3.12.5.0 Application

A heated water supply system must be designed and installed in accordance with Part B2 of NCC Volume Three — Plumbing Code of Australia.

Acceptable Construction Practice

3.12.5.1 Insulation of services

Thermal insulation for central heating water *pipng* and heating and cooling ductwork must—

- (a) be protected against the effects of weather and sunlight; and
- (b) be able to withstand the temperatures within the *pipng* or ductwork; and
- (c) use thermal insulation material in accordance with AS/NZS 4859.1.

Explanatory information:

The central heating water *pipng* provisions apply to systems designed to heat the building via water, such as a hydronic heating system.

3.12.5.2 Central heating water piping

Central heating water *pipng* that is not within a *conditioned space* must be thermally insulated to achieve the minimum material *R-Value* as follows:

- (a) Internal *pipng* including—
 - (i) flow and return *pipng* that is—
 - (A) within an unventilated wall space; or
 - (B) within an internal floor between storeys; or
 - (C) between ceiling insulation and a ceiling; and
 - (ii) heated water piping encased within a concrete floor slab (except that which is part of a floor heating system), must, in all *climate zones*, have a minimum material *R-Value* of 0.4.
- (b) *Pipng* located within a ventilated wall space, an enclosed building subfloor or a roof space, including—
 - (i) flow and return *pipng*; and
 - (ii) cold water supply *pipng* within 500 mm of the connection to the central water heating system; and
 - (iii) relief valve *pipng* within 500 mm of the connection to the central water heating system, must have a minimum material *R-Value* of—
 - (iv) in *climate zones* 1, 2, 3 and 5 — 0.6; and
 - (v) in *climate zones* 4, 6 and 7 — 0.9; and
 - (vi) in *climate zone* 8 — 1.3.

Energy Efficiency

- (c) *Piping* located outside the building or in an unenclosed building subfloor or roof space, including—
- (i) flow and return *piping*; and
 - (ii) cold water supply *piping* within 500 mm of the connection to the central water heating system; and
 - (iii) relief valve *piping* within 500 mm of the connection to the central water heating system,
- must have a minimum material *R-Value* of—
- (iv) in *climate zones* 1, 2, 3 and 5 — 0.6; and
 - (v) in *climate zones* 4, 6 and 7 — 1.3; and
 - (vi) in *climate zone* 8 — 1.3.

Explanatory information:

1. The insulation levels in the following table are typical examples of materials that can be used to insulate central heating water *piping* calculated in accordance with AS/NZS 4859.1.
2. The *R-Value* is that of the insulation and not the *Total R-Value* of the pipe, air film and insulation. Where *piping* has a significant inherent *R-Value* it may be subtracted from the material *R-Value* required. However, the inherent *R-Value* of most *piping* material is not sufficient to satisfy the requirements in 3.12.5.2.
3. *Piping* within a timber member, such as that passing through a wall stud, is considered to have sufficient insulation for the purposes of 3.12.5.2.
4. The following table provides examples for the *R-Value* of the insulation used for smaller diameter *piping*.

R-Value of the insulation used for smaller diameter piping

Insulation	<i>R-Value</i>
9 mm of closed cell polymer	0.4
13 mm of closed cell polymer	0.6
19 mm of closed cell polymer	0.9
25 mm of closed cell polymer	1.3
25 mm of glasswool	1.3

3.12.5.3 Heating and cooling ductwork

- (a) Heating and cooling ductwork and fittings must—
- (i) achieve the material *R-Value* in 3.12.5.3(d); and
 - (ii) be sealed against air loss—
 - (A) by closing all openings in the surface, joints and seams of ductwork with adhesives, mastics, sealants or gaskets in accordance with AS 4254.1 and AS 4254.2 for a Class C seal; or
 - (B) for flexible ductwork, with a draw band in conjunction with a sealant or adhesive tape.
- (b) Duct insulation must—
- (i) abut adjoining duct insulation to form a continuous barrier; and
 - (ii) be installed so that it maintains its position and thickness, other than at flanges and supports; and
 - (iii) where located outside the building, under a suspended floor, in an attached Class 10a building or in a roof space—
 - (A) be protected by an outer sleeve of protective sheeting to prevent the insulation becoming damp; and
 - (B) have the outer protective sleeve sealed with adhesive tape not less than 48 mm wide creating an airtight and waterproof seal.
- (c) The requirements of (a) do not apply to heating and cooling ductwork and fittings located within the insulated building *envelope* including a service riser within the *conditioned space*, internal floors between storeys and the like.

Explanatory information:

Ductwork within a fully insulated building may still benefit from insulation particularly when the system is only operating for short periods.

Energy Efficiency

In some *climate zones* condensation may create problems with uninsulated ductwork, in which case insulation should still be considered.

- (d) The material *R-Value required* by (a)(i) must be determined in accordance with the following:
- (i) In a heating-only system or cooling-only system including an evaporative cooling system—
 - (A) ductwork must have a minimum material *R-Value* of—
 - (aa) in *climate zones* 1 to 7 — 1.0; and
 - (bb) in *climate zone* 8 — 1.5; and
 - (B) fittings must have a minimum material *R-Value* of 0.4.
 - (ii) In a combined heating and refrigerated cooling system—
 - (A) ductwork must have a minimum material *R-Value* of—
 - (aa) in *climate zones* 1, 3, 4, 6 and 7 — 1.5; and
 - (bb) in *climate zones* 2 and 5 — 1.0; and
 - (cc) in *climate zone* 8 — 1.5; and
 - (B) fittings must have a minimum material *R-Value* of 0.4.
 - (iii) For the purposes of (d)(ii)(A), the minimum material *R-Value required* for ductwork may be reduced by 0.5 for combined heating and refrigerated cooling systems in *climate zones* 1, 3, 4, 6 and 7 if the ducts are—
 - (A) under a suspended floor with an enclosed perimeter; or
 - (B) in a roof space that has an insulation of greater than or equal to R0.5 directly beneath the roofing.

Explanatory information:

1. For information on an enclosed perimeter, refer to the explanatory information following [Table 3.12.1.4](#).
2. Insulation for refrigerated cooling ductwork should have a vapour barrier to prevent possible damage by condensation.
3. The insulation levels in the following tables are typical examples of materials that can be used to insulate ductwork and the *R-Values* they contribute. Other methods are available for meeting the minimum material *R-Value* required by [3.12.5.3\(d\)](#). These values do not take into account all issues that may reduce the effectiveness of insulation. AS/NZS 4859.1 should be used to confirm in-situ values.
4. For fittings, 11 mm polyurethane typically provides an *R-Value* of 0.4.

R-Values for typical ductwork insulation materials — flexible ductwork

Insulating material and thickness	<i>R-Value</i>
45 mm glasswool (11 kg/m ³)	1.0
70 mm polyester (6.4 kg/m ³)	1.0
63 mm glasswool (11 kg/m ³)	1.5
90 mm polyester (8.9 kg/m ³)	1.5
85 mm glasswool (11 kg/m ²)	2.0

R-Values for typical ductwork insulation materials — sheetmetal ductwork — external insulation

Insulating material and thickness	<i>R-Value</i>
38 mm glasswool (22 kg/m ³)	1.0
50 mm polyester (20kg/m ³)	1.1
50 mm glasswool (22 kg/m ³)	1.5
75 mm polyester (20kg/m ³)	1.7

R-Values for typical ductwork insulation materials — sheetmetal ductwork — internal insulation

Insulating material and thickness	<i>R-Value</i>
38 mm glasswool (32 kg/m ³)	1.0

Energy Efficiency

Insulating material and thickness	<i>R-Value</i>
50 mm polyester (32 kg/m ³)	1.3
50 mm glasswool (32 kg/m ³)	1.5

5. Any flexible ductwork used for the transfer of products, initiating from a heat source that contains a flame, must also have the fire hazard properties *required* by 3.7.1.2.

3.12.5.4 Electric resistance space heating

An electric resistance space heating system that serves more than one room must have—

- (a) separate isolating switches for each room; and
- (b) a separate temperature controller and time switch for each group of rooms with common heating needs; and
- (c) power loads of not more than 110 W/m² for living areas, and 150 W/m² for bathrooms.

3.12.5.5 Artificial lighting

- (a) The *lamp power density* or *illumination power density* of artificial lighting, excluding heaters that emit light, must not exceed the allowance of—
 - (i) 5 W/m² in a Class 1 building; and
 - (ii) 4 W/m² on a verandah, balcony or the like attached to a Class 1 building; and
 - (iii) 3 W/m² in a Class 10a building associated with a Class 1 building.
- (b) The *illumination power density* allowance in (a) may be increased by dividing it by the relevant *illumination power density* adjustment factor for a control device in (f) as applicable.
- (c) When designing the *lamp power density* or *illumination power density*, the power of the proposed installation must be used rather than nominal allowances for exposed batten holders or luminaires.

Explanatory information:

1. There are two approaches available for achieving compliance with (a) in Class 1 and associated Class 10a buildings. These are through the determination of the *lamp power density* or the *illumination power density*.
2. The first step in achieving compliance is to determine the relevant *lamp power density* or *illumination power density* allowance. Generally the *lamp power density* or *illumination power density* is the relevant value in (a)(i), (ii) or (iii), however the *illumination power density* allowance can be increased in accordance with (b) if a control device is used.
 When *illumination power density* and one or more control devices are used, the adjustment factor is only applied to the space(s) served by the control device. The adjusted allowance for this space is then combined with the allowances for the remaining spaces using an area weighted average, which subsequently increases the allowance provided in (a)(i), (ii) or (iii).
 When no control device is used, the adjustment factor is equal to 1.
 The second step in achieving compliance is to assess the overall *lamp power density* or overall *illumination power density* of the building.
3. The overall *lamp power density* is calculated by adding the maximum power ratings of all the permanently wired lamps in a space and dividing this sum by the area of the space.
4. The overall *illumination power density* is calculated by adding the illumination power load for each space and dividing this sum by the area of the space.
 Control device adjustment factors in (b) are only applied to the *illumination power density*, not the overall *illumination power density*.
5. To comply with (a), the overall *lamp power density* or overall *illumination power density* must be less than or equal to the allowance.
6. Trading of allowances between (a)(i), (ii) and (iii) is not permitted.
7. (a)(ii) includes outdoor living spaces such as verandahs, balconies, patios, alfresco spaces or the like that are attached to a Class 1 building.
8. The artificial lighting requirements in 3.12.5.5 are to be read in conjunction with the artificial lighting requirements

Energy Efficiency

in 3.8.4.3.

- (d) If halogen lamps are installed, they must be separately switched from fluorescent lamps.
- (e) Artificial lighting around the perimeter of a building must—
 - (i) be controlled by a daylight sensor; or
 - (ii) have an average light source efficacy of not less than 40 Lumens/W.

Explanatory information:

The artificial lighting around the perimeter of a building does not need to comply to a maximum power density as neither the lighting required or the area of the space can be easily defined. Instead, external lights are required to be controlled by daylight sensors or to be efficient.

In (d), separate switching is required for halogen lamps to facilitate less frequent usage. This is because they are significantly less energy efficient than fluorescent lamps.

- (f) The following *illumination power density* adjustment factors apply to control devices for artificial lighting:
 - (i) Lighting timer for corridor lighting: 0.7.
 - (ii) Motion detector —
 - (A) 0.9, where —
 - (aa) at least 75% of the area of a space is controlled by one or more motion detectors; or
 - (bb) an area of less than 200 m² is switched as a block by one or more motion detectors; and
 - (B) 0.7, where up to 6 lights are switched as a block by one or more detectors; and
 - (C) 0.55, where up to 2 lights are switched as a block by one or more detectors.
 - (iii) Manual dimming system where not less than 75% of the area of a space is controlled by manually operated dimmers: 0.85.
 - (iv) Programmable dimming system where not less than 75% of the area of a space is controlled by programmable dimmers: 0.85.
 - (v) Dynamic dimming system, with automatic compensation for lumen depreciation, the design lumen depreciation factor is not less than —
 - (A) 0.9 for fluorescent lights; or
 - (B) 0.8 for high pressure discharge lights.
 - (vi) Fixed dimming where at least 75% of the area is controlled by fixed dimmers that reduce the overall lighting level and the power consumption of the lighting — equal to the % of full power to which the dimmer is set divided by 0.95.
 - (vii) Daylight sensor and dynamic lighting control device, with dimmed or stepped switching of lights adjacent to *windows*:
 - (A) Lights within the space adjacent to *windows* other than *roof lights* for a distance from the *window* equal to the depth of the floor at *window* head height: 0.5.
 - (B) Lights within the space adjacent to *roof lights*: 0.6.
- (g) For the purposes of (f)(iii), manual dimming is where lights are controlled by a knob, slider or other mechanism or where there are pre-selected scenes that are manually selected.
- (h) For the purposes of (f)(iv), programmed dimming is where pre-selected scenes or levels are automatically selected by the time of day, photoelectric cell or occupancy sensor.
- (i) For the purposes of (f)(v), dynamic dimming is where the lighting level is varied automatically by a photoelectric cell to either proportionately compensate for the availability of daylight or the lumen depreciation of the lamps.
- (j) For the purposes of (f)(vi), fixed dimming is where lights are controlled to a level and that level cannot be adjusted by the user.
- (k) For the purposes of (f)(vii)(A) and (B), the *illumination power density* adjustment factor is only applied to lights controlled by that item — this adjustment factor does not apply to tungsten halogen or other incandescent sources.

3.12.5.6 Water heater in a heated water supply system

A water heater in a heated water supply system must be designed and installed in accordance with Part B2 of NCC Volume Three — Plumbing Code of Australia.

3.12.5.7 Swimming pool heating and pumping

- (a) Heating for a *swimming pool* must be by—
- (i) a solar heater not boosted by electric resistance heating; or
 - (ii) a heater using reclaimed energy; or
 - (iii) a gas heater; or
 - (iv) a heat pump; or
 - (v) a combination of (i) to (iv).
- (b) Where some or all of the heating *required* by (a) is by a gas heater or a heat pump, the *swimming pool* must have—
- (i) a cover unless located in a *conditioned space*; and
 - (ii) a time switch to control the operation of the heater.
- (c) A time switch must be provided to control the operation of a circulation pump for a *swimming pool*.
- (d) For the purposes of 3.12.5.7, a *swimming pool* does not include a spa pool.

Explanatory information:

Some jurisdictions may have requirements for a pool cover under the Smart Approved WaterMark Scheme.

3.12.5.8 Spa pool heating and pumping

- (a) Heating for a spa pool that shares a water recirculation system with a *swimming pool* must be by—
- (i) a solar heater; or
 - (ii) a heater using reclaimed energy; or
 - (iii) a gas heater; or
 - (iv) a heat pump; or
 - (v) a combination of (i) to (iv).
- (b) Where some or all of the heating *required* by (a) is by a gas heater or a heat pump, the spa pool must have—
- (i) a cover; and
 - (ii) a push button and a time switch to control the operation of the heater.
- (c) A time switch must be provided to control the operation of a circulation pump for a spa pool having a capacity of 680 L or more.

State & Territory Appendices

Schedule 1 State & Territory Appendices

Schedule 1 State & Territory Appendices

Schedule 1 State & Territory Appendices

Schedule 1 **State & Territory Appendices**

Commonwealth of Australia

Australian Capital Territory

New South Wales

Northern Territory

Queensland

South Australia

Tasmania

Victoria

Western Australia

Commonwealth of Australia

Footnote: Other legislation and policies affecting buildings

Commonwealth of Australia

Footnote: Other legislation and policies affecting buildings

1. Australian Capital Territory
2. Defence Buildings
3. Disability Discrimination
4. Environment
5. Jervis Bay Territory
6. Occupational Health and Safety
7. Territory of Christmas Island

Footnote: Other legislation and policies affecting buildings

In addition to any applicable provisions of this Code, there are a number of other legislative technical requirements and policies affecting the design, construction and/or performance of buildings that practitioners may need to be aware of, including, but not necessarily limited to, the following list. Additional legislative instruments such as regulations, codes and standards may exist under the legislation listed.

1. Australian Capital Territory

Administering Agency

Department of Finance

Relevant Legislation

Australian Capital Territory (Planning and Land Management) Act 1988

Parliament Act 1974

2. Defence Buildings

Administering Agency

Department of Defence

Relevant Legislation

Defence Act 1903

Relevant Regulations

Defence Regulation 2016, Part 11A

Relevant Codes, Standards and Publications

Manual of Fire Protection Engineering

Requirements for the Provision of Disabled Access and other Facilities for People with a Disability in Defence

Heating, Ventilation and Air Conditioning Policy

Microbial Control in Air Handling and Water Systems of Defence Buildings

Building Energy Performance Manual

Manual of Infrastructure Engineering - Electrical

Manual of Infrastructure Engineering - Bulk Fuel Installation Design

Defence Communications Cabling Standard

Defence Training Area Management Manual

Defence Safety Manual

Defence Security Manual

Defence Explosive Ordinance Publications

The Defence Estate Quality Management System (<http://www.defence.gov.au/estatemangement/governance/policy/principlesdevelopment/default.asp>) contains further requirements including the principles of development, zone planning, site selection, engineering requirements and environmental impact assessment and approval requirements.

3. Disability Discrimination

Administering Agency

Attorney-General's Department

Relevant Legislation

Disability Discrimination Act 1992

Disability (Access to Premises - Buildings) Standards 2010

Disability Standards for Accessible Public Transport 2002

4. Environment

Administering Agency

Department of the Environment

Relevant Legislation

Environmental Protection and Biodiversity Conservation Act 1999

Environmental Protection and Biodiversity Conservation Regulations 2000

Administering Agency

Department of Industry

Relevant Policy

Energy Efficiency in Government Operations (2006)

5. Jervis Bay Territory

Administering Agency

Department of Infrastructure and Regional Development

Relevant Legislation

Jervis Bay Territory Acceptance Act 1915

6. Occupational Health and Safety

Administering Agency

Department of Employment

Relevant Legislation

Work Health and Safety Act 2011

Work Health and Safety Regulations 2011

7. Territory of Christmas Island

Administering Agency

Department of Infrastructure and Regional Development

Relevant Legislation

Christmas Island Act 1958

Australian Capital Territory

ACT Appendix

Footnote: Other legislation affecting buildings

Australian Capital Territory

ACT Appendix

Footnote: Other legislation affecting buildings

ACT Appendix

The Australian Capital Territory Appendix to the Building Code of Australia (BCA) Volume Two forms part of the ACT Building Code in accordance with the *Building Act 2004*. The ACT Appendix contains variations and additions to the BCA that apply to building work undertaken in the ACT and information about the application of the BCA in the ACT.

The ACT appendix is notified on the ACT Legislation Register and can be found at <https://www.legislation.act.gov.au/a/2004-11/> under the Regulations and Instruments tab. While the BCA text includes indicators of potential ACT-specific clauses, including variations and additions, not all current ACT-specific clauses may be indicated. Users of the BCA must check that they are using the version of the ACT Appendix currently in force and are applying all relevant variations and additions. Historical versions of the ACT Appendix are also available on the register.

Footnote: Other legislation affecting buildings

In addition to any applicable provisions of the *Building Act 2004* and this Code, there are other legislative technical requirements affecting the design, construction and/or performance of buildings that practitioners may need to be aware of. A list of relevant legislation and links to where it can be found on the ACT Legislation Register can be found in the ACT Appendix at <https://www.legislation.act.gov.au/a/2004-11/>.

New South Wales

New South Wales additions

New South Wales additions

New South Wales variations

Footnote: Other legislation affecting buildings

New South Wales

New South Wales additions

NSW 1 Garage top dwellings

Performance Requirements

- NSW 1.1.0 Definitions
- NSW 1.1.1 Fire separation
- NSW 1.1.2 Construction of floors
- NSW 1.1.3 Construction of walls
- NSW 1.1.4 Heat alarms

New South Wales additions

NSW 2 Energy efficiency

Performance requirements

NSW P2.6.2 Services

Verification methods

- NSW V2.6.1 Building Sealing

- NSW 3.12.1 Application of NSW Part 3.12.1
- NSW 3.12.1.1 Compliance with BCA provisions
- NSW 3.12.3 Application of NSW Part 3.12.3
- NSW 3.12.3.1 Compliance with BCA provisions

- NSW 3.12.5 Application of NSW Part 3.12.5
- NSW 3.12.5.1 Compliance with BCA provisions

New South Wales variations

- NSW Schedule 3 Definitions
- NSW Schedule 4 Schedule of referenced documents

Footnote: Other legislation affecting buildings

1. Boarding Houses
2. Children's Services
3. Crown Land – Construction Approval
4. Dining Rooms
5. Electrical Installations
6. Fire Prevention in Existing Buildings
7. Gas Installations
8. Historic Buildings
9. Lift Installations
10. Moveable Dwellings (in Caravan Parks)
11. Work Health and Safety
12. Planning Controls
13. Sanitary Plumbing, Water Supply and Sewerage
14. Septic Tank Installations
15. Sleeping Accommodation
16. Swimming Pool Fences

New South Wales additions

Application of New South Wales additions

This Appendix contains additional provisions for application in New South Wales as follows:

NSW 1 Garage top dwellings

Purpose

The purpose of [NSW 1](#) is to provide a suitable level of fire and life safety to occupants of a [garage top dwelling](#) located above a non-associated [private garage](#).

Unless otherwise stated, all applicable national provisions apply.

A dwelling located above a non-associated [private garage](#) is a permissible type of development under the NSW planning system. This Addition supports and complements NSW planning initiatives.

Note:

[NSW 1](#) contains [Deemed-to-Satisfy Provisions](#) additional to those contained in [Section 3](#) for buildings which are used as [garage top dwellings](#) and [private garages](#) which are attached to or associated with [garage top dwellings](#).

NSW 1 Garage top dwellings performance provisions

Performance Requirements

The provisions of the national BCA [Performance Requirements P2.3.1](#) and [P2.3.2](#) are applicable in NSW.

NSW 1.1 Garage top dwellings acceptable construction practice

Appropriate *Performance Requirements*

Where a *Performance Solution* to NSW 1.1 is proposed, that proposal must comply with—

- (a) *Performance Requirement P2.3.1*; and
- (b) *Performance Requirement P2.3.2*; and
- (c) relevant *Performance Requirements* determined in accordance with *A2.2(3)* and *A2.4(3)* as applicable.

NSW 1.1.0 Definitions

The following definition is used in this Part:

Garage top dwelling means a Class 1a dwelling located above a Class 10a *private garage* which is not associated with that Class 1a dwelling and includes any internal entry stair serving the *garage top dwelling*.

NSW 1.1.1 Fire separation

- (a) A *garage top dwelling* must be separated from a non-associated *private garage* by a floor complying with *NSW 1.1.2*.
- (b) Where a *garage top dwelling* is served by an internal stair, the *garage top dwelling* must be separated from a non-associated *private garage* by a wall complying with *NSW 1.1.3*.
- (c) Where a *garage top dwelling* is located above both associated and non-associated *private garages*—
 - (i) in addition to a floor *required* by (a), the *private garages* must be separated with a wall complying with *NSW 1.1.3*; or
 - (ii) where a *garage top dwelling* is not served by an internal stair, the *garage top dwelling* may be separated from the *private garages* by a floor complying with *NSW 1.1.2*.

NSW 1.1.2 Construction of floors

- (a) A floor *required* by *NSW 1.1.1(a)* or (c)(ii) must—
 - (i) have an FRL of not less than 30/30/30 when tested from the underside; or
 - (ii) have a *fire-protective covering* on the underside of the floor, including beams incorporated in it; or
 - (iii) be a floor/ceiling system incorporating a ceiling which has a *resistance to the incipient spread of fire* to the space above itself of not less than 60 minutes.
- (b) Where a floor subject to (a)(i) depends on direct vertical or lateral support from another part to maintain its FRL, that supporting part must have an FRL of not less than 30/-/-.
- (c) Where a service passes through a floor referred to in (a), the penetration must not reduce the fire performance of the floor or covering.

NSW 1.1.3 Construction of walls

- (a) A wall *required* by *NSW 1.1.1(b)* or (c)(i) must—
 - (i) have an FRL of not less than 30/30/30 when tested from the non-associated *private garage* side; or
 - (ii) be of masonry construction not less than 90 mm thick.
- (b) A wall subject to (a) must—
 - (i) commence at the footings or ground slab; and
 - (ii) extend to the underside of a floor complying with *NSW 1.1.2*.
- (c) A wall referred to in (a)(i), if of *lightweight construction* must be tested in accordance with *Specification C1.8* of BCA Volume One.
- (d) Where a service passes through a wall referred to in (a), the penetration must not reduce the fire performance of the wall.

- (e) A wall *required* by NSW 1.1.1(b) or (c)(i) need not comply with 3.7.3.2.

NSW 1.1.4 Heat alarms

- (a) A heat alarm must be installed in a *private garage* that is not associated with and located below, a *garage top dwelling*.
- (b) A heat alarm required by (a) must—
- (i) be located on or near the ceiling; and
 - (ii) comply with AS 1603.3; and
 - (iii) be connected to the consumer mains power supplying the *garage top dwelling* where consumer mains power is supplied to the building; and
 - (iv) be interconnected to and activate the *garage top dwelling* smoke alarms *required* by 3.7.5.3.
- (c) Durable notices must be permanently fixed to the *garage top dwelling* and non-associated *private garage* in prominent locations, indicating that—
- (i) a heat alarm is installed in the non-associated *private garage*; and
 - (ii) the heat alarm is interconnected to the *garage top dwelling* smoke alarms.

New South Wales additions

NSW 2 Energy efficiency

Note 1.

In NSW, Class 1 and 2 buildings, Class 4 parts of buildings, and certain Class 10 buildings are subject to BASIX (the Building Sustainability Index), the web-based planning tool designed to assess the potential performance of these buildings against a range of sustainability indices including thermal comfort and energy. Commitments made under BASIX become a condition of the relevant development consent or complying development certificate.

BASIX applies to these types of new buildings in NSW; to alterations and additions to buildings of those classes where the work is subject to BASIX; and also where an applicant elects to comply with BASIX.

The following provisions are therefore designed to complement requirements that arise under BASIX and which are implemented via the development consent.

Where BASIX is not applied to alterations and additions to these types of buildings, the provisions will also complement council development controls that require energy efficiency measures to be incorporated as part of the alterations and additions. For example: [NSW Part 3.12.1](#) specifies installation requirements for, and the standards that must be met by, insulation required by any of the foregoing.

Note 2.

All definitions in the national BCA that are applicable to the national BCA [Parts 2.6](#) and [3.12](#) are also applicable to [NSW Parts 2.6](#) and [3.12](#).

NSW Part 2.6 Energy efficiency performance provisions

Delete the Performance Requirements and Verification Methods of Part 2.6 and substitute NSW provisions as follows:

Performance requirements

NSW P2.6.1(a) Building Fabric

- (i) Thermal insulation in a building must be installed in a manner and have characteristics, which facilitate the efficient use of energy for artificial heating and cooling.
- (ii) A building must have, to the degree necessary, thermal breaks installed between the framing and external cladding, to facilitate efficient thermal performance of the building envelope.

Application:

- (a) [NSW P2.6.1\(a\)](#) only applies to thermal insulation in a Class 1 or 10 building where a development consent specifies that the insulation is to be provided as part of the development.
- (b) In (a), the term development consent has the meaning given by the Environmental Planning and Assessment Act 1979.
- (c) [NSW P2.6.1\(a\)\(ii\)](#) only applies to a metal framed roof and a metal framed wall.

Explanatory Information:

1. In NSW, provision of thermal insulation of the building fabric may be nominated as a commitment on a BASIX (Building Sustainability Index) Certificate and form part of the conditions of development consent or complying development certificate relating to the development.
2. BASIX is applicable to alterations and additions the cost of which exceeds specified minimum values, or where an applicant elects to comply with BASIX. Where BASIX is not applicable, a council's development controls may also specify the provision of thermal insulation in such alterations or additions.
3. Thermal breaks between metal framing and cladding material of minimum thickness will reduce energy loss and contribute to the efficient thermal performance of the building.

NSW P2.6.1(b) Building Sealing

A building must have, to the degree necessary, a level of building sealing against air leakage to facilitate the efficient use of energy for artificial heating and cooling appropriate to—

- (i) the function and use of the building; and
- (ii) the internal environment; and
- (iii) the geographic location of the building.

Limitation:

[NSW P2.6.1\(b\)](#) does not apply to—

- (a) existing buildings being relocated; or
- (b) Class 10a buildings—
 - (i) without a *conditioned space*; or
 - (ii) for the accommodation of vehicles; or
- (c) parts of buildings that cannot be fully enclosed; or
- (d) a permanent building opening, in a space where a gas appliance is located, that is necessary for the safe operation of a gas appliance; or
- (e) a building in *climate zones* 2 and 5 where the only means of *air-conditioning* is by using an evaporative cooler.

Explanatory Information:

1. The term “cannot be fully enclosed” means parts of buildings with permanent openings such as balconies, shade rooms, rooms with fixed louvres, mesh or other material that allows air flow. Adjustable louvres are considered to

provide full enclosure to the opening they accommodate.

Such rooms are unlikely to be conditioned given the high air flow rates; therefore application of the Performance Requirement to these parts of buildings would not result in reduction in energy use.

2. Appropriate ventilation for gas appliances can be obtained from relevant legislation, referenced standards and product installation manuals.

NSW P2.6.2 Services

Domestic services, including any associated distribution system and components must, to the degree necessary, have features that facilitate the efficient use of energy appropriate to—

- (a) the *domestic service* and its usage; and
- (b) the geographic location of the building; and
- (c) the location of the *domestic service*; and
- (d) the energy source.

Limitations:

- (a) [NSW P2.6.2](#) does not apply to existing services associated with existing buildings being relocated.
- (b) Compliance is not *required* with the national BCA provisions of [P2.6.2\(b\)](#) as the sources of energy are regulated under BASIX.

Verification methods

NSW V2.6.1 Building Sealing

Compliance with [NSW P2.6.1\(b\)](#) is verified when a building *envelope* is sealed in accordance with [V2.6.2.3](#) of the national provisions.

NSW Part 3.12.1**Building fabric thermal insulation****Appropriate *Performance Requirements***

Where a *Performance Solution* to NSW 3.12.1 is proposed, that proposal must comply with—

- (a) *Performance Requirement* NSW P2.6.1(a); and
- (b) relevant *Performance Requirements* determined in accordance with A2.2(3) and A2.4(3) as applicable.

NSW 3.12.1 Application of NSW Part 3.12.1

- (a) Compliance with NSW 3.12.1.1 satisfies NSW P2.6.1(a) for thermal insulation and thermal breaks.
- (b) NSW PART 3.12.1 only applies to thermal insulation in a Class 1 or 10 building where a development consent specifies that the insulation is to be provided as part of the development.
- (c) In (b), the term development consent has the meaning given by the Environmental Planning and Assessment Act 1979.
- (d) The *Deemed-to-Satisfy Provisions* of this Part for thermal breaks apply to all Class 1 buildings and Class 10a buildings with a *conditioned space*.

NSW 3.12.1.1 Compliance with BCA provisions

- (a) Thermal insulation in a building must comply with the national BCA provisions of 3.12.1.1.
- (b) A thermal break must be provided between the external cladding and framing in accordance with national BCA provisions of—
 - (i) 3.12.1.2(c) for a metal framed roof; and
 - (ii) 3.12.1.4(d) for a metal framed wall.
- (c) Compensation for reduction in ceiling insulation must comply with the national BCA provisions of 3.12.1.2(e).
- (d) A floor with an in-slab or in-screed heating or cooling system must comply with the national BCA provisions of—
 - (i) 3.12.1.5(a)(ii), (iii) and (e) for a suspended floor; or
 - (ii) 3.12.1.5(c), (d) and (e) for a concrete slab-on-ground.

NSW Part 3.12.2

External glazing

Note:

The national BCA [Part 3.12.2](#) does not apply in NSW as the subject matter is dealt with by BASIX.

NSW Part 3.12.3 Building sealing

Appropriate *Performance Requirements*

Where a *Performance Solution* to NSW 3.12.3 is proposed, that proposal must comply with—

- (a) *Performance Requirement* NSW P2.6.1(b); and
- (b) relevant *Performance Requirements* determined in accordance with A2.2(3) and A2.4(3) as applicable.

NSW 3.12.3 Application of NSW Part 3.12.3

- (a) Compliance with NSW 3.12.3.1 satisfies NSW P2.6.1(b) for building sealing.
- (b) NSW Part 3.12.3 is not applicable to—
 - (i) existing buildings being relocated; or
 - (ii) Class 10a buildings without a *conditioned space*; or
 - (iii) parts of buildings that cannot be fully enclosed; or
 - (iv) a permanent building opening, in a space where a gas appliance is located, that is necessary for the safe operation of a gas appliance; or
 - (v) a building in *climate zones* 2 and 5 where the only means of *air-conditioning* is by using an evaporative cooler.

NSW 3.12.3.1 Compliance with BCA provisions

The sealing of a building must comply with the national BCA provisions 3.12.3.1 to 3.12.3.6.

Explanatory Information:

1. The term “cannot be fully enclosed” means parts of buildings with permanent openings such as balconies, shade rooms, rooms with fixed louvres, mesh or other material that allows air flow. Adjustable louvres are considered to provide full enclosure to the opening they accommodate.
Such rooms are unlikely to be conditioned given the high air flow rates; therefore applications of the Performance Requirement to these parts of buildings would not result in reduction in energy use.
2. Appropriate ventilation for gas appliances can be obtained from relevant legislation, referenced standards and product installation manuals.

NSW Part 3.12.4

Air movement

Note:

The national BCA [Part 3.12.4](#) does not apply in NSW as the subject matter is dealt with by BASIX.

NSW Part 3.12.5

Services

Appropriate *Performance Requirements*

Where a *Performance Solution* to NSW 3.12.5 is proposed, that proposal must comply with—

- (a) *Performance Requirement* NSW P2.6.2; and
- (b) relevant *Performance Requirements* determined in accordance with A2.2(3) and A2.4(3) as applicable.

NSW 3.12.5 Application of NSW Part 3.12.5

- (a) Compliance with NSW 3.12.5.1 satisfies NSW P2.6.2 for services.
- (b) NSW Part 3.12.5 is not applicable to existing services associated with existing buildings being relocated.

NSW 3.12.5.1 Compliance with BCA provisions

Services must comply with the national BCA provisions 3.12.5.0 to 3.12.5.3A.

Explanatory Information:

Compliance is not *required* with the national BCA provisions 3.12.5.4 to 3.12.5.8 as those matters are regulated under BASIX.

New South Wales variations

Application of New South Wales variations

This Appendix contains variations for application in New South Wales as follows:

NSW Schedule 3 Definitions

Substitute the definition of *appropriate authority* as follows:

Appropriate authority means the relevant authority with the responsibility to determine the particular matter.

Substitute the definition of *designated bushfire prone area* as follows:

Designated bushfire prone area means land that:

- (a) has been designated under legislation; or
 - (b) has been identified under an environmental planning instrument, development control plan or in the course of processing and determining a development application,
- as land that can support a bushfire or is likely to be subject to bushfire attack.

Insert definition of *Planning for Bush Fire Protection* as follows:

Planning for Bush Fire Protection is as prescribed by the Environmental Planning and Assessment Regulation 2000.

Insert definition for *spa pool* as follows:

Spa pool is as defined in the Swimming Pools Act 1992

NSW Schedule 4 Schedule of referenced documents

Insert in Table 1 of Schedule 4 the following:

NSW Table 1 Schedule of referenced documents

No.	Date	Title	Volume Two
AS 1603 Part 3	2018	Automatic fire detection and alarm systems — Heat alarms See Note 1(b)	NSW 1.1.4
AS 1603 Part 3	1996	Automatic fire detection and alarm systems — Heat alarms See Note 1(a)	NSW 1.1.4
NSW Legislation	1979	Environmental Planning and Assessment Act	3.10.5.0, NSW P2.6.1, NSW Part 3.12.1
NSW Legislation	2000	Environmental Planning and Assessment Regulation	NSW Schedule 3
NSW Legislation	1992	Swimming Pools Act	P2.7.1, 3.10.1.0, NSW Schedule 3
NSW Legislation	2018	Swimming Pools Regulation	P2.7.1, 3.10.1.0

Notes associated with [NSW Table 1](#):

- (1) For AS 1603.3:
 - (a) The 1996 edition has been retained for a transitional period ending on 30 April 2022.
 - (b) Heat alarms complying with the 2018 edition of AS 1603.3 must be of class type A1 or A2.

Footnote: Other legislation affecting buildings

In addition to any applicable provisions of the Environmental Planning and Assessment Act 1979, the Environmental Planning and Assessment Regulation 2000 and this Code, there is a variety of other regulatory provisions, including legislation, regulation and departmental policies that impose requirements affecting the design, construction and/or performance of buildings in NSW.

The following is a non-definitive list of such provisions. It does not include Commonwealth provisions that may apply in NSW, nor planning and environmental standards that may impose building requirements in individual circumstances. It is meant as an indicative guide only and is not to be relied upon in any way as a substitute for further research, investigation and legal advice needed to determine building standards in individual circumstances.

1. Boarding Houses**Administering Agency**

Department of Family and Community Services – Ageing, Disability and Home Care

Relevant Legislation

Boarding Houses Regulation 2013

2. Children’s Services**Administering Agency**

NSW Department of Education

Relevant Legislation

Children (Education and Care Services National Law Application) Act 2010

Children (Education and Care Services) Supplementary Provisions Regulation 2012

3. Crown Land – Construction Approval**Administering Agency**

Department of Industry

Relevant Legislation

Crown Land Management Act 2016

Crown Land Management Regulation 2018

Administering Agency

NSW Rural Fire Service

Relevant Legislation

Rural Fires Act 1997

4. Dining Rooms**Administering Agency**

NSW Food Authority

Relevant Legislation

Food Regulation 2015

5. Electrical Installations**Administering Agency**

NSW Fair Trading

Relevant Legislation

Gas and Electricity (Consumer Safety) Regulation 2018

Gas and Electricity (Consumer Safety) Act 2017

Administering Agency

SafeWork NSW

Relevant Legislation

Work Health and Safety Regulation 2017

6. Fire Prevention in Existing Buildings

Administering Agency

Department of Planning and Environment

Relevant Legislation

Environmental Planning and Assessment Act 1979

Environmental Planning and Assessment Regulation 2000

7. Gas Installations

Administering Agency

Department of Planning and Environment, Energy, Water and Portfolio Strategy

Relevant Legislation

Gas Supply Act 1996

Gas Supply (Safety and Network Management) Regulation 2013

Administering Agency

NSW Fair Trading

Relevant Legislation

Gas and Electricity (Consumer Safety) Act 2017

Gas and Electricity (Consumer Safety) Regulation 2018

8. Historic Buildings

Administering Agency

Office of Environment and Heritage

Relevant Legislation

Heritage Regulation 2012

9. Lift Installations

Administering Agency

SafeWork NSW

Relevant Legislation

Work Health and Safety Regulation 2017

10. Moveable Dwellings (in Caravan Parks)

Administering Agency

Office of Local Government

Relevant Legislation

Local Government Act 1993

Administering Agency

Department of Planning and Environment

Relevant Legislation

Local Government (Manufactured Home Estates, Caravan Parks, Camping Grounds and Moveable Dwellings) Regulation 2005

11. Work Health and Safety

Administering Agency

SafeWork NSW

Relevant Legislation

Work Health and Safety Regulation 2017

12. Planning Controls

Administering Agency

Department of Planning and Environment

Relevant Legislation

Environmental Planning and Assessment Act 1979

Environmental Planning and Assessment Regulation 2000

13. Sanitary Plumbing, Water Supply and Sewerage

Administering Agency

Office of Local Government

Relevant Legislation

Local Government Act 1993

Local Government (General) Regulation 2005

Administering Agency

NSW Fair Trading

Relevant Legislation

Plumbing and Drainage Act 2011

Plumbing and Drainage Regulation 2017

Approval to Connect to Network Utility Operator's System

Refer to the Network Utility Operator for the current Act & Regulation

Hunter Water Act 1991

Sydney Water Act 1994

Water Industry Competition Act (WICA) 2006

14. Septic Tank Installations

Administering Agency

Office of Local Government

Relevant Legislation

Local Government Act 1993

Local Government (General) Regulation 2005

15. Sleeping Accommodation

Administering Agency

NSW Ministry of Health

Relevant Legislation

Public Health Regulation 2012

16. Swimming Pool Fences

Administering Agency

NSW Fair Trading

Relevant Legislation

Swimming Pools Act 1992

Swimming Pools Regulation 2018

Northern Territory

Northern Territory additions

Northern Territory variations

Footnote: Other legislation affecting buildings

Northern Territory

Northern Territory additions

Northern Territory variations

NT Schedule 4 Schedule of referenced documents

Footnote: Other legislation affecting buildings

1. Accommodation
2. Child Care
3. Crown Land
4. Electrical Installations
5. Fences — dividing
6. Gas Installations
7. Historic Building
8. Occupational Health and Safety
9. Planning Controls
10. Plumbing Installations
11. Stormwater Drainage (Municipal Roads)
12. Stormwater Drainage (Territory Roads)
13. Swimming Pools
14. Water Supply and Sewage Services

Northern Territory additions

The Northern Territory has no additions to the Housing Provisions.

Northern Territory variations

Applications of Northern Territory variations

This Appendix contains variations for application in the Northern Territory as follows:

NT Schedule 4 Schedule of referenced documents

Insert in Table 1 of Schedule 4 the following:

NT Table 1 Schedule of referenced documents

No.	Date	Title	Volume Two
BCA 2009	May 2009	Building Code of Australia	2.6 , 3.12

Footnote: Other legislation affecting buildings

In addition to any applicable provisions of the Building Act, Building Regulations and this Code, there are a number of other legislative technical requirements affecting the design, construction and/or performance of buildings that practitioners may need to be aware of, including, but not necessarily limited to, the following list. Additional legislative instruments such as regulations, codes and standards may exist under the legislation listed.

1. Accommodation

Administering Agency

Department of Health

Relevant Legislation

Public and Environmental Health Act

Public and Environmental Health Regulations

2. Child Care

Administering Agency

Department of Education

Relevant Legislation

Education and Care Services National Law

Education and Care Services National Regulations

3. Crown Land

Administering Agency

Department of Infrastructure, Planning and Logistics

Relevant Legislation

Crown Lands Act

4. Electrical Installations

Administering Agency

Department of Attorney-General and Justice (NT Worksafe)

Relevant Legislation

Electrical Workers and Contractors Act

Electricity Reform Act

Electricity Reform (Safety and Technical) Regulations

5. Fences — dividing

Administering Agency

Department of Attorney-General and Justice

Relevant Legislation

Fences Act

6. Gas Installations

Administering Agency

Department of Attorney-General and Justice (NT Worksafe)

Relevant Legislation

Dangerous Goods Act

Work Health (Occupational Health and Safety) Regulations

7. Historic Building

Administering Agency

Department of Tourism and Culture

Relevant Legislation

Heritage Act

8. Occupational Health and Safety

Administering Agency

Department of Attorney-General and Justice (NT Worksafe)

Relevant Legislation

Work Health and Safety (National Uniform Legislation) Act

9. Planning Controls

Administering Agency

Department of Infrastructure, Planning and Logistics

Relevant Legislation

Planning Act

Planning Scheme

10. Plumbing Installations

Administering Agency

Department of Infrastructure, Planning and Logistics

Relevant Legislation

Building Act

Building Regulations

Plumbers and Drainers Licensing Act

11. Stormwater Drainage (Municipal Roads)

Administering Agency

Council or Municipality in which building is located

Relevant Legislation

Local Government Act

12. Stormwater Drainage (Territory Roads)

Administering Agency

Department of Infrastructure, Planning and Logistics

Relevant Legislation

Control of Roads Act

13. Swimming Pools

Administering Agency

Department of Infrastructure, Planning and Logistics

Relevant Legislation

Swimming Pool Safety Act

14. Water Supply and Sewage Services

Administering Agency

Power and Water Corporation

Relevant Legislation

Water Supply and Sewerage Services Act

Water Supply and Sewerage Services Regulations

Queensland

Queensland additions

Queensland variations

Footnote: Other legislation affecting buildings

Queensland

Queensland additions

Queensland variations

Qld Schedule 3 Definitions

Qld Schedule 4 Schedule of referenced documents

Footnote: Other legislation affecting buildings

Queensland additions

Queensland has no additions to the Housing Provisions.

Queensland variations

Application of Queensland variations

This appendix contains variations for application in Queensland as follows:

Qld Schedule 3 Definitions

Substitute the definition of *primary building element* as follows:

Primary building element means—

- (a) a member of a building designed specially to take part of the building loads and includes roof, ceiling, floor, stairway or ramp and wall framing members including bracing members design for the specific purpose of acting as a brace to those members; and
- (b) door jambs, window frames and reveals, architraves and skirtings.

Qld Schedule 4 Schedule of referenced documents

Insert in Table 1 of Schedule 4 the following:

Qld Table 1 Schedule of referenced documents

No.	Date	Title	Volume Two
N/A	N/A	Queensland Government, Department of Agriculture, Fisheries and Forestry - Construction timbers in Queensland, Book 1 and Book 2: Properties and specifications for satisfactory performance of construction timbers in Queensland - Class 1 and 10 buildings (Houses, carports, garages, greenhouses and sheds)	3.4.3.0
N/A	N/A	Building Act 1975	P2.7.1, 3.10.1.0
		Queensland Development Code MP 4.1—Sustainable buildings	Part 3.12

Footnote: Other legislation affecting buildings

All legislative technical requirements affecting the design, construction and/or performance of buildings are consolidated into the Building Act 1975 and other legislative instruments under that Act, such as regulations, codes (including this Code) and standards.

South Australia

South Australia additions

South Australia additions

South Australia additions

South Australia variations

Footnote: Other legislation affecting buildings

South Australia

South Australia additions

SA Acceptable construction manual

SA 1 * * * * *

South Australia additions

Health and amenity

SA 2 Water efficiency

SA 3 Wet areas

SA 4 Swimming pool signage

South Australia additions

Safe movement and access

SA 4 * * * * *

SA 5 Access for people with a disability

SA 6 Access for inspection and maintenance

South Australia variations

SA Schedule 3 Definitions

SA Schedule 4 Schedule of referenced documents

Footnote: Other legislation affecting buildings

1. Accommodation
2. Asbestos Removal
3. Crown Land
4. Electrical Installations
5. Encroachments
6. Fences
7. Fire Prevention in Existing Buildings
8. Gas Installations
9. Historic Buildings
10. Housing
11. Lift Installations
12. Occupational Health and Safety
13. Sanitary Plumbing, Water Supply and Sewerage
14. Septic Tank and Grey Water Installations
15. Subdivision of Property
16. Waste Management and Environment Protection

South Australia additions

Application of South Australian additions

This Appendix contains additional provisions for application in South Australia as follows:

SA Acceptable construction manual

SA 1 * * * * *

This clause has been deliberately left blank.

South Australia additions

Health and amenity

SA 2 Water efficiency

Limitation:

SA 2 applies to new Class 1 buildings and, extensions to existing Class 1 buildings where the *roof catchment area* is not less than 50 m² —

- (a) located in *Council* areas, excluding the Municipal Council of Roxby Downs and the District Council of Coober Pedy and;
- (b) where an extension incorporates a water closet or a water heater or laundry cold water outlet.

For the purposes of this part, *Council* means: A municipal or district Council as constituted under the Local Government Act 1999.

SA 2.1 Performance provisions

Objective

The Objective is to efficiently use all available water supplies.

Functional Statements

A building is to be constructed in a way that efficiently uses all available water supplies to reduce the amount required from the mains reticulated water supply.

Performance Requirements

A building must provide an additional water supply (other than the mains reticulated potable water supply) which must be plumbed to at least a water closet or a water heater or all the cold water laundry outlets.

SA 2.2 Acceptable construction practice

SA 2.2.0 Definitions

The following definitions are used in this part:

Rainwater tank means a vessel for the storage of *surface water* collected from the *roof catchment area* of the building.

Roof catchment area means the area of the roof (expressed in square metres), measured on the horizontal (no allowance for slope or vertical surfaces) and includes the plan area of the gutters.

SA 2.2.1 Application

Compliance with the acceptable construction practice provisions of SA 2.2 for water efficiency satisfies *Performance Requirement SA 2.1*.

SA 2.2.2 Rainwater tank capacity

- (a) Where the *roof catchment area* of the building is not less than 50 m², the building must be designed to ensure that *surface water* run-off from not less than 50m² of the *roof catchment area* is:
 - (i) collected by a drainage system complying with [Clauses 3.5.1, 3.5.2 and 3.5.3](#) of the Building Code of Australia as applicable; and
 - (ii) stored in a *rainwater tank*, the storage capacity of which is not less than 1 kilolitre (1000 litres); and
 - (iii) plumbed to at least a water closet or a water heater or all laundry cold water outlets.
- (b) Where the *roof catchment area* of the building is less than 50m², all the *surface water* run-off from the *roof catchment area* must be collected, stored and plumbed in accordance with [\(a\)\(i\)](#), [\(a\)\(ii\)](#) and [\(a\)\(iii\)](#).

Explanatory information:

Clause SA 2.2.2 requires the *rainwater tank* to be plumbed to a water closet, water heater or all laundry cold water outlets. The Office of the Technical Regulator regulates plumbing work in South Australia under the *Water Industry Act 2012*, including the plumbing of the rainwater tank to the water closet, water heater or laundry cold water outlets. Stormwater connections, including from the roof to the rainwater tank, and from rainwater tank overflow, are regulated by the local council or relevant authority under the *Development Act 1993*.

SA 2.2.3 Rainwater tank overflow

The *rainwater tank* must be fitted with an overflow device that disposes of overflow from the *rainwater tank* in accordance with:

- (a) any specific requirements of the relevant authority; and
- (b) Part 3.1.3 of the Building Code of Australia.

SA 2.2.4 Rainwater tank water quality

The inlet and overflow of the *rainwater tank* must be fitted with mosquito proof, non-degradable screens.

Explanatory information:

Clause SA 2.2.4 requires the fitting of mosquito proof, non-degradable screens to the *rainwater tank*. The quality of the water stored in the *rainwater tank* should be managed in accordance with the Department of Health publication 'Guidance on the use of rainwater tanks'.

SA 2.2.5 Rainwater tank stands

Where a *rainwater tank* is supported on a stand or other structure, the supporting structure must comply with Clause 3.0.2.

SA 3 Wet areas

SA 3.1 Performance provisions

Performance Requirements

Floors in bathrooms, or rooms containing a shower or a sanitary fixture, must be installed in a manner that will prevent accumulation of water on the surface which could create unhealthy or hazardous conditions.

SA 3.2 Acceptable construction practice

SA 3.2.1 Application

Performance Requirement SA3.1 is satisfied for *wet areas* if they comply with SA 3.2.2.

SA 3.2.2 Provision of floor wastes

- (a) The floor of a *wet area* containing a *vessel* must be graded to a floor waste to permit drainage of water.
- (b) A floor need not be graded to a floor waste as *required* by (a) if—
 - (i) all *vessels* are provided with in-built overflow protection or have a permanent open trapped connection to the plumbing and drainage system (such as a WC pan); or
 - (ii) the floor waste is provided solely for the connection of plumbing fixtures.
- (c) A floor of a *wet area* that is graded without ponding to a floor waste within the *shower area* will satisfy (a).
- (d) The fall of the floor surface graded to a floor waste in accordance with (a) or (c) must be—
 - (i) between 1:60 and 1:80 in the *shower area*; and
 - (ii) between 1:80 and 1:100 in other areas.

SA 4 Swimming pool signage

SA 4.1 Performance provisions

Performance requirements

A swimming pool must have prominent and visible signage that assists persons to provide first aid and to perform cardiopulmonary resuscitation on young children.

SA 4.2 Acceptable construction practice

SA 4.2.1 Application

A swimming pool must have prominent and visible signage that assists persons to provide first aid and to perform cardiopulmonary resuscitation on young children.

SA 4.2.2 Signage

A first aid and cardiopulmonary resuscitation sign must:

- (i) Be attached to the safety barrier of the swimming pool or be displayed near the swimming pool; and
- (ii) Be at least 300 mm by 300 mm in size; and
- (iii) Be made of durable and weatherproof material; and
- (iv) Show information about the procedures for providing first aid, including performing cardiopulmonary resuscitation.

South Australia additions

Safe movement and access

SA 4 * * * * *

This clause has been deliberately left blank.

SA 5 Access for people with a disability

Limitation:

SA 5 applies to Class 1 buildings in developments of 20 or more dwellings.

SA 5.1 Performance provisions

Objective

Provide, as far as is reasonable, people with safe, equitable and dignified access to a degree necessary to—

- (a) buildings; and
- (b) the services and facilities within.

Functional Statements

A building to a degree necessary is, as far as is reasonable, to provide safe, equitable and dignified access for people to the services and facilities within.

Performance Requirements

Buildings and immediate surrounds must have appropriate features to a degree necessary to enable people with a disability to safely and equitably—

- (a) negotiate the route from the road boundary to and within the building using a wheelchair; and
- (b) have access to spaces within the building, including facilities *required* under P2.4.3.

SA 5.2 Acceptable construction practice

SA 5.2.1 Application

Compliance with the acceptable construction practice provisions of Part SA 5.2 for access for people with a disability satisfies *Performance Requirement SA 5.1*.

SA Part 5.2 applies to certain Class 1 buildings where access is *required* under Clause SA 5.2.2.

SA 5.2.2 Access to buildings

In developments consisting of 20 or more dwellings, access must be provided to and within one dwelling or 5% of the total number of dwellings, whichever is the greater.

SA 5.2.3 Parts of buildings to be accessible

- (a) Access for people with a disability must be provided from the entrance doorway to areas normally used by the occupants. A path of travel providing *required* access must not include a stairway or other impediment which would prevent a person in a wheelchair using it.
- (b) Access, finishes and fittings must comply with the provisions of AS 1428.1.
- (c) In every Class 1 building to which access for people with a disability is *required*, one closet pan and washbasin and one shower must be provided for use by people with a disability.

SA 6 Access for inspection and maintenance

SA 6.1 Performance provisions

Objective

The Objective is to safeguard people from injury and illness resulting from the creation of hazardous spaces between buildings.

Functional Statements

The space between buildings must not allow hazardous conditions to arise due to accumulation of rubbish that cannot be readily removed.

Performance Requirements

The space between buildings must be sufficient to allow access for inspection and maintenance to avoid hazardous conditions arising due to accumulation of rubbish that could—

- (a) bridge termite barriers; or
- (b) harbour vermin; or
- (c) create a fire hazard.

SA 6.2 Acceptable construction practice**SA 6.2.1 Application**

Compliance with the acceptable construction provision of SA 6.2 for acceptable separation between buildings for Class 1 and 10 buildings satisfies *Performance Requirement SA 6.1*.

SA 6.2.2 Minimum separation between buildings

Unless the space between external columns is not infilled, every part of an *external wall* of a building must be not less than 600 mm from—

- (a) any boundary of the allotment, unless that wall is on or abutting that boundary; or
- (b) the *external wall* of any other building on the same allotment, unless the two buildings are abutting.

South Australia variations

Application of South Australian variations

This Appendix contains variations for application in South Australia as follows:

SA Schedule 3 Definitions

Add the definition of *brush fence* as follows:

Brush fence means a fence or gate that is primarily constructed of Broombrush (*Melaleuca Uncinata*).

Insert in Table 1 of Schedule 4 the following:

SA Schedule 4 Schedule of referenced documents

SA Table 1 Schedule of referenced documents

No.	Date	Title	Volume Two
SA 3.12.0.1(a)	2012	South Australian Minister's Specification — Heating and cooling loads for elevated buildings with a lightweight framed flooring system and transportable buildings	SA 3.12.0.1(a)
AS 1428 Part 1	2001	Design for access and mobility— General requirements for access — New building work	SA 5.2.3
AS 1530.8 Part 1	2007	Tests on elements of construction for buildings exposed to simulated bushfire attack — Radiant heat and small flaming sources	SA 3.7.4.3
AS 1530.8 Part 2	2007	Tests on elements of construction for buildings exposed to simulated bushfire attack — Large flaming sources	SA 3.7.4.3
enHealth Council, Department of Health and Ageing	2004	Guidance on the use of rainwater tanks	SA 2.2.4

Footnote: Other legislation affecting buildings

In addition to any applicable provisions of the Development Act 1993, the Development Regulations 2008, The Planning, Development and Infrastructure Act 2016 and its associated regulations and this Code, there are a number of other legislative technical requirements affecting the design, construction and/or performance of buildings that practitioners may need to be aware of, including, but not necessarily limited to, the following list. Additional legislative instruments such as regulations, codes and standards may exist under the legislation listed.

1. Accommodation

Administering agency

Department for Human Services

Relevant legislation

Supported Residential Facilities Act 1992

Supported Residential Facilities Regulations 2009

2. Asbestos Removal

Administering agency

SafeWork SA, Department of the Premier and Cabinet

Relevant legislation

Work, Health and Safety Act 2012

Work, Health and Safety Regulations 2012

3. Crown Land

Administering agency

Department for Environment and Water

Relevant legislation

Crown Land Management Act 2009

Crown Land Management Regulations 2010

4. Electrical Installations

Administering agency

Office of the Technical Regulator, Department for Industry and Skills

Relevant legislation

Electricity Act 1996

Electricity (General) Regulations 2012

Energy Products Act 2012

Energy Products (Safety and Efficiency) Regulations 2012

5. Encroachments

Administering agency

Attorney-General's Department

Relevant legislation

Encroachments Act 1944

6. Fences

Administering agency

Attorney-General's Department

Relevant legislation

Fences Act 1975

Fences Regulations 2018

7. Fire Prevention in Existing Buildings

Administering agency

Department of Planning, Transport and Infrastructure

Relevant legislation

Development Act 1993

Development Regulations 2008

Administering agency

SA Fire and Emergency Services Commission

Relevant legislation

Fire and Emergency Services Act 2005

Fire and Emergency Services Regulations 2005

8. Gas Installations

Administering agency

Office of the Technical Regulator, Department for Industry and Skills

Relevant legislation

Gas Act 1997

Gas Regulations 2012

Energy Products Act 2012

Energy Products (Safety and Efficiency) Act 2000

Energy Products (Safety and Efficiency) Regulations 2012

9. Historic Buildings

Administering agency

Department for Environment and Water

Relevant legislation

Heritage Places Act 1993

Heritage Places Regulations 2005

10. Housing

Administering agency

Department of Human Services

Relevant legislation

Housing Improvement Act 2016

Housing Improvement Regulations 2017

11. Lift Installations

Administering agency

Safework SA, Department of the Premier and Cabinet

Relevant legislation

Work, Health and Safety Act 2012

Work, Health and Safety Regulations 2012

12. Occupational Health and Safety

Administering agency

SafeWork SA, Department of the Premier and Cabinet

Relevant legislation

Work, Health and Safety Act 2012

Work, Health and Safety Regulations 2012

13. Sanitary Plumbing, Water Supply and Sewerage

Administering agency

Office of the Technical Regulator, Department for Industry and Skills

Relevant legislation

Water Industry Act 2012

Water Industry Regulations 2012

14. Septic Tank and Grey Water Installations

Administering agency

Department for Health and Wellbeing

Relevant legislation

South Australian Public Health Act 2011

South Australian Public Health (Wastewater) Regulations 2013

15. Subdivision of Property

Administering agency

Land Services Group, Department of Planning, Transport and Infrastructure

Relevant legislation

Community Titles Act 1996

Community Titles Regulations 2011

Real Property Act 1886

Real Property Regulations 2009

Strata Titles Act 1988

Strata Titles Regulations 2018

16. Waste Management and Environment Protection

Administering agency

Environment Protection Authority

Relevant legislation

Environment Protection Act 1993

Environment Protection Regulations 2009

Tasmania

Tasmania additions

Tasmania additions

Tasmania variations

Footnote: Other legislation affecting buildings

Tasmania

Tasmania additions

Tas 1 * * * * *

Tasmania additions

Health and amenity

Tas 2 Swimming pool water recirculation and filtration

Tasmania variations

Tas Schedule 3 Definitions

Tas Schedule 4 Schedule of referenced documents

Footnote: Other legislation affecting buildings

1. Administering Agency

Tasmania additions

Application of Tasmanian additions

This Appendix contains additional provisions for application in Tasmania as follows:

Fire safety

Tas 1 * * * * *

This clause has been deliberately left blank.

Tasmania additions

Health and amenity

Tas 2 Swimming pool water recirculation and filtration

Limitation:

Tas 2 does not apply to a *swimming pool* associated with a Class 1 building if the depth of water is less than 300 mm and the volume of the pool does not exceed 15 m³.

Tas 2.1 Performance provisions

Performance Requirements

Swimming pools must be provided with an adequate water recirculation, disinfection and filtration system which is suitable and safe to use.

Tas 2.2 Acceptable construction practice

Tas 2.2.1 Application

Compliance with the provisions of [Tas 2.2](#) for a *swimming pool* associated with a Class 1 building with a depth of water more than 300 mm and volume exceeding 15 m³ satisfies [Performance Requirement Tas 2.1](#).

Tas 2.2.2 Water recirculation and filtration system

A water recirculation, disinfection and filtration system in a *swimming pool* must provide for—

- (a) the inlet and outlet openings for the purpose of water recirculation to be so located that water movement is continuous from inlet to outlet; and
- (b) * * * * *
- (c) the recirculation of water to be so designed that the pool contents are recirculated not less than once—
 - (i) in 6 hours for an outdoor *swimming pool*; or
 - (ii) in 4 hours for an indoor *swimming pool*; and
- (d) the water filtration rates to not exceed 12 250 L/m² of sand filter bed per hour, or an equivalent rate in other filter media.

Tasmania variations

Application of Tasmanian variations

This Appendix contains variations for application in Tasmania as follows:

Insert in Table 1 of Schedule 4 the following:

Tas Schedule 3 Definitions

Add the definition of *Registered Testing Authority* as follows:

Registered Testing Authority means—

- (a) an organisation registered by the National Association of Testing Authorities (NATA) to test in the relevant field; or
- (b) an organisation outside Australia registered by an authority recognised by NATA through a mutual recognition agreement.

Tas Schedule 4 Schedule of referenced documents

Tas Table 1 Schedule of referenced documents

No.	Title	Volume Two
N/A	Condensation in Buildings Tasmanian Designers' Guide - Version 2	Tasmanian Note to Part 3.8.7

All referenced documents including legislation, codes, Australian Standards, guidelines and codes of practice are the version current at the time of the project documentation approval, unless noted otherwise.

Footnote: Other legislation affecting buildings

In addition to any applicable provisions of the Building Act and other legislative and regulatory instruments under that Act, such as regulations, codes (including this Code) and standards there may be a number of other legislative technical requirements, and regulatory instruments affecting the design, construction and/or performance of buildings of which practitioners may need to be aware. Additional legislative and regulatory instruments such as regulations, codes and standards may apply.

All referenced documents including legislation, codes, Australian Standards, guidelines and codes of practice are the version current at the time of the project documentation approval, unless noted otherwise.

1. Administering Agency

Department of Justice - Consumer, Building and Occupational Services

Relevant Legislation

Director's determinations and guidelines

Victoria

Victoria additions

Victoria variations

Footnote: Other legislation affecting buildings

Victoria

Victoria additions

Victoria variations

Vic Schedule 3 Definitions

Vic Schedule 4 Schedule of referenced documents

Footnote: Other legislation affecting buildings

1. Accommodation – Residential (Boarding Houses, Guest Houses, Hostels, Motels)
2. Alpine Resorts
3. Asbestos Removal
4. Crown Land
5. Electrical Installations
6. Fences - dividing
7. Fire Prevention in Existing Buildings
8. Gas Installations
9. Historic Buildings
10. Moveable Dwellings (in Caravan Parks)
11. Occupational Health and Safety
12. Planning Controls
13. Sanitary Plumbing, Water Supply and Sewerage
14. Septic Tank Installations
15. Subdivision of Buildings

Victoria additions

Victoria has no additions to the Housing Provisions.

Victoria variations

Application of Victorian variations

This Appendix contains variations for application in Victoria as follows:

Vic Schedule 3 Definitions

Substitute the definition of *flood hazard area* as follows:

Flood hazard area means the *site* (whether or not mapped) encompassing land in an area liable to flooding within the meaning of Regulation 153 of the Building Regulations 2018.

Substitute the definition of *freeboard* as follows:

Freeboard means the minimum height of the level of the lowest floor of a building above the *defined flood level*, regulated by the relevant planning scheme, or specified or otherwise determined by the relevant council under Regulation 153 of the Building Regulations 2018 (see [Figure 3](#)).

Vic Schedule 4 Schedule of referenced documents

Insert in Table 1 of Schedule 4 the following:

Vic Table 1 Schedule of referenced documents

No.	Date	Title	Volume Two
N/A	2018	Plumbing Regulations	V2.6.1 , 3.12.0

Footnote: Other legislation affecting buildings

In addition to any applicable provisions of the Building Act 1993, Building Regulations 2018 and this Code, there are a number of other legislative technical requirements affecting the design, construction and/or performance of buildings that practitioners may need to be aware of, including, but not necessarily limited to, the following list. Additional legislative instruments such as regulations, codes and standards may exist under the legislation listed.

1. Accommodation – Residential (Boarding Houses, Guest Houses, Hostels, Motels)**Administering Agency**

Department of Health and Human Services

Consumer Affairs Victoria

Municipal council

Relevant Legislation

Public Health and Wellbeing Act 2008

Public Health and Wellbeing Regulations 2009

Residential Tenancies Act 1997

Residential Tenancies (Rooming House Standards) Regulations 2012

2. Alpine Resorts**Administering Agency**

Department of Environment, Land, Water and Planning

Alpine Resorts Management Boards

Relevant Legislation

Alpine Resorts (Management) Act 1997

3. Asbestos Removal**Administering Agency**

Victorian WorkCover Authority

Environment Protection Authority

Relevant Legislation

Occupational Health and Safety Act 2004

Environment Protection Act 1970

4. Crown Land**Administering Agency**

Department of Environment, Land, Water and Planning

Crown Land committees of management

Relevant Legislation

Crown Land (Reserves) Act 1978

5. Electrical Installations**Administering Agency**

Energy Safe Victoria

Electrical transmission and distribution companies

Relevant Legislation

Electricity Industry Act 2000

Electricity Industry (Residual Provisions) Act 1993

Electricity Safety Act 1998

State Electricity Commission Act 1958
Electricity Safety (Installations) Regulations 2009
Standards Australia Wiring Rules, AS/NZS 3000/3013

6. Fences - dividing

Administering Agency

Department of Justice and Regulation
Dispute Settlement Centre of Victoria

Relevant Legislation

Fences Act 1968

7. Fire Prevention in Existing Buildings

Administering Agency

Municipal council

Relevant Legislation

Building Act 1993
Building Regulations 2018

8. Gas Installations

Administering Agency

Energy Safe Victoria

Relevant Legislation

Gas Industry Act 2001
Gas Safety Act 1997
Gas Safety (Gas Installation) Regulations 2008
AS/NZS 5601 Gas Installations

9. Historic Buildings

Administering Agency

Department of Environment, Land, Water and Planning
Executive Director under the Heritage Act 2017

Relevant Legislation

Heritage Act 2017

10. Moveable Dwellings (in Caravan Parks)

Administering Agency

Department of Environment, Land, Water and Planning
Municipal council

Relevant Legislation

Residential Tenancies Act 1997
Residential Tenancies (Caravan Parks and Moveable Dwellings Registration and Standards) Regulations 2010

11. Occupational Health and Safety

Administering Agency

Victorian WorkCover Authority

Relevant Legislation

Occupational Health and Safety Act 2004
Occupational Health and Safety Regulations 2017

Codes of practice published by the Victorian WorkCover Authority

12. Planning Controls

Administering Agency

Department of Environment, Land, Water and Planning

Municipal council

Relevant Legislation

Planning and Environment Act 1987

Planning schemes

13. Sanitary Plumbing, Water Supply and Sewerage

Administering Agency

Victorian Building Authority

Relevant Legislation

Building Act 1993

Plumbing Regulations 2018

Plumbing Code of Australia

AS/NZS 3500 Plumbing and Drainage

14 Septic Tank Installations

Administering Agency

Environment Protection Authority

Municipal council

Relevant Legislation

Environment Protection Act 1970

Guidelines For Environmental Management: Code of Practice-Onsite wastewater management

15. Subdivision of Buildings

Administering Agency

Department of Environment, Land, Water and Planning

Municipal council

Relevant Legislation

Subdivision Act 1988

Western Australia

Western Australia additions

Western Australia variations

Footnote: Other legislation affecting buildings

Western Australia

Western Australia additions

Heated water systems

Water use

Western Australia variations

WA Schedule 3 Definitions

WA Schedule 4 Schedule of referenced documents

Footnote: Other legislation affecting buildings

1. Building
2. Caravan Parks and Camping Grounds
3. Child Care
4. Fences
5. Health
6. Heritage
7. Housing
8. Land
9. Occupational Health and Safety
10. Planning Controls
11. Public Works

Western Australia additions

Application of Western Australia additions

This appendix contains additional provisions for application in Western Australia as follows:

Heated water systems

WA 1.1 * * * * *

This clause has deliberately been left blank.

WA 1.2 * * * * *

This clause has deliberately been left blank.

Water use

WA 2.2 Performance provisions

Objective

The Objective is to reduce water demand by using water efficiently and minimising water wastage.

Functional Statements

To reduce potable water demand, a building is to be capable of using *potable water* efficiently and preventing excessive loss of *potable water*.

Performance Requirements

(a) Water use efficiency

A building must have features that, to the degree necessary, facilitate the efficient use of *potable water* appropriate to—

- (i) the geographic location of the building; and
- (ii) the available *potable water* supply for the building; and
- (iii) the function and use of the building.

(b) Water loss prevention

A building, including any water holding structure, must have features that, to the degree necessary, prevent the excessive loss of *potable water* appropriate to—

- (i) the geographic location of the building; and
- (ii) the available *potable water* supply for the building; and
- (iii) the function and use of the building; and
- (iv) the effects of permanent features such as topography, structures and buildings.

(c) Heated water use efficiency

A building must have features that, to the degree necessary, facilitate the efficient use of heated water appropriate to—

- (i) the geographic location of the building; and
- (ii) the available heated water supply for the building; and
- (iii) the function and use of the building.

Application

The performance provisions of [WA 2.2](#) apply to Class 1 buildings, associated Class 10a buildings and *swimming pools*

associated with a Class 1 building.

A building's water use efficiency is satisfied by complying with [WA 2.3.1](#).

A building's water loss prevention is satisfied by complying with [WA 2.3.2](#).

A building's heated water use efficiency is satisfied by complying with [WA 2.3.3](#).

WA 2.3 Acceptable construction practice

WA 2.3.1 Water use efficiency

- (a) All tap fittings other than bath outlets and garden taps must be a minimum of 4 stars [WELS](#) rated.
- (b) All showerheads must be a minimum of 3 stars [WELS](#) rated.
- (c) All sanitary flushing systems must be a minimum of 4 stars [WELS](#) rated dual flush.

WA 2.3.2 Swimming pool covers and blankets

An outdoor private [swimming pool](#) or spa associated with a Class 1 building must be supplied with a cover, blanket or the like that—

- (a) is designed to reduce water evaporation; and
- (b) is accredited under the Smart Approved Watermark Scheme governed by the Australian Water Association, the Irrigation Association of Australia, the Nursery and Garden Industry Australia and the Water Services Association of Australia.

WA 2.3.3 Heated water use efficiency

All internal heated water outlets (such as taps, showers and washing machine water supply fittings) must be connected to a heated water system or a re-circulating heated water system with pipes installed and insulated in accordance with AS/NZS 3500: Plumbing and Drainage, Part 4 Heated Water Services. The pipe from the heated water system or re-circulating heated water system to the furthest heated water outlet must not be more than 20 m in length or 2 litres of internal volume.

Western Australia variations

Application of Western Australian variations

This Appendix contains variations for application in Western Australia as follows:

WA Schedule 3 Definitions

Insert definition for *potable water* as follows:

Potable water means water intended for human consumption supplied by a water services provider.

Insert definition for *WELS* as follows:

WELS has the meaning given in the Water Efficiency Labelling and Standards Act 2005 of the Commonwealth section 7.

WA Schedule 4 Schedule of referenced documents

Insert in Table 1 of Schedule 4 the following:

WA Table 1 Schedule of referenced documents

No.	Date	Title	Volume Two
AS/NZS 3500.4	2018	Plumbing and drainage - Heated water services, Amdt 1	WA 2.3.3

Footnote: Other legislation affecting buildings

In addition to any applicable provisions of the Building Act 2011, Building Regulations 2012 and this Code, there are a number of other legislative technical requirements affecting the design, construction and/or performance of buildings that practitioners may need to be aware of, including, but not necessarily limited to, the following list. Additional legislative instruments such as regulations, codes and standards may exist under the legislation listed.

1. Building

Administering Agency

Department of Mines, Industry Regulation and Safety

Relevant Legislation

Building Services (Complaint Resolution and Administration) Act 2011

Building Services (Complaint Resolution and Administration) Regulations 2011

Building Service (Registration) Act 2011

Building Service (Registration) Regulations 2011

2. Caravan Parks and Camping Grounds

Administering Agency

Department of Local Government, Sport and Cultural Industries

Relevant Legislation

Caravan Park and Camping Grounds Act 1995

Caravan Park and Camping Grounds Regulations 1997

3. Child Care

Administering Agency

Department of Communities

Relevant Legislation

Child Care Services Act 2007

Child Care Services Regulations 2007

Child Care Services (Child Care) Regulations 2006

4. Fences

Administering Agency

Department of Mines, Industry Regulation and Safety

Relevant Legislation

Dividing Fences Act 1961

5. Health

Administering Agency

Department of Health

Relevant Legislation

Health Act (Miscellaneous Provisions) 1911

Health Act (Laundries & Bathrooms) Regulations

Health (Air Handling and Water Systems) Regulations 1994

Health (Asbestos) Regulations 1992

Health (Aquatic Facilities) Regulations 2007

Health (Construction Work) Regulations 1973

Construction Camp Regulations

Health (Public Buildings) Regulations 1992

Health (Treatment of Sewage and Disposal of Effluent and Liquid Waste) Regulations 1974

Health (Rottnest Island) By-laws 1989

Sewerage (Lighting, Ventilation and Construction) Regulations 1971

Health Local Laws where adopted by Local Government

6. Heritage

Administering Agency

Heritage Council of Western Australia

Relevant Legislation

Heritage of Western Australia Act 1990

Heritage of Western Australia Regulations 1991

7. Housing

Administering Agency

Department of Communities

Relevant Legislation

Housing Act 1980

8. Land

Administering Agency

Western Australian Land Information Authority

Relevant Legislation

Strata Titles Act 1985

9. Occupational Health and Safety

Administering Agency

Department of Mines, Industry Regulation and Safety

Relevant Legislation

Occupational Safety and Health Act 1984

10. Planning Controls

Administering Agency

Department of Planning, Land and Heritage

Relevant Legislation

Planning and Development Act 2005

Planning and Development (Consequential and Transitional Provisions) Act 2005

11. Public Works

Administering Agency

Department of Finance, Building Management and Works

Relevant Legislation

Public Works Act 1902

Abbreviations and Symbols

Schedule 2 Abbreviations and symbols

Schedule 2 Abbreviations and Symbols

Schedule 2 Abbreviations and symbols

Abbreviations and Symbols

Schedule 2 Abbreviations and symbols

Abbreviations and symbols used in the NCC include:

Abbreviations

Abbreviation	Definition
ABCB	Australian Building Codes Board
AC	Alternating Current
AS	Australian Standard
ASET	Available Safe Egress Time
ASTM	American Society for Testing and Materials
BCA	Building Code of Australia
BE	Fire blocks evacuation route
CCT	Correlated Colour Temperature
CF	Challenging fire
CHF	Critical Heat Flux
CRF	Critical Radiant Flux
CRI	Colour Rendering Index
CS	Fire starts in a concealed space
C_{SHGC}	Constant for solar heat gain
CSIRO	Commonwealth Scientific and Industrial Research Organisation
C_U	Constant for conductance
DC	Direct Current
FED	Fractional Effective Dose
FI	Fire brigade intervention
FRL	Fire Resistance Level
GRP	Glass fibre reinforced polyester
HRR	Heat Release Rate
HS	Horizontal fire spread
IS	Rapid fire spread involving internal surface linings
ISO	International Organisation for Standardisation
LED	Light-Emitting Diode
MEPS	Minimum Energy Performance Standards
NABERS	National Australian Built Environment Rating System
NATA	National Association of Testing Authorities
NatHERS	Nationwide House Energy Rating Scheme
NCC	National Construction Code
PBDB	Performance-based design brief
PCA	Plumbing Code of Australia
PMV	Predicted Mean Vote
ppm	Parts per million
PVC	Polyvinyl chloride
RC	Robustness check
RSET	Required Safe Egress Time
R_w	Weighted sound reduction index
SF	Smouldering fire
SHGC	Solar Heat Gain Coefficient
SS	Structural stability and other property
STC	Sound Transmission Class

Abbreviations and Symbols

Abbreviation	Definition
UF	Unexpected catastrophic failure
UPVC	Unplasticized polyvinyl chloride
UT	Fire in normally unoccupied room threatening occupants of other rooms
U-Value	Thermal transmittance
VS	Vertical fire spread involving external cladding or external openings

Symbols

Symbol	Definition
°	degree(s)
°C	degree(s) Celsius
°CDB	degree(s) Celsius Dry Bulb
°CWB	degree(s) Celsius Wet Bulb
-e/MJ	equivalent per Megajoule(s)
µm	micrometre
dB(A)	decibels "A" scale weighting network
J	Joule(s)
J/kg.K	Joules per kilogram degree Kelvin
J/s.m ²	Joules per second square metre
K	Kelvin(s)
kg	kilogram(s)
kg/m	kilogram(s) per metre
kg/m ²	kilogram(s) per square metre
kg/m ³	kilogram(s) per cubic metre
kJ/m ² .hour	kilojoules per square metre hour
km	kilometre(s)
kPa	kilopascal(s)
kW/m ²	kilowatt(s) per square metre
kW _{heating}	kilowatt(s) of heating
kWr	kilowatt(s) of refrigeration
L	litre(s)
L/min	litre(s) per minute
L/s	litre(s) per second
L/s.m ²	litre(s) per second square metre
Lumens/W	Lumens per Watt
lx	lux
m	metre(s)
m/s	metre(s) per second
m ²	square metre(s)
m ² .K/W	square metre Kelvin(s) per Watt
m ³	cubic metre(s)
m ³ /hour	cubic metre(s) per hour
m ³ /s	cubic metre(s) per second
mcd/m ²	millicandelas per square metre
min	minute(s)
MJ/hour	Megajoules per hour
MJ/m ² .annum	Megajoules per square metre annum
mm	millimetre(s)
mm ²	square millimetre(s)

Abbreviations and Symbols

Symbol	Definition
MW	megawatt(s)
N	newton(s)
Pa	pascal(s)
Pa/m	pascal(s) per metre
s	second(s)
V	Volt(s)
W	Watt(s)
$W_{\text{input power}}$	Watts of input power
$W_r/W_{\text{input power}}$	Watts of thermal refrigeration per watt of input power
W/kW_{rej}	Watts per kilowatt of heat rejected
W/m.K	Watts per metre degree Kelvin
W/m ²	Watts per square metre
°south	degree south
%	percent
>	greater than
<	less than
≤	less than or equal to
≥	equal to or more than

Definitions

Schedule 3 Definitions

Schedule 3 Definitions

Schedule 3 Definitions

Definitions

Schedule 3 Definitions

Definitions

Note: States and Territories may vary or add to the definitions contained in [Schedule 3](#) at the relevant State or Territory Appendix.

In the NCC unless the contrary intention appears—

Accessible means having features to enable use by people with a disability.

Accessway means a continuous [accessible](#) path of travel (as defined in AS 1428.1) to, into or within a building.

Accredited Testing Laboratory means—

- (a) an organisation accredited by the National Association of Testing Authorities (NATA) to undertake the relevant tests; or
- (b) an organisation outside Australia accredited to undertake the relevant tests by an authority recognised by NATA through a mutual recognition agreement; or
- (c) an organisation recognised as being an [Accredited Testing Laboratory](#) under legislation at the time the test was undertaken.

Activity support level means the degree to which occupants can undertake activities with respect to the likely [activity traits](#) and [occupant traits](#).

Explanatory information:

This term is used to articulate whether the height of a room or space is sufficient and by what degree. This is achieved by having regard to the room or space's intended use by occupants, through consideration of the defined terms '[activity traits](#)' and '[occupant traits](#)'.

Activity traits, for the purposes of Volume One, means the features of the activities that will be undertaken in a [habitable room](#) or space.

Activity traits, for the purposes of Volume Two, means the features of the activities that will be undertaken in a room or space.

Explanatory information:

This term is used to describe the characteristics of the activities that will be undertaken in a room or space.

For example, the activities likely to be undertaken in a bedroom, and the associated features are—

- sleeping — a person laying horizontally; and
- resting — a person laying horizontally or sitting upright on the bed; and
- leisure activities, such as reading a book — a person sitting upright on the bed, with enough space to stretch their arms vertically; and
- dressing/changing clothes — a person standing with enough space to stretch their arms vertically.

Administering body means the body responsible for administering the [WaterMark Certification Scheme](#).

Aged care building means a Class 9c building for residential accommodation of aged persons who, due to varying degrees of incapacity associated with the ageing process, are provided with [personal care services](#) and 24 hour staff assistance to evacuate the building during an emergency.

Air-conditioning, for the purposes of [Section J](#) of Volume One, means a [service](#) that actively cools or heats the air within a space, but does not include a [service](#) that directly

- (a) cools or heats cold or hot rooms; or
- (b) maintains specialised conditions for equipment or processes, where this is the main purpose of the [service](#).

Alarm zone, for the purposes of [Specification E2.2d](#) of Volume One, means an area of a building protected by one or more smoke alarms connected to one alarm circuit.

Alpine area means an area given in [Figure 1](#) and in [Table 1](#) for specific locations, and is—

- (a) likely to be subject to significant snowfalls; and
- (b) in New South Wales, A.C.T. or Victoria more than 1200 m above the Australian Height Datum; and
- (c) in Tasmania more than 900 m above the Australian Height Datum.

Definitions

Figure 1 Alpine areas

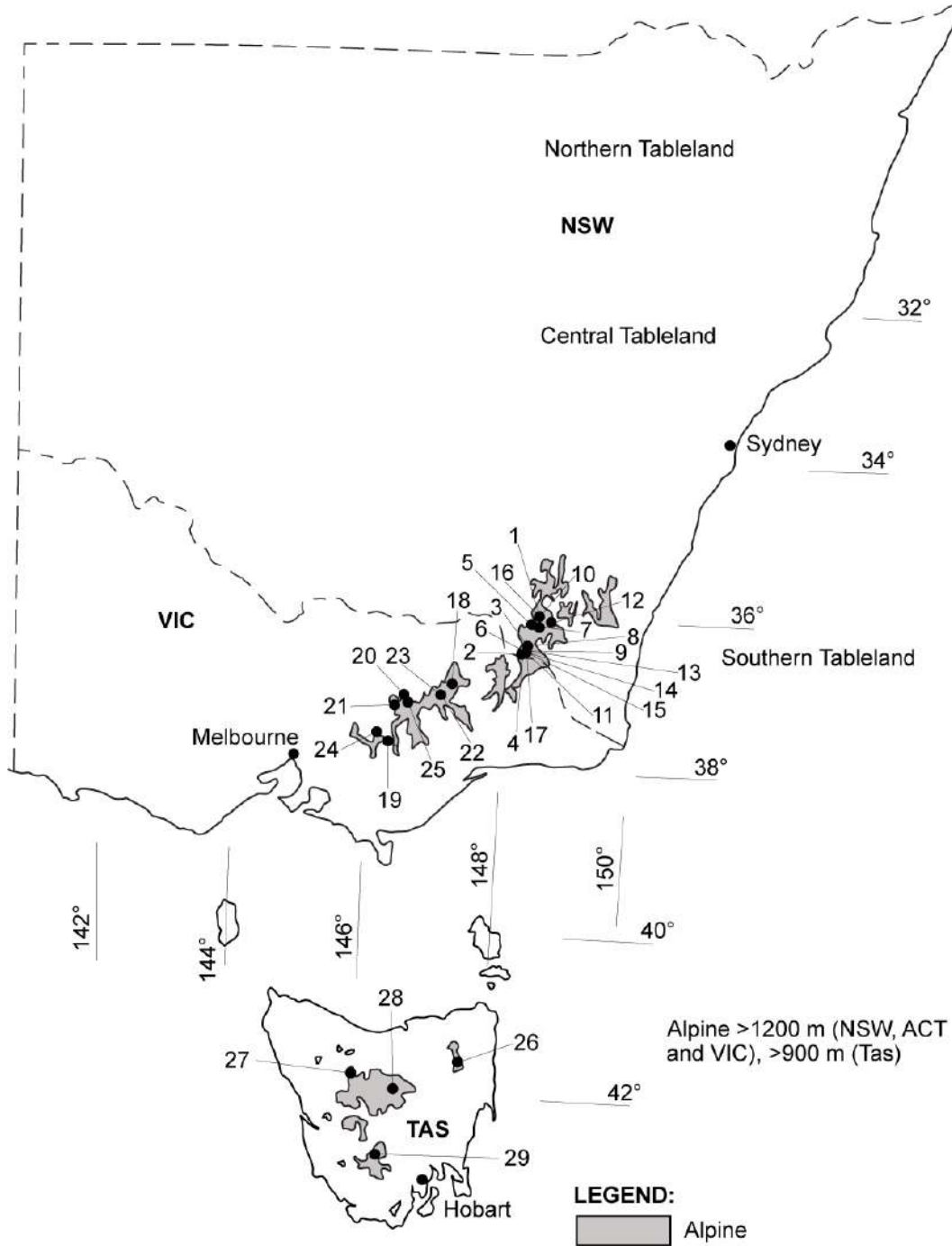

Note:

This map is approximate only and altitude above Australian Height Datum must be used to determine whether the building falls into an *alpine area* region.

Table 1 Alpine areas where snow loads are significant

Location	Map identifier
Kiandra (NSW)	1
Mount Kosciuszko (NSW)	2
Perisher Valley (NSW)	3
Thredbo (NSW)	4
Cabramurra (NSW)	5
Charlotte Pass Village (NSW)	6
Diggers Creek (NSW)	7

Definitions

Location	Map identifier
Guthega Village (NSW)	8
Mount Blue Cow (NSW)	9
Mount Selwyn (NSW)	10
Perisher Range (NSW)	11
Rules Point (NSW)	12
Sawpit Creek (NSW)	13
Smiggin Holes (NSW)	14
Smiggin Range (NSW)	15
Three Mile Dam (NSW)	16
Wilson's Valley (NSW)	17
Falls Creek (Vic.), including Summit Area, Sun Valley and Village Bowl	18
Mount Baw Baw (Vic.)	19
Mount Buffalo (Vic.), including Chalet, Dingo Dell and Tatra	20
Mount Buller (Vic.), including Baldy and Village	21
Mount Hotham (Vic.), including Davenport and Village Centre	22
Dinner Plain (Vic.)	23
Lake Mountain (Vic.)	24
Mount Stirling (Vic.)	25
Ben Lomond Ski Field (Tas.)	26
Cradle Valley (Tas.)	27
Great Lake Area (Tas.)	28
Mount Field Ski Field (Tas.)	29

Explanatory information:

Alpine areas are located in New South Wales, Victoria and Tasmania.

Alpine areas are areas 1200 m or more above Australian Height Datum (AHD) for New South Wales, Australian Capital Territory and Victoria, and 900 m or more above AHD for Tasmania, as shown in [Figure 1](#).

Alpine areas are considered to receive significant snowfalls (snowfalls that result in an average snow accumulation on the ground of 175 mm or greater). Regions in New South Wales, the Australian Capital Territory and Victoria between 600–1200 m AHD are considered to be sub-*alpine areas* and may receive significant snowfalls, however unlike *alpine areas* the snow is unlikely to accumulate.

It is recommended that the *appropriate authority* be consulted to determine whether the building is located in an *alpine area*. AS/NZS 1170.3 also contains further detail in the identification of *alpine areas* and the altitude of the alpine regions of Australia.

In the Australian Capital Territory, Canberra is not designated as an *alpine area* as snow loads are not considered significant.

Alteration, in relation to a building, includes an addition or extension to a building.

Amenity means an attribute which contributes to the health, physical independence, comfort and well-being of people.

Ancillary element means an element that is secondary to and not an integral part of another element to which it is attached.

Annual greenhouse gas emissions means the theoretical amount of greenhouse gas emissions attributable to the energy used annually by a building's *services*, excluding kitchen exhaust and the like.

Appropriate authority means the relevant authority with the statutory responsibility to determine the particular matter.

State and Territory variations

For Volume One see ([NSW, Appropriate authority](#))

For Volume Two see ([NSW, Appropriate authority](#))

Appropriate Authority, for the purposes of [Schedule 7](#), means the relevant authority with the statutory responsibility to determine the particular matter satisfies the relevant *Performance Requirement*.

Explanatory information:

Definitions

The *Appropriate Authority* is typically the building surveyor or building certifier charged with the statutory responsibility to determine building compliance and issue the building permit / approval and occupancy certificate / approval.

Appropriately qualified person means a person recognised by the *appropriate authority* as having qualifications and/or experience in the relevant discipline in question.

Approved disposal system means a system for the disposal of sewage, sullage or stormwater approved by an authority having jurisdiction.

Articulated masonry means masonry construction in which special provisions have been made for movement by articulation.

Assembly building means a building where people may assemble for—

- (a) civic, theatrical, social, political or religious purposes including a library, theatre, public hall or place of worship; or
- (b) educational purposes in a *school*, *early childhood centre*, preschool, or the like; or
- (c) entertainment, recreational or sporting purposes including—
 - (i) a discotheque, nightclub or a bar area of a hotel or motel providing live entertainment or containing a dance floor; or
 - (ii) a cinema; or
 - (iii) a sports stadium, sporting or other club; or
- (d) transit purposes including a bus station, railway station, airport or ferry terminal.

State and Territory variation

For Volume One see (*NSW, Assembly building*) and (*SA, Assembly building*)

Assessment Method means a method that can be used for determining that a *Performance Solution* or *Deemed-to-Satisfy Solution* complies with the *Performance Requirements*.

Atrium means a space within a building that connects 2 or more *storeys* and—

- (a) is enclosed at the top by a floor or roof (including a glazed roof structure); and
- (b) includes any adjacent part of the building not separated by an appropriate barrier to fire; but
- (c) does not include a stairwell, rampwell or the space within a *shaft*; and
- (d) for the purposes of (a) a space is considered enclosed if the area of the enclosing floor or roof is greater than 50% of the area of the space, measured in plan, of any of the *storeys* connected by the space.

Atrium well means a space in an *atrium* bounded by the perimeter of the openings in the floors or by the perimeter of the floors and the *external walls*.

Automatic means designed to operate when activated by a heat, smoke or fire sensing device.

Available safe egress time (ASET) means the time between ignition of a fire and the onset of untenable conditions in a specific part of a building. This is the calculated interval between the time of ignition of a fire and the time at which conditions become such that the occupant is unable to take effective action to escape to a place of safety.

Average daylight factor means the ratio of the illumination level within a room provided by daylight to the level of daylight outside the building during overcast conditions.

Average recurrence interval, applied to rainfall, means the expected or average interval between exceedances for a 5 minute duration rainfall intensity.

Average specific extinction area means the *average specific extinction area* for smoke as determined by AS 5637.1.

Backflow prevention device means an air gap, break tank or mechanical device that is designed to prevent the unplanned reversal of flow of water or *contaminants* into the water service or a *Network Utility Operator's* water supply.

Backpressure means a reversal of water flow caused by the downstream pressure becoming greater than the supply pressure.

Backsiphonage means a reversal of flow of water caused by negative pressure in the distributing pipes of a water service or supply.

Backstage means a space associated with, and adjacent to, a *stage* in a Class 9b building for scenery, props, equipment, dressing rooms, or the like.

Battery system means one or more chemical cells connected in series, parallel or a combination of the two for the purpose of electrical energy storage.

Blockage means an obstruction within a *drainage* system.

Definitions

Boiler means a vessel or an arrangement of vessels and interconnecting parts, wherein steam or other vapour is generated, or water or other liquid is heated at a pressure above that of the atmosphere, by the application of fire, the products of combustion, electrical power, or similar high temperature means, and—

- (a) includes superheaters, reheaters, economisers, *boiler* piping, supports, mountings, valves, gauges, fittings, controls, the *boiler* settings and directly associated equipment; but
- (b) excludes a fully flooded or pressurised system where water or other liquid is heated to a temperature lower than the normal atmospheric boiling temperature of the liquid.

Burnout means exposure to fire for a time that includes *fire growth*, full development, and decay in the absence of intervention or automatic suppression, beyond which the fire is no longer a threat to building elements intended to perform *loadbearing* or fire separation functions, or both.

Breaking surf means any area of salt water in which waves break on an average of at least 4 days per week but does not include white caps or choppy water.

Explanatory information:

Breaking surf normally occurs in areas exposed to the open sea. *Breaking surf* does not normally occur in sheltered areas, such as that which occurs around Port Phillip Bay, Sydney Harbour, Swan River, Derwent River and similar locations.

Carpark means a building that is used for the parking of motor vehicles but is neither a *private garage* nor used for the servicing of vehicles, other than washing, cleaning or polishing.

Cavity means a void between 2 leaves of masonry, or in masonry veneer construction, a void between a leaf of masonry and the supporting frame.

Cavity wall, for the purposes of [FV1.1](#) in Volume One and [V2.2.1](#) in Volume Two, means a wall that incorporates a drained cavity.

Certificate of Accreditation means a certificate issued by a State or Territory accreditation authority stating that the properties and performance of a building material or method of construction or design fulfil specific requirements of the BCA.

Certificate of Conformity means a certificate issued under the ABCB scheme for products and systems certification stating that the properties and performance of a building material or method of construction or design fulfil specific requirements of the NCC.

Certification body means a person or organisation operating in the field of material, product, form of construction or design certification that has been accredited by the Joint Accreditation System of Australia and New Zealand (JAZ-ANZ), and is accredited for a purpose other than as part of the CodeMark Australia Certification Scheme or *WaterMark Certification Scheme*.

Characteristic means the occupant data to be used in the modelling of access solutions which define how an occupant interacts with a building, i.e. occupant movement speeds, turning ability, reach capability, perception of luminance contrast and hearing threshold.

Clad frame means timber or metal frame construction with exterior timber or sheet wall cladding that is not sensitive to minor movement and includes substructure masonry walls up to 1.5 m high.

Climate zone means an area defined in [Figure 2](#) and in [Table 2](#) for specific locations, having energy efficiency provisions based on a range of similar climatic characteristics.

Definitions

Figure 2 Climate zones for thermal design



Notes:

1. This map can be viewed in enlargeable form on the ABCB website at www.abcb.gov.au.
2. A Zone 4 area in South Australia, other than a council area, at an altitude greater than 300 m above the Australian Height Datum is to be considered as Zone 5.

These areas have been defined in an enlarged format on the following maps produced by the Department of Planning, Transport and Infrastructure:

Adelaide Hills Council Climate Zone Map

Barossa Council Climate Zone Map

Regional Council of Goyder Climate Zone Map

These maps can be viewed on the Government of South Australia website at www.sa.gov.au.

3. Locations in *climate zone* 8 are in *alpine areas*.

Table 2 Climate zones for thermal design—Various locations

Location	Climate zone	Location	Climate zone	Location	Climate zone	Location	Climate zone
Australian Capital Territory				Canberra	7		
New South Wales							
Albury	4	Byron Bay	2	Lord Howe Island	2	Sydney West	6
Armidale	7	Cobar	4	Moree	4	Tamworth	4
Batemans Bay	6	Coffs Harbour	2	Newcastle	5	Thredbo	8
Bathurst	7	Dubbo	4	Nowra	6	Wagga Wagga	4
Bega	6	Goulburn	7	Orange	7	Williamtown	5
Bellingen Shire	7	Grafton	2	Perisher	8	Wollongong	5
Dorrigo Plateau	-			Smiggins			

Definitions

Location	Climate zone	Location	Climate zone	Location	Climate zone	Location	Climate zone
Bellingen Shire - Valley & seaboard	2	Griffith	4	Port Macquarie	5	Yass	6
Bourke	4	Ivanhoe	4	Sydney East	5		
Broken Hill	4	Lismore	2				
Northern Territory							
Alice Springs	3	Elliot	3	Renner Springs	3		
Darwin	1	Katherine	1	Tennant Creek	3		
Queensland							
Birdsville	3	Gladstone	2	Mount Isa	3		
Brisbane	2	Hervey Bay	2	Normanton	1	Townsville	1
Bundaberg	2	Hughenden	3	Rockhampton	2	Warwick	5
Cairns	1	Longreach	3	Roma	3	Weipa	1
Cooktown	1	Mackay	2	Southport	2		
Cunnamulla	3			Toowoomba	5		
South Australia							
Adelaide	5	Kingscote	6	Marree	4	Port Lincoln	5
Bordertown	6	Leigh Creek	5	Mount Gambier	6	Renmark	5
Ceduna	5	Lobethal	6	Murray Bridge	6	Tarcoola	4
Cook	4	Loxton	5	Oodnadatta	4	Victor Harbour	6
Elliston	5	Naracoorte	6	Port Augusta	4	Whyalla	4
Tasmania							
Burnie	7	Flinders Island	7	Launceston	7	Rossarden	7
Bicheno	7	Hobart	7	New Norfolk	7	Smithton	7
Deloraine	7	Huonville	7	Oatlands	7	St Marys	7
Devonport	7	King Island	7	Orford	7	Zeehan	7
Victoria							
Anglesea	6	Bright	7	Horsham	6	Swan Hill	4
Ararat	7	Colac	6	Melbourne	6	Traralgon	6
Bairnsdale	6	Dandenong	6	Mildura	4	Wangaratta	7
Ballarat	7	Echuca	4	Portland	6	Warrnambool	6
Benalla	6	Geelong	6	Sale	6	Wodonga	6
Bendigo	6	Hamilton	7	Shepparton	4		
Western Australia							
Albany	6	Cocos Island	1	Kalgoorlie-Boulder	4	Port Hedland	1
Balladonia	4	Derby	1	Karratha	1	Wagin	4
Broome	1	Esperance	5	Meekatharra	4	Wyndham	1
Bunbury	5	Exmouth	1	Northam	4		
Carnarvon	3	Geraldton	5	Pemberton	6		
Christmas Island	1	Halls Creek	3	Perth	5		

Combustible means—

- (a) applied to a material — *combustible* as determined by AS 1530.1; and
- (b) applied to construction or part of a building — constructed wholly or in part of *combustible* materials.

Common wall, for the purposes of Volume One, means a wall that is common to adjoining buildings.

Common wall, for the purposes of Volume Two, means a wall that is common to adjoining buildings other than Class 1 buildings.

Condensation means the formation of moisture on the surface of a building element or material as a result of moist air

Definitions

coming into contact with a surface which is at a lower temperature.

Conditioned space, for the purposes of Volume One, means a space within a building, including a ceiling or under-floor supply air plenum or return air plenum, where the environment is likely, by the intended use of the space, to have its temperature controlled by [air-conditioning](#).

Conditioned space, for the purposes of Volume Two, means a space within a building that is heated or cooled by the building's [domestic services](#), excluding a non-[habitable room](#) in which a heater with a capacity of not more than 1.2 kW or 4.3 MJ/hour is installed.

Containment protection means the installation of a [backflow prevention device](#) at the [point of connection](#) of a [Network Utility Operator's](#) water supply to a site.

Contaminant means any substance (including gases, liquids, solids or micro-organisms), energy (excluding noise) or heat, that either by itself or in combination with the same, similar or other substances, energy or heat, changes or is likely to change the physical, chemical or biological condition of water.

Construction activity actions means actions due to stacking of building materials or the use of equipment, including cranes and trucks, during construction or actions which may be induced by floor to floor propping.

Controlled fill means material that has been placed and compacted in layers with compaction equipment (such as a vibrating plate) within a defined moisture range to a defined density requirement.

Cooling load means the calculated amount of energy removed from the cooled spaces of the building annually by artificial means to maintain the desired temperatures in those spaces.

Critical radiant flux (CRF) means the critical heat flux at extinguishment (CHF in kW/m²) as determined by AS ISO 9239.1.

Cross-connection means any actual or potential connection between a water supply and any [contaminant](#).

Curtain wall means a non-[loadbearing external wall](#) that is not a [panel wall](#).

Damp-proof course (DPC) means a continuous layer of impervious material placed in a masonry wall or pier, or between a wall or pier and a floor, to prevent the upward or downward migration of water.

Deemed-to-Satisfy Provisions means provisions which are deemed to satisfy the [Performance Requirements](#).

Deemed-to-Satisfy Solution means a method of satisfying the [Deemed-to-Satisfy Provisions](#).

Defined flood event (DFE) means the flood event selected for the management of flood hazard for the location of specific development as determined by the [appropriate authority](#).

Defined flood level (DFL) means the flood level associated with a [defined flood event](#) relative to a specified datum (see [Figure 3](#)).

Figure 3 Identification of defined flood level, flood hazard level and freeboard

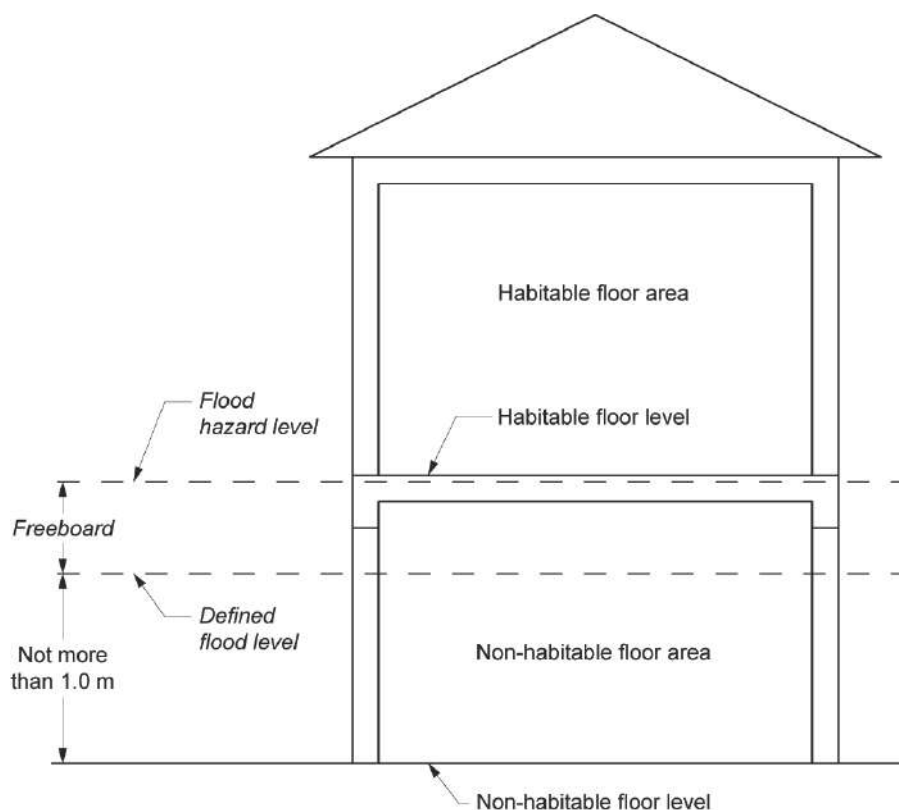

Design fire means the quantitative description of a representation of a fire within the [design scenario](#).

Definitions

Design scenario means the specific scenario of which the sequence of events is quantified and a *fire safety engineering* analysis is conducted against.

Design wind speed means the design gust wind speed for the area where the building is located, calculated in accordance with AS/NZS 1170.2 or AS 4055 (see [Table 3](#) for wind classes).

Table 3 Wind classes

Non-cyclonic Region A and B	Cyclonic Region C and D
N1, N2, N3	C1
N4, N5, N6 (these wind classes are covered by Volume Two Part 3.0 , Structural provisions).	C2, C3, C4 (these wind classes are covered by Volume Two Part 3.0 , Structural provisions).

Notes:

1. Wind classification map identifying wind regions is contained in Volume Two [Part 3.0](#) (see [Figure 3.0.1](#)).
2. Information on wind classes for particular areas may be available from the *appropriate authority*.
3. “N” = non-cyclonic winds and “C” = cyclonic winds.

Designated bushfire prone area means land which has been designated under a power of legislation as being subject, or likely to be subject, to bushfires.

State and Territory variations

For Volume One see ([NSW, Designated bushfire prone area](#))

For Volume Two see ([NSW, Designated bushfire prone area](#))

Detention centre means a building in which persons are securely detained by means of the built structure including a prison, remand centre, juvenile *detention centre*, holding cells or psychiatric *detention centre*.

Direct fix cladding wall, for the purposes of [FV1.1](#) in Volume One and [V2.2.1](#) in Volume Two, means a wall with cladding attached directly to the wall framing without the use of a drained cavity.

Discontinuous construction means the following:

- (a) A wall having a minimum 20 mm cavity between 2 separate leaves, and—
 - (i) for masonry, where wall ties are used to connect leaves, the ties are of the resilient type; and
 - (ii) for other than masonry, there is no mechanical linkage between the leaves, except at the periphery.
- (b) A staggered stud wall is not deemed to be *discontinuous construction*.

Display glazing means *glazing* used to display retail goods in a shop or showroom directly adjacent to a walkway or footpath, but not including that used in a café or restaurant.

Domestic services means the basic engineering systems that use energy or control the use of energy; and—

- (a) includes—
 - (i) heating, air-conditioning, mechanical ventilation and artificial lighting; and
 - (ii) pumps and heaters for *swimming pools* and spa pools; and
 - (iii) heated water systems; but
- (b) excludes cooking facilities and portable appliances.

Drainage means any sanitary *drainage*, liquid trade waste *drainage* or stormwater *drainage* system.

Drinking water means water intended primarily for human consumption but which has other domestic uses.

Explanatory Information:

See also the Australian Drinking Water Guidelines produced by the National Health and Medical Research Council.

Early childhood centre means any premises or part thereof providing or intending to provide a centre-based education and care service within the meaning of the Education and Care Services National Law Act 2010 (Vic), the Education and Care Services National Regulations and centre-based services that are licensed or approved under State and Territory children’s services law, but excludes education and care primarily provided to school aged children in outside school hours settings.

State and Territory variations

For Volume One see ([Tas, Early childhood centre](#)) and ([Vic, Early childhood centre](#))

Definitions

Effective height means the vertical distance between the floor of the lowest *storey* included in the calculation of *rise in storeys* and the floor of the topmost *storey* (excluding the topmost *storey* if it contains only heating, ventilating, lift or other equipment, water tanks or similar service units).

Electric passenger lift means a power-operated lift for raising or lowering people in a car in which the motion of the car is obtained from an electric motor mechanically coupled to the hoisting mechanism.

Electricity network substation means a building in which high voltage supply is converted or transformed and which is controlled by a licensed network service provider designated under a power of legislation.

Electrohydraulic passenger lift means a power-operated lift for raising or lowering people in a car in which the motion of the car is obtained from the action of liquid under pressure acting on a piston or ram, the pressure being generated by a pump driven by an individual electric motor.

Envelope, for the purposes of [Section J](#) in Volume One, means the parts of a building's *fabric* that separate a *conditioned space* or *habitable room* from—

- (a) the exterior of the building; or
- (b) a non-*conditioned space* including—
 - (i) the floor of a rooftop plant room, lift-machine room or the like; and
 - (ii) the floor above a *carpark* or warehouse; and
 - (iii) the *common wall* with a *carpark*, warehouse or the like.

Envelope, for the purposes of [Part 2.6](#) and [Part 3.12](#) in Volume Two, means the parts of a building's *fabric* that separate artificially heated or cooled spaces from—

- (a) the exterior of the building; or
- (b) other spaces that are not artificially heated or cooled.

Equivalent means equivalent to the level of health, safety and amenity provided by the *Deemed-to-Satisfy Provisions*.

Evacuation route means the continuous path of travel (including *exits*, *public corridors* and the like) from any part of a building, including within a *sole-occupancy unit* in a Class 2 or 3 building or Class 4 part, to a *safe place*.

Evacuation time means the time calculated from when the emergency starts for the occupants of the building to evacuate to a *safe place*.

Exit means—

- (a) any, or any combination of the following if they provide egress to a road or *open space*:
 - (i) An internal or external stairway.
 - (ii) A ramp.
 - (iii) A *fire-isolated passageway*.
 - (iv) A doorway opening to a road or *open space*.
- (b) A *horizontal exit* or a *fire-isolated passageway* leading to a *horizontal exit*.

Expert Judgement means the judgement of an expert who has the qualifications and experience to determine whether a *Performance Solution* or *Deemed-to-Satisfy Solution* complies with the *Performance Requirements*.

Explanatory Information:

Contemporary and relevant qualifications and/or experience are necessary to determine whether a *Performance Solution* complies with the *Performance Requirements*. The level of qualification and/or experience may differ depending on the complexity of the proposal and the requirements of the regulatory authority. Practitioners should seek advice from the authority having jurisdiction or *appropriate authority* for clarification as to what will be accepted.

State and Territory variation:

For Volume Three see ([Tas, Expert Judgement](#))

External wall, for the purposes of Volume One, means an outer wall of a building which is not a *common wall*.

External wall, for the purposes of Volume Two, means an outer wall of a building which is not a *separating wall*.

Extra-low voltage means a *voltage* not exceeding 50 V AC or 120 V ripple-free DC.

Fabric means the basic building structural elements and components of a building including the roof, ceilings, walls, glazing and floors.

Farming means—

- (a) cultivating, propagating and harvesting plants or fungi or their products or parts, including seeds, spores, bulbs

Definitions

- or the like, but does not include forestry; or
- (b) maintaining animals in any physical environment for the purposes of—
- (i) breeding them; or
 - (ii) selling them; or
 - (iii) acquiring and selling their bodily produce such as milk, wool, eggs or the like; or
- (c) a combination of (a), and (b),
but does not include forestry or maintaining animals for sport or recreational purposes.

Farm building means a Class 7 or 8 building located on land primarily used for *farming*—

- (a) that is—
- (i) used in connection with *farming*; or
 - (ii) used primarily to store one or more *farm vehicles*; or
 - (iii) a combination of (i) and (ii); and
- (A) in which the total number of persons accommodated at any time does not exceed one person per 200 m² of *floor area* or part thereof, up to a maximum of 8 persons; and
- (B) with a total *floor area* of not more than 3500 m².

State and Territory variation

For Volume One see (*SA, Farm building*)

Farm shed means a single *storey* Class 7 or 8 building located on land primarily used for *farming*—

- (a) that is—
- (i) used in connection with *farming*; or
 - (ii) used primarily to store one or more *farm vehicles*; or
 - (iii) a combination of (i) and (ii); and
- (A) occupied neither frequently nor for extended periods by people; and
- (B) in which the total number of persons accommodated at any time does not exceed 2; and
- (C) with a total *floor area* of more than 500 m² but not more than 2000 m².

Farm vehicle means a vehicle used in connection with *farming*.

Finished ground level, for the purposes of [Part 3.2](#) in Volume Two, means the ground level adjacent to footing systems at the completion of construction and landscaping.

Fire brigade means a statutory authority constituted under an Act of Parliament having as one of its functions, the protection of life and property from fire and other emergencies.

Fire brigade station for the purposes of [E1.3\(a\)\(ii\)](#) and [H3.9](#) in Volume One, means a state or territory government operated premises which is a station for a *fire brigade*.

Fire compartment means—

- (a) the total space of a building; or
- (b) when referred to in—
- (i) the *Performance Requirements* — any part of a building separated from the remainder by barriers to fire such as walls and/or floors having an appropriate resistance to the spread of fire with any openings adequately protected; or
 - (ii) the *Deemed-to-Satisfy Provisions* — any part of a building separated from the remainder by walls and/or floors each having an FRL not less than that *required* for a *fire wall* for that type of construction and where all openings in the separating construction are protected in accordance with the *Deemed-to-Satisfy Provisions* of the relevant Part.

Fire growth means the stage of fire development during which the *heat release rate* and the temperature of the fire are generally increasing.

Fire hazard means the danger in terms of potential harm and degree of exposure arising from the start and spread of fire and the smoke and gases that are thereby generated.

Fire hazard properties means the following properties of a material or assembly that indicate how they behave under specific fire test conditions:

Definitions

- (a) *Average specific extinction area*, *critical radiant flux* and *Flammability Index*, determined as defined in [Schedule 3](#).
- (b) *Smoke-Developed Index*, *smoke development rate* and *Spread-of-Flame Index*, determined in accordance with [Schedule 6](#).
- (c) *Group number* and *smoke growth rate index* (SMOGR_{RC}), determined in accordance with [Specification C1.10](#) of Volume One.

Fire intensity means the rate of release of calorific energy in watts, determined either theoretically or empirically, as applicable.

Fire-isolated passageway means a corridor, hallway or the like, of *fire-resisting construction*, which provides egress to or from a *fire-isolated stairway* or *fire-isolated ramp* or to a road or *open space*.

Fire-isolated ramp means a ramp within a *fire-resisting* enclosure which provides egress from a *storey*.

Fire-isolated stairway means a stairway within a *fire-resisting shaft* and includes the floor and roof or top enclosing structure.

Fire load means the sum of the net calorific values of the *combustible* contents which can reasonably be expected to burn within a *fire compartment*, including furnishings, built-in and removable materials, and building elements. The calorific values must be determined at the ambient moisture content or humidity. (The unit of measurement is MJ.)

Fire-protected timber means *fire-resisting* timber building elements that comply with Volume One [Specification C1.13a](#).

Fire-protective covering means—

- (a) 13 mm fire-protective grade plasterboard; or
- (b) 12 mm cellulose cement flat sheeting complying with AS/NZS 2908.2 or ISO 8336; or
- (c) 12 mm fibrous plaster reinforced with 13 mm x 13 mm x 0.7 mm galvanised steel wire mesh located not more than 6 mm from the exposed face; or
- (d) other material not less fire-protective than 13 mm fire-protective grade plasterboard, fixed in accordance with the normal trade practice for a *fire-protective covering*.

Fire-resistance level (FRL) means the grading periods in minutes determined in accordance with [Schedule 5](#), for the following criteria—

- (a) *structural adequacy*; and
- (b) *integrity*; and
- (c) *insulation*,

and expressed in that order.

Note:

A dash means that there is no requirement for that criterion. For example, 90/-/- means there is no requirement for an FRL for *integrity* and *insulation*, and -/-/- means there is no requirement for an FRL.

Fire-resisting, for the purposes of Volume One, applied to a building element, means having an FRL appropriate for that element.

Fire-resisting, for the purposes of Volume Two, applied to a *structural member* or other part of a building, means having the FRL *required* for that *structural member* or other part.

Fire-resisting construction, for the purposes of Volume One, means one of the Types of construction referred to in [Part C1](#) of Volume One.

Fire safety engineering means application of engineering principles, rules and *expert judgement* based on a scientific appreciation of the fire phenomenon, often using specific *design scenarios*, of the effects of fire and of the reaction and behaviour of people in order to—

- (a) save life, protect property and preserve the environment and heritage from destructive fire; and
- (b) quantify the hazards and risk of fire and its effects; and
- (c) mitigate fire damage by proper design, construction, arrangement and use of buildings, materials, structures, industrial processes and transportation systems; and
- (d) evaluate analytically the optimum protective and preventive measures, including design, installation and maintenance of active and passive fire and life safety systems, necessary to limit, within prescribed levels, the consequences of fire.

Fire safety system means one or any combination of the methods used in a building to

Definitions

- (a) warn people of an emergency; or
 - (b) provide for safe evacuation; or
 - (c) restrict the spread of fire; or
 - (d) extinguish a fire,
- and includes both active and passive systems.

Fire-source feature means—

- (a) the far boundary of a road, river, lake or the like adjoining the allotment; or
- (b) a side or rear boundary of the allotment; or
- (c) an *external wall* of another building on the allotment which is not a Class 10 building.

Fire wall means a wall with an appropriate resistance to the spread of fire that divides a *storey* or building into *fire compartments*.

Fixed wired, for the purposes of *Specification E2.2d* in Volume One, means a system of electrical wiring (either AC or DC), in which cables are fixed or supported in position.

Flammability Index means the index number as determined by AS 1530.2.

Flashing means a strip or sleeve of impervious material dressed, fitted or built-in to provide a barrier to moisture movement, or to divert the travel of moisture, or to cover a joint where water would otherwise penetrate to the interior of a building.

Flashover, in relation to *fire hazard properties*, means a *heat release rate* of 1 MW.

Flight, means that part of a stair that has a continuous series of *risers*, including *risers* of *winders*, not interrupted by a *landing* or floor (for Volume Two, see *Figure 4*).

Explanatory information for Volume Two:

A *flight* is the part of a stair that has a continuous slope created by the nosing line of treads. The length of a *flight* is limited to restrict the distance a person could fall down a stair. Quarter *landings*, as shown in *Figure 4*, are considered sufficient to halt a person's fall and therefore are considered for the purposes of Volume Two not to be part of the *flight*.

Figure 4 Identification of stair flights — Plan view

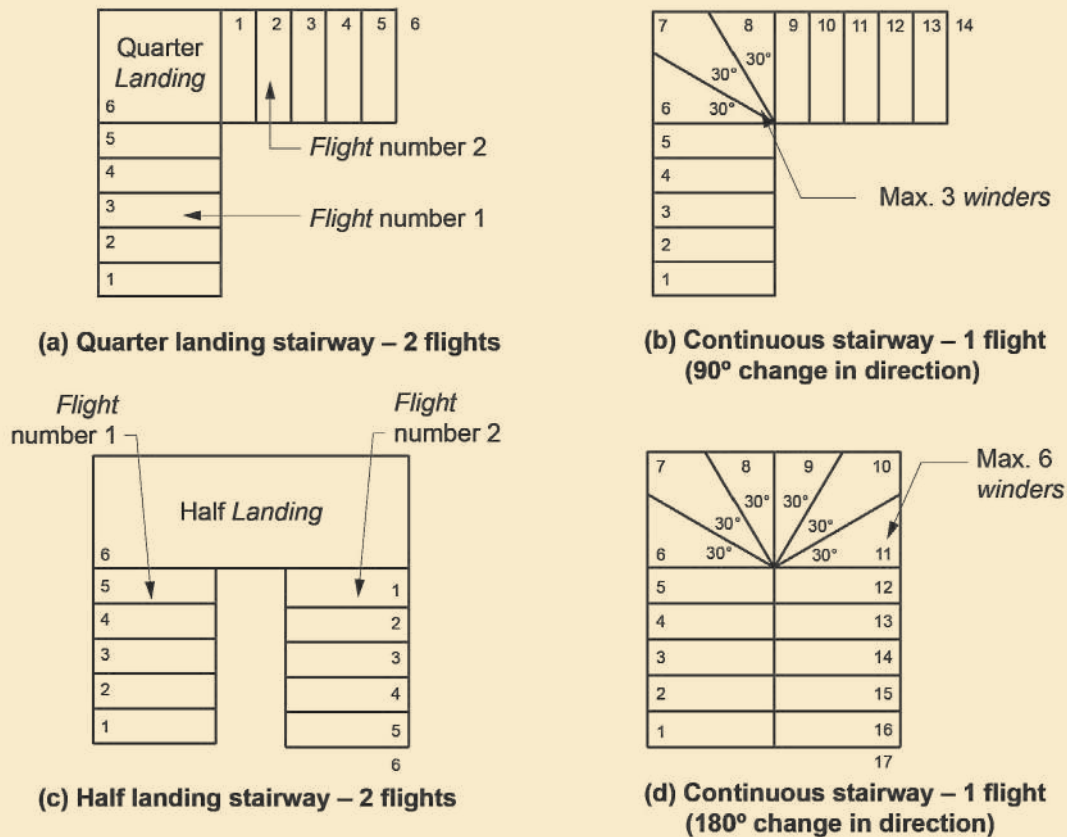

Flood hazard area means the *site* (whether or not mapped) encompassing land lower than the *flood hazard level* which has been determined by the *appropriate authority*.

State and Territory variations

For Volume One see (*Vic, Flood hazard area*)

For Volume Two see (*Vic, Flood hazard area*)

Flood hazard level (FHL) means the flood level used to determine the height of floors in a building and represents the *defined flood level* plus the *freeboard* (see Figure 3).

Floor area, for the purposes of Volume One, means—

- (a) in relation to a building — the total area of all *storeys*; and
- (b) in relation to a *storey* — the area of all floors of that *storey* measured over the enclosing walls, and includes—
 - (i) the area of a *mezzanine* within the *storey*, measured within the finished surfaces of any *external walls*; and
 - (ii) the area occupied by any *internal wall* or partitions, any cupboard, or other built-in furniture, fixture or fitting; and
 - (iii) if there is no enclosing wall, an area which has a use that—
 - (A) contributes to the *fire load*; or
 - (B) impacts on the safety, health or amenity of the occupants in relation to the provisions of the BCA; and
- (c) in relation to a room — the area of the room measured within the finished surfaces of the walls, and includes the area occupied by any cupboard or other built-in furniture, fixture or fitting; and
- (d) in relation to a *fire compartment* — the total area of all floors within the *fire compartment* measured within the finished surfaces of the bounding construction, and if there is no bounding construction, includes an area which has a use which contributes to the *fire load*; and
- (e) in relation to an *atrium* — the total area of all floors within the *atrium* measured within the finished surfaces of the bounding construction and if no bounding construction, within the *external walls*.

Definitions

Floor area, for the purposes of Volume Two, means in relation to a room, the area of the room measured within the finished surfaces of the walls, and includes the area occupied by any cupboard or other built-in furniture, fixture or fitting (see [Figure 5](#)).

Figure 5 Identification of floor area of a room

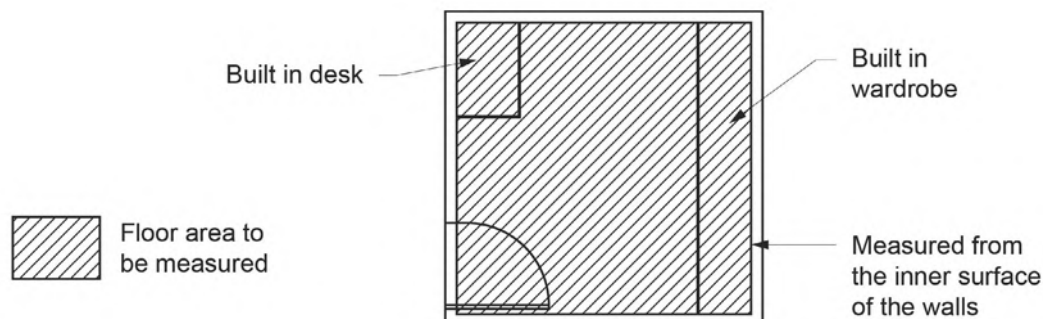

Foundation means the ground which supports the building (see [Figure 6](#)).

Figure 6 Identification of foundation

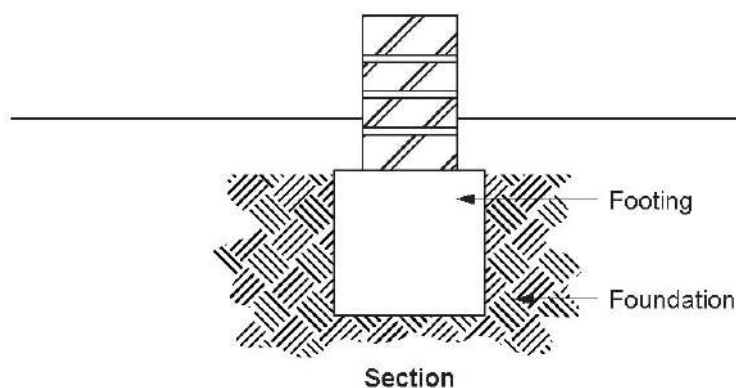

Fractional effective dose (FED) means the fraction of the dose (of thermal effects) that would render a person of average susceptibility incapable of escape.

Explanatory information:

The definition for *FED* has been modified from the ISO definition to be made specific for [Schedule 7](#). The use of CO or CO₂ as part of *FED* is not part of that [Verification Method](#). This is because the ability to measure CO in a repeatable test varies by two orders of magnitude for common cellulosic fuel.

Freeboard means the height above the [defined flood level](#) as determined by the [appropriate authority](#), used to compensate for effects such as wave action and localised hydraulic behaviour.

State and Territory variations

For Volume One see ([Vic](#), [Freeboard](#))

For Volume Two see ([Vic](#), [Freeboard](#))

Fully developed fire means the state of total involvement of the majority of available combustible materials in a fire.

Glazing, for the purposes of [Section J](#) in Volume One, means a transparent or translucent element and its supporting frame located in the [envelope](#), and includes a [window](#) other than a [roof light](#).

Glazing, for the purposes of [Part 2.6](#) and [Part 3.12](#) in Volume Two, means a transparent or translucent element and its supporting frame located in the external [fabric](#) of the building, and includes a [window](#) other than a [roof light](#).

Green Star means the building sustainability rating scheme managed by the Green Building Council of Australia.

Going means the horizontal dimension from the front to the back of a tread less any overhang from the next tread or [landing](#) above (see [Figure 3.9.1.4](#)).

Group number means the number of one of 4 groups of materials used in the regulation of [fire hazard properties](#) and

Definitions

applied to materials used as a finish, surface, lining, or attachment to a wall or ceiling.

Habitable room means a room used for normal domestic activities, and—

- (a) includes a bedroom, living room, lounge room, music room, television room, kitchen, dining room, sewing room, study, playroom, family room, home theatre and sunroom; but
- (b) excludes a bathroom, laundry, water closet, pantry, walk-in wardrobe, corridor, hallway, lobby, photographic darkroom, clothes-drying room, and other spaces of a specialised nature occupied neither frequently nor for extended periods.

Hazard Rating means a rating of either *Low Hazard*, *Medium Hazard* or *High Hazard* determined in accordance with [Specification B5.1](#) in Volume Three, for any *Deemed-to-Satisfy Solution*.

Health-care building means a building whose occupants or patients undergoing medical treatment generally need physical assistance to evacuate the building during an emergency and includes—

- (a) a public or private hospital; or
- (b) a nursing home or similar facility for sick or disabled persons needing full-time care; or
- (c) a clinic, day surgery or procedure unit where the effects of the predominant treatment administered involve patients becoming non-ambulatory and requiring supervised medical care on the premises for some time after the treatment.

Heated water means water that has been intentionally heated. It is normally referred to as hot water or warm water.

Heating load means the calculated amount of energy delivered to the heated spaces of the building annually by artificial means to maintain the desired temperatures in those spaces.

Heat release means the thermal energy produced by combustion (kJ).

Heat release rate (HRR) means the rate of thermal energy production generated by combustion (kW (preferred) or MW).

High Hazard means any condition, device or practice which, in connection with a water supply, has the potential to cause death.

High wind area means a region that is subject to *design wind speed* more than N3 or C1 (see [Table 3](#)).

Horizontal exit means a *required* doorway between 2 parts of a building separated from each other by a *fire wall*.

Hours of operation means the number of hours when the occupancy of the building is greater than 20% of the peak occupancy.

House energy rating software, for the purposes of Volume One, means software accredited under the Nationwide House Energy Rating Scheme.

House energy rating software, for the purposes of Volume Two—

- (a) applied to [V2.6.2.2](#)—means software accredited or previously accredited under the Nationwide House Energy Rating Scheme and the additional functionality provided in non-regulatory mode; and
- (b) applied to [3.12.0.1](#)—means software accredited under the Nationwide House Energy Rating Scheme.

Explanatory information:

The Nationwide House Energy Rating Scheme (NatHERS) refers to the Australian governments' scheme that facilitates consistent energy ratings from software tools which are used to assess the potential thermal efficiency of dwelling envelopes.

Housing Provisions means the requirements for Class 1 and 10 buildings contained in Volume Two of the National Construction Code as published by the Australian Building Codes Board.

Illuminance means the luminous flux falling onto a unit area of surface.

Illumination power density (W/m²) means the total of the power that will be consumed by the lights in a space, including any lamps, ballasts, current regulators and control devices other than those that are plugged into socket outlets for intermittent use such as floor standing lamps, desk lamps or work station lamps, divided by the area of the space.

Explanatory information:

- *Illumination power density* relates to the power consumed by the lighting system and includes the light source or luminaire and any control device. The power for the lighting system is the illumination power load. This approach is more complicated than the *lamp power density* approach but provides more flexibility for a dwelling with sophisticated control systems.
- The area of the space refers to the area the lights serve. This could be considered a single room, open plan space, verandah, balcony or the like, or the total area of all these spaces.

Inclined lift means a power-operated device for raising or lowering people within a carriage that has one or more rigid

Definitions

guides on an inclined plane.

Individual protection means the installation of a [backflow prevention device](#) at the point where a water service connects to a single fixture or appliance.

Insulation, in relation to an FRL, means the ability to maintain a temperature on the surface not exposed to the furnace below the limits specified in AS 1530.4.

Integrity, in relation to an FRL, means the ability to resist the passage of flames and hot gases specified in AS 1530.4.

Internal wall, for the purposes of Volume One, excludes a [common wall](#) or a party wall.

Internal wall, for the purposes of Volume Two, excludes a [separating wall](#), [common wall](#) or party wall.

Interstitial condensation means the [condensation](#) of moisture on surfaces between material layers inside the building component.

JAS-ANZ means the Joint Accreditation System of Australia and New Zealand.

Lamp power density (W/m²) means the total of the maximum power rating of the lamps in a space, other than those that are plugged into socket outlets for intermittent use such as floor standing lamps, desk lamps or work station lamps, divided by the area of the space.

Explanatory information:

- [Lamp power density](#) is a simple means of setting energy consumption at an efficient level for Class 1 and associated Class 10a buildings.
- Lamp refers to the globe or globes that are to be installed in a permanently wired light fitting. The maximum power of a lamp is usually marked on the fitting as the maximum allowable wattage.
- The area of the space refers to the area the lights serve. This could be considered a single room, open plan space, verandah, balcony or the like, or the total area of all these spaces.

Landing means an area at the top or bottom of a [flight](#) or between two [flights](#).

Latent heat gain means the heat gained by the vapourising of liquid without change of temperature.

Lightweight construction means construction which incorporates or comprises—

- (a) sheet or board material, plaster, render, sprayed application, or other material similarly susceptible to damage by impact, pressure or abrasion; or
- (b) concrete and concrete products containing pumice, perlite, vermiculite, or other soft material similarly susceptible to damage by impact, pressure or abrasion; or
- (c) masonry having a width of less than 70 mm.

Loadbearing means intended to resist vertical forces additional to those due to its own weight.

Loadbearing wall, for the purposes of [Part 3.2](#) in Volume Two, means any wall imposing on the footing a load greater than 10 kN/m.

Loss means either: physical damage, financial loss or loss of [amenity](#).

Low Hazard means any condition, device or practice which, in connection with a water supply, would constitute a nuisance by colour, odour or taste but does not have the potential to injure or endanger health.

Low rainfall intensity area means an area with a 5 minute rainfall intensity for an [average recurrence interval](#) of 20 years of not more than 125 mm/hour.

Explanatory information:

Rainfall intensity figures can be obtained from [Tables 3.5.3.1a to 3.5.3.1h](#) in Volume Two.

Low-rise, low-speed constant pressure lift means a power-operated low-rise, low-speed device for raising or lowering people with limited mobility on a carriage that is controlled by the application of constant pressure to a control.

Low-rise platform lift means a power-operated device for raising or lowering people with limited mobility on a platform, that is controlled automatically or by the application of constant pressure to a control.

Low voltage means a [voltage](#) exceeding [extra-low voltage](#), but not exceeding 1000 V AC or 1500 V DC.

Luminance contrast means the light reflected from one surface or component, compared to the light reflected from another surface or component.

Massive timber means an element not less than 75 mm thick as measured in each direction formed from solid and laminated timber.

Medium Hazard means any condition, device or practice which, in connection with a water supply, has the potential to injure or endanger health.

Minimum Energy Performance Standards (MEPS) means the Minimum Energy Performance Standards for equipment and appliances established through the Greenhouse and Energy Minimum Standards Act 2012.

Definitions

Mixed construction means a building consisting of more than one form of construction, particularly in double-storey buildings.

Mezzanine means an intermediate floor within a room.

Mould means a fungal growth that can be produced from conditions such as dampness, darkness, or poor ventilation.

NABERS Energy for Offices means the National Australia Built Environment Rating Systems for office energy efficiency, which is managed by the New South Wales Government.

Network Utility Operator means a person who—

- (a) undertakes the piped distribution of *drinking water* or *non-drinking water* for supply; or
- (b) is the operator of a sewerage system or a stormwater *drainage* system.

Explanatory information:

A *Network Utility Operator* in most States and Territories is the water and sewerage authority licensed to supply water and receive sewage and/or stormwater. The authority operates or proposes to operate a network that undertakes the distribution of water for supply and undertakes to receive sewage and/or stormwater drainage. This authority may be a licensed utility, local government body or council.

State and Territory variation

For Volume Three see (*Tas, Network Utility Operator*)

Non-combustible means—

- (a) applied to a material — not deemed *combustible* as determined by AS 1530.1 — Combustibility Tests for Materials; and
- (b) applied to construction or part of a building — constructed wholly of materials that are not deemed *combustible*.

Non-drinking water means water which is not *drinking water*.

Occupant traits, for the purposes of Volume One, means the features, needs and profile of the occupants in a *habitable room* or space.

Occupant traits, for the purposes of Volume Two, means the features, needs and profile of the occupants in a room or space.

Explanatory information:

This term is used to describe the characteristics of the occupants and their associated requirements in relation to a room or space.

For example, in relation to a bedroom, the following occupant characteristics and associated requirements should be considered:

- Characteristics: height, mobility and how often the space will be used.
- Requirements: a sleeping space and a space to undertake leisure activities.

Occupiable outdoor area means a space on a roof, balcony or similar part of a building—

- (a) that is open to the sky; and
- (b) to which access is provided, other than access only for maintenance; and
- (c) that is not *open space* or directly connected with *open space*.

On-site wastewater management system means a system installed on premises that receives and/or treats wastewater generated on the premises and applies the resulting effluent to an *approved disposal system* or re-use system.

State and Territory variation

For Volume Three see (*Tas, On-site wastewater management system*)

Open-deck carpark means a carpark in which all parts of the parking *storeys* are cross-ventilated by permanent unobstructed openings in not fewer than 2 opposite or approximately opposite sides, and—

- (a) each side that provides ventilation is not less than $\frac{1}{6}$ of the area of any other side; and
- (b) the openings are not less than $\frac{1}{2}$ of the wall area of the side concerned.

Open space means a space on the allotment, or a roof or similar part of a building adequately protected from fire, open to the sky and connected directly with a public road.

Open spectator stand means a tiered stand substantially open at the front.

Definitions

Other property means all or any of the following—

- (a) any building on the same or an adjoining allotment; and
- (b) any adjoining allotment; and
- (c) a road.

Outdoor air means air outside the building.

Outdoor air economy cycle is a mode of operation of an *air-conditioning* system that, when the *outdoor air* thermodynamic properties are favourable, increases the quantity of *outdoor air* used to condition the space.

Outfall means that part of the disposal system receiving *surface water* from the drainage system and may include a natural water course, kerb and channel, or soakage system.

Overflow devices means a device that provides relief to a water service, sanitary *plumbing* and *drainage* system, *rainwater harvesting system* or stormwater system to avoid the likelihood of *uncontrolled discharge*.

Panel wall means a non-*loadbearing external wall*, in frame or similar construction, that is wholly supported at each *storey*.

Patient care area means a part of a *health-care building* normally used for the treatment, care, accommodation, recreation, dining and holding of patients including a *ward area* and *treatment area*.

Performance-based design brief (PBDB), for the purposes of *Schedule 7*, means the process and the associated report that defines the scope of work for the performance-based *fire safety engineering* analysis and the technical basis for analysis as agreed by stakeholders.

Performance Requirement means a requirement which states the level of performance which a *Performance Solution* or *Deemed-to-Satisfy Solution* must meet.

Performance Solution means a method of complying with the *Performance Requirements* other than by a *Deemed-to-Satisfy Solution*.

Perimeter of building, for the purposes of *Part 3.6* in Volume Two, means the external envelope of a building.

Personal care services means any of the following:

- (a) The provision of nursing care.
- (b) Assistance or supervision in—
 - (i) bathing, showering or personal hygiene; or
 - (ii) toileting or continence management; or
 - (iii) dressing or undressing; or
 - (iv) consuming food.
- (c) The provision of direct physical assistance to a person with mobility problems.
- (d) The management of medication.
- (e) The provision of substantial rehabilitative or development assistance.

Piping, for the purposes of *Section J* in Volume One or *Part 3.12* in Volume Two, means an assembly of pipes, with or without valves or other fittings, connected together for the conveyance of liquids and gases.

Pliable building membrane means a water barrier as classified by AS/NZS 4200.1.

Plumbing means any water *plumbing*, roof *plumbing*, sanitary *plumbing* system or heating, ventilation and air-conditioning *plumbing*.

Plumbing or Drainage Solution means a solution which complies with the *Performance Requirements* and is a—

- (a) *Performance Solution*; or
- (b) *Deemed-to-Satisfy Solution*; or
- (c) combination of (a) and (b).

Point of connection —

- (a) for a *heated water* service means the point where the water heater connects to the cold water service downstream of the isolation valve; and
- (b) for sewage disposal means the point where the on-site *drainage* system connects to the *Network Utility Operator's* sewerage system or to an *on-site wastewater management system*; and
- (c) for stormwater disposal means the point where the on-site *drainage* system connects to the *Network Utility Operator's* stormwater system or to an *approved disposal system*; and
- (d) for a water service means the point where the service pipe within the premises connects to the *Network Utility Operator's* property service or to an alternative water supply system.

Definitions

Predicted Mean Vote (PMV) means the Predicted Mean Vote of the thermal perception of building occupants determined in accordance with ANSI/ASHRAE Standard 55.

Pressure vessel means a vessel subject to internal or external pressure. It includes interconnected parts and components, valves, gauges and other fittings up to the first point of connection to connecting piping, and—

- (a) includes fire heaters and gas cylinders; but
- (b) excludes—
 - (i) any vessel that falls within the definition of a *boiler*; and
 - (ii) storage tanks and equipment tanks intended for storing liquids where the pressure at the top of the tank is not exceeding 1.4 kPa above or 0.06 kPa below atmospheric pressure; and
 - (iii) domestic-type hot water supply heaters and tanks; and
 - (iv) pressure vessels installed for the purposes of fire suppression or which serve a fire suppression system.

Primary building element, for the purposes of Volume One, means a member of a building designed specifically to take part of the loads specified in [B1.2](#) and includes roof, ceiling, floor, stairway or ramp and wall framing members including bracing members designed for the specific purpose of acting as a brace to those members.

Primary building element, for the purposes of [Part 3.1.4](#) in Volume Two, means a member of a building designed specifically to take part of the building loads and includes roof, ceiling, floor, stairway or ramp and wall framing members including bracing members designed for the specific purpose of acting as a brace to those members.

Explanatory information:

The loads to which a building may be subjected are dead, live, wind, snow and earthquake loads. Further information on building loads can be found in the AS 1170 series of Standards.

State and Territory variation

For Volume Two see ([Qld, Primary building element](#))

Private bushfire shelter means a structure associated with, but not attached to, or part of a Class 1a dwelling that may, as a last resort, provide shelter for occupants from immediate life threatening effects of a bushfire.

Private garage, for the purposes of Volume One, means—

- (a) any garage associated with a Class 1 building; or
- (b) any single *storey* of a building of another Class containing not more than 3 vehicle spaces, if there is only one such *storey* in the building; or
- (c) any separate single *storey* garage associated with another building where such garage contains not more than 3 vehicle spaces.

Private garage, for the purposes of Volume Two, means—

- (a) any garage associated with a Class 1 building; or
- (b) any separate single *storey* garage associated with another building where such garage contains not more than 3 vehicle spaces.

Product means *plumbing* and *drainage* items within the scope of the PCA including but not limited to:

- (a) Materials, fixtures and components used in a *plumbing* or *drainage* installation.
- (b) Appliances and equipment connected to a *plumbing* or *drainage* system.

Product Technical Statement means a form of documentary evidence stating that the properties and performance of a building material, product or form of construction fulfil specific requirements of the NCC, and describes—

- (a) the application and intended use of the building material, product or form of construction: and
- (b) how the use of the building material, product or form of construction complies with the requirements of the NCC Volume One and Volume Two; and
- (c) any limitations and conditions of the use of the building material, product or form of construction relevant to (b).

Professional engineer means a person who is—

- (a) if legislation is applicable — a registered *professional engineer* in the relevant discipline who has appropriate experience and competence in the relevant field; or
- (b) if legislation is not applicable—

Definitions

- (i) registered in the relevant discipline on the National Engineering Register (NER) of the Institution of Engineers Australia (which trades as 'Engineers Australia'); or
- (ii) eligible to become registered on the Institution of Engineers Australia's NER and has appropriate experience and competence in the relevant field.

State and Territory variation

For Volume Three see (*Tas, Professional engineer*)

Public corridor means an enclosed corridor, hallway or the like which—

- (a) serves as a means of egress from 2 or more *sole-occupancy units* to a *required exit* from the *storey* concerned; or
- (b) is *required* to be provided as a means of egress from any part of a *storey* to a *required exit*.

R-Value (m².K/W) means the thermal resistance of a component calculated by dividing its thickness by its thermal conductivity.

Rapid roller door means a door that opens and closes at a speed of not less than 0.5 m/s.

Rainwater harvesting system means a *plumbing* installation that comprises—

- (a) any *plumbing* that connects a rainwater tank to any *drinking water* or *non-drinking water* outlets; and
- (b) any top-up line that conveys *drinking water* from a *Network Utility Operator's* water supply to a rainwater tank.

Recognised expert means a person with qualifications and experience in the area of *plumbing* or *drainage* in question recognised by the authority having jurisdiction.

Explanatory information:

A *recognised expert* is a person recognised by the authority having jurisdiction as qualified to provide evidence under *A5.3(5)*. Generally, this means a hydraulic consultant or engineer, however the specific requirements are determined by the authority having jurisdiction.

Under *A5.3(5)*, a report from a *recognised expert* may be used as evidence of suitability that a *product* listed on the *WaterMark Schedule of Excluded Products*, or a *plumbing* or *drainage* system, complies with a *Performance Requirement* or *Deemed-to-Satisfy Provision*.

State and Territory variation

For Volume Three see (*Tas, Recognised expert*)

Reference building, for the purposes of Volume One, means a hypothetical building that is used to calculate the maximum allowable *annual greenhouse gas emissions* and determine the *Thermal comfort level* for the proposed building.

Reference building, for the purposes of Volume Two, means a hypothetical building that is used to determine the maximum allowable *heating load* and *cooling load* for the proposed building.

Reflective insulation means a building membrane with a reflective surface such as a reflective foil laminate, reflective barrier, foil batt or the like capable of reducing radiant heat flow.

Explanatory information for Volume Two:

- (a) Typical *R-Values* achieved by adding *reflective insulation* are given in the explanatory information accompanying *Figures 3.12.1.1, 3.12.1.3 and 3.12.1.4*. Information on specific products may be obtained from *reflective insulation* manufacturers.
- (b) The surface of *reflective insulation* may be described in terms of its emittance (or infra-red emittance) or in terms of its reflectance (or solar reflectance). Generally, for the surface of a particular *reflective insulation* –
- (c) emittance + reflectance = 1.
- (d) Some types of *reflective insulation* may also serve the purposes of waterproofing or vapour proofing.

Regulated energy means the energy consumed by a building's *services* minus the amount of *renewable energy* generated and used on *site*.

Reinforced masonry means masonry reinforced with steel reinforcement that is placed in a bed joint or grouted into a core to strengthen the masonry.

Renewable energy means energy that is derived from sources that are regenerated, replenished, or for all practical purposes cannot be depleted and the energy sources include, but are not limited to, solar, wind, hydroelectric, wave action and geothermal.

Required means *required* to satisfy a *Performance Requirement* or a *Deemed-to-Satisfy Provision* of the NCC as

Definitions

appropriate.

Required safe egress time (RSET) means the time required for safe evacuation of occupants to a place of safety prior to the onset of untenable conditions.

Residential aged care building means a Class 3 or 9a building whose residents, due to their incapacity associated with the ageing process, are provided with physical assistance in conducting their daily activities and to evacuate the building during an emergency.

Residential care building means a Class 3, 9a or 9c building which is a place of residence where 10% or more of persons who reside there need physical assistance in conducting their daily activities and to evacuate the building during an emergency (including any *aged care building* or *residential aged care building*) but does not include a hospital.

Resident use area means part of a Class 9c building normally used by residents, and—

- (a) includes *sole-occupancy units*, lounges, dining areas, activity rooms and the like; but
- (b) excludes offices, storage areas, commercial kitchens, commercial laundries and other spaces not for the use of residents.

Resistance to the incipient spread of fire, in relation to a ceiling membrane, means the ability of the membrane to insulate the space between the ceiling and roof, or ceiling and floor above, so as to limit the temperature rise of materials in this space to a level which will not permit the rapid and general spread of fire throughout the space.

Explanatory information:

Resistance to the incipient spread of fire refers to the ability of a ceiling to prevent the spread of fire and thermally insulate the space between the ceiling and the roof or floor above. “*Resistance to the incipient spread of fire*” is superior to “fire-resistance” because it requires a higher standard of heat insulation.

The definition is used in Volume Two for separating floors/ceilings for a Class 1a dwelling located above a non-appurtenant *private garage*.

Rise in storeys means the greatest number of *storeys* calculated in accordance with [C1.2 of Volume One](#).

Riser means the height between consecutive treads and between each *landing* and continuous tread.

Roof light, for the purposes of [Section J](#) and [Part F4](#) in Volume One, and [Parts 2.6, 3.8.4 and 3.12](#) in Volume Two, means a skylight, *window* or the like installed in a roof—

- (a) to permit natural light to enter the room below; and
- (b) at an angle between 0 and 70 degrees measured from the horizontal plane.

Rolled fill means material placed in layers and compacted by repeated rolling by an excavator.

Safe place means—

- (a) a place of safety within a building—
 - (i) which is not under threat from a fire; and
 - (ii) from which people must be able to safely disperse after escaping the effects of an emergency to a road or *open space*; or
- (b) a road or *open space*.

Sanitary compartment means a room or space containing a closet pan or urinal (see [Figure 7](#)).

Figure 7 Identification of a sanitary compartment

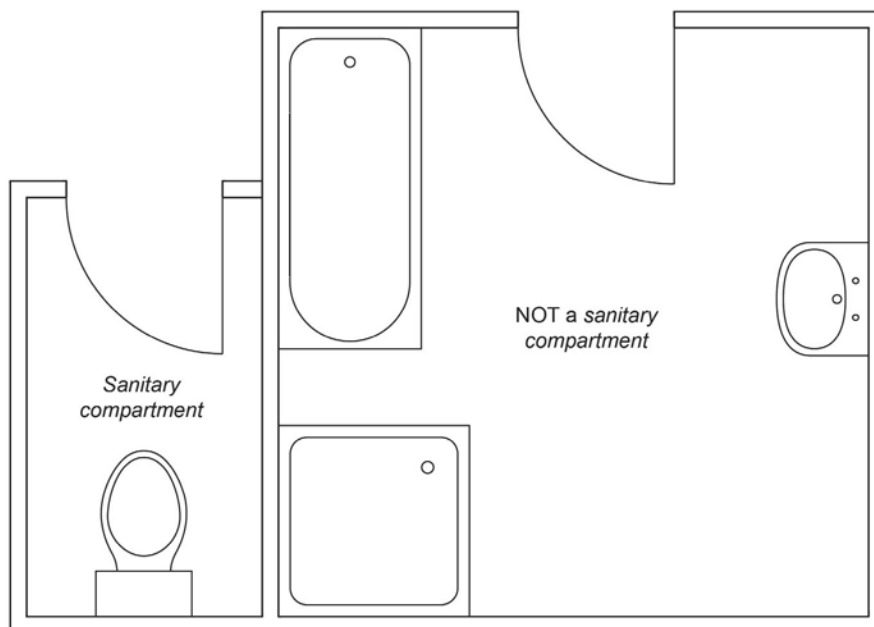
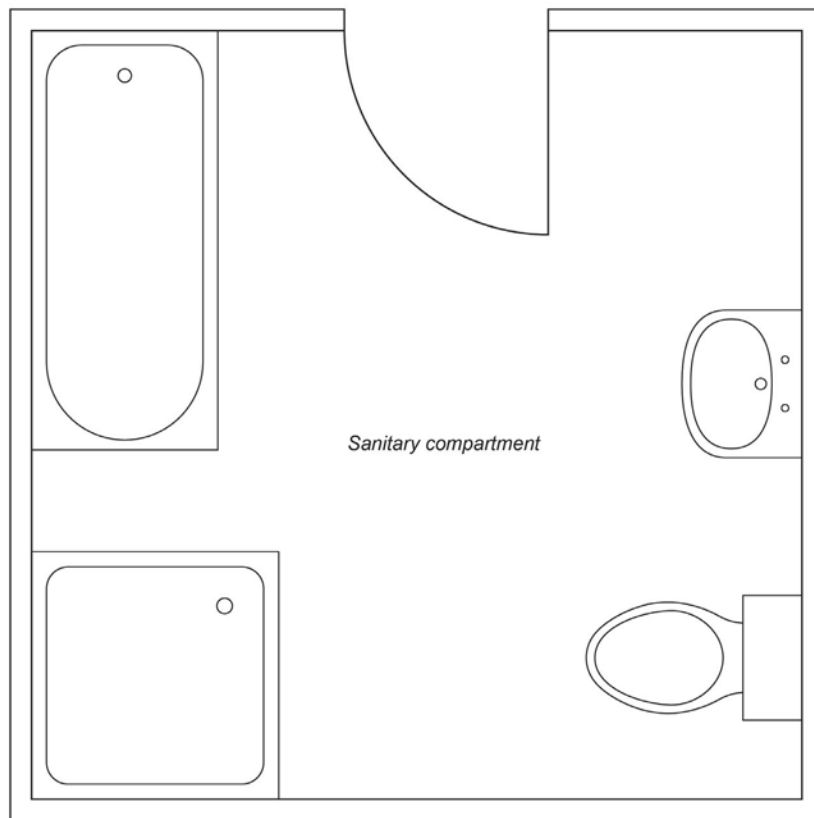

Sarking-type material means a material such as a *reflective insulation* or other flexible membrane of a type normally used for a purpose such as waterproofing, vapour management or thermal reflectance.

School includes a primary or secondary *school*, college, university or similar educational establishment.

Self-closing, for the purposes of Volume One, applied to a door, means equipped with a device which returns the door to the fully closed position immediately after each opening.

Self-closing, for the purposes of Volume Two, applied to a door or *window*, means equipped with a device which returns the door or *window* to the fully closed and latched position immediately after each manual opening.

Definitions

Sensible heat gain means the heat gained which causes a change in temperature

Separating element means a barrier that exhibits fire *integrity*, *structural adequacy*, *insulation*, or a combination of these for a period of time under specified conditions (often in accordance with AS 1530.4).

Separating wall means a wall that is common to adjoining Class 1 buildings (see [Figure 8](#)).

Figure 8 Separating wall

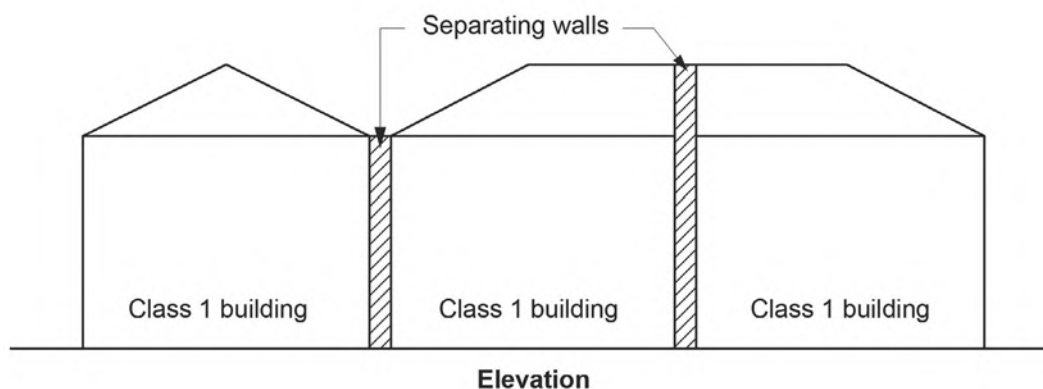

Note:

In Volume Two may also be known as a party wall and typically is *required* to be *fire-resisting* construction (see [Parts 3.7.2](#) and [3.7.3](#)).

Service, for the purposes of [Section J](#) in Volume One, means a mechanical or electrical system that uses energy to provide *air-conditioning*, mechanical ventilation, heated water supply, artificial lighting, vertical transport and the like within a building, but which does not include—

- (a) systems used solely for emergency purposes; and
- (b) cooking facilities; and
- (c) portable appliances.

Service station means a garage which is not a *private garage* and is for the servicing of vehicles, other than only washing, cleaning or polishing.

Shaft means the walls and other parts of a building bounding—

- (a) a well, other than an *atrium well*; or
- (b) a vertical chute, duct or similar passage, but not a chimney or flue.

Shower area means the area affected by water from a shower, including a shower over a bath.

Single leaf masonry means outer walls constructed with a single thickness of masonry unit.

Site means the part of the allotment of land on which a building stands or is to be erected.

Sitework means work on or around a *site*, including earthworks, preparatory to or associated with the construction, *alteration*, demolition or removal of a building.

Small-scale Technology Certificate means a certificate issued under the Commonwealth Government's Small-scale Renewable Energy Scheme.

Small-sized, low-speed automatic lift means a restricted use power-operated device for the infrequent raising or lowering of people with limited mobility on a platform that is controlled automatically but has the capability of being electrically isolated by a key-lockable control.

Smoke-and-heat vent means a vent, located in or near the roof for smoke and hot gases to escape if there is a fire in the building.

Smoke-Developed Index means the index number for smoke as determined by AS/NZS 1530.3.

Smoke development rate means the development rate for smoke as determined by testing flooring materials in accordance with AS ISO 9239.1.

Smoke growth rate index (SMOGR_{RC}) means the index number for smoke used in the regulation of *fire hazard properties* and applied to materials used as a finish, surface, lining or attachment to a wall or ceiling.

Definitions

Solar admittance means the fraction of incident irradiance on a *wall-glazing construction* that adds heat to a building's space.

Sole-occupancy unit means a room or other part of a building for occupation by one or joint owner, lessee, tenant, or other occupier to the exclusion of any other owner, lessee, tenant, or other occupier and includes—

- (a) a dwelling; or
- (b) a room or suite of rooms in a Class 3 building which includes sleeping facilities; or
- (c) a room or suite of associated rooms in a Class 5, 6, 7, 8 or 9 building; or
- (d) a room or suite of associated rooms in a Class 9c building, which includes sleeping facilities and any area for the exclusive use of a resident.

Spandrel panel, for the purposes of [Section J](#) of Volume One, means the opaque part of a façade in curtain wall construction which is commonly adjacent to, and integrated with, *glazing*.

Spiral stairway means a stairway with a circular plan, winding around a central post with steps that radiate from a common centre or several radii (see [Figures 3.9.1.2\(a\)](#) and [\(b\)](#)).

Spread-of-Flame Index means the index number for spread of flame as determined by AS/NZS 1530.3.

Sprinkler alarm switch, for the purposes of [Specification E2.2d](#) of Volume One, means a device capable of sending an electrical signal to activate an alarm when a residential sprinkler head is activated (e.g. a flow switch).

Stage means a floor or platform in a Class 9b building on which performances are presented before an audience.

Stairway platform lift means a power-operated device for raising or lowering people with limited mobility on a platform (with or without a chair) in the direction of a stairway.

Standard Fire Test means the Fire-resistance Tests of Elements of Building Construction as described in AS 1530.4.

Storey means a space within a building which is situated between one floor level and the floor level next above, or if there is no floor above, the ceiling or roof above, but not—

- (a) a space that contains only—
 - (i) a lift *shaft*, stairway or meter room; or
 - (ii) a bathroom, shower room, laundry, water closet, or other *sanitary compartment*; or
 - (iii) accommodation intended for not more than 3 vehicles; or
 - (iv) a combination of the above; or
- (b) a *mezzanine*.

Structural adequacy, in relation to an FRL, means the ability to maintain stability and adequate *loadbearing* capacity as determined by AS 1530.4.

Structural member means a component or part of an assembly which provides vertical or lateral support to a building or structure.

Surface water means all naturally occurring water, other than sub-*surface water*, which results from rainfall on or around the *site* or water flowing onto the *site*.

Swimming pool means any excavation or structure containing water and principally used, or that is designed, manufactured or adapted to be principally used for swimming, wading, paddling, or the like, including a bathing or wading pool, or spa.

Tapered tread means a stair tread with a walking area that grows smaller towards one end.

Thermal comfort level means the level of thermal comfort in a building expressed as a *PMV* sensation scale.

Total R-Value (m².K/W), for the purposes of Volume One, means the sum of the *R-Values* of the individual component layers in a composite element including any building material, insulating material, airspace, thermal bridging and associated surface resistances.

Total R-Value (m².K/W), for the purposes of Volume Two, means the sum of the *R-Values* of the individual component layers in a composite element including any building material, insulating material, airspace and associated surface resistances.

Total System Solar Heat Gain Coefficient (SHGC), for the purposes of Volume One, means the fraction of incident irradiance on a *wall-glazing construction* or a *roof light* that adds heat to a building's space.

Total System Solar Heat Gain Coefficient (SHGC), for the purposes of Volume Two, means the fraction of incident irradiance on *glazing* or a *roof light* that adds heat to a building's space.

Total System U-Value (W/m².K), for the purposes of Volume One, means the thermal transmittance of the composite element allowing for the effect of any airspaces, thermal bridging and associated surface resistances.

Total System U-Value (W/m².K), for the purposes of Volume Two, means the thermal transmittance of the composite element allowing for the effect of any airspaces and associated surface resistances.

Definitions

Treatment area means an area within a *patient care area* such as an operating theatre and rooms used for recovery, minor procedures, resuscitation, intensive care and coronary care from which a patient may not be readily moved.

Uncontrolled discharge means any unintentional release of fluid from a *plumbing* and *drainage* system and includes leakage and seepage.

Unique wall, for the purposes of *FV1.1* in Volume One and *V2.2.1* in Volume Two, means a wall which is neither a *cavity wall* nor a *direct fix cladding wall*.

Unobstructed opening, for the purposes of *Part 3.6* in Volume Two, means a glazed area that a person could mistake for an open doorway or clearway and walk into the glazed panel.

Unreinforced masonry means masonry that is not reinforced.

Vapour pressure means the pressure at which water vapour is in thermodynamic equilibrium with its condensed state.

Ventilation opening means an opening in the *external wall*, floor or roof of a building designed to allow air movement into or out of the building by natural means including a permanent opening, an openable part of a *window*, a door or other device which can be held open.

Verification Method means a test, inspection, calculation or other method that determines whether a *Performance Solution* complies with the relevant *Performance Requirements*.

Vessel, for the purposes of Volume One and *Part 3.8.1* in Volume Two, means an open, pre-formed, pre-finished concave receptacle capable of holding water, usually for the purpose of washing, including a basin, sink, bath, laundry tub and the like.

Visibility means the maximum distance at which an object of defined size, brightness and contrast can be seen and recognised.

Voltage means a difference of potential, measured in Volts (V) and includes *extra-low voltage* and *low voltage*.

Waffle raft means a stiffened raft with closely spaced ribs constructed on the ground and with slab panels supported between ribs.

Wall-glazing construction, for the purposes of *Section J* in Volume One, means the combination of wall and *glazing* components comprising the *envelope* of a building, excluding—

- (a) *display glazing*; and
- (b) opaque non-glazed openings such as doors, vents, penetrations and shutters.

Ward area means that part of a *patient care area* for resident patients and may contain areas for accommodation, sleeping, associated living and nursing facilities.

Water control layer means a *pliable building membrane* or the exterior cladding when no *pliable building membrane* is present.

WaterMark Conformity Assessment Body (WMCAB) means a conformity assessment body registered with and accredited by the *JAS-ANZ* to conduct evaluations leading to *product* certification and contracted with the *administering body* to issue the *WaterMark Licence*.

WaterMark Certification Scheme means the ABCB scheme for certifying and authorising *plumbing* and *drainage products*.

WaterMark Licence means a licence issued by a *WaterMark Conformity Assessment Body*.

WaterMark Schedule of Excluded Products means the list maintained by the *administering body* of *products* excluded from the *WaterMark Certification Scheme*.

WaterMark Schedule of Products means the list maintained by the *administering body* of *products* included in the *WaterMark Certification Scheme*, and the specifications to which the *products* can be certified.

Explanatory Information:

The *WaterMark Schedule of Products* and the *WaterMark Schedule of Excluded Products* can be viewed on the ABCB website at www.abcb.gov.au.

Waterproof means the property of a material that does not allow moisture to penetrate through it.

Water resistant means the property of a system or material that restricts moisture movement and will not degrade under conditions of moisture.

Water sensitive materials means materials that have an inherent capacity to absorb water vapour and include timber, plasterboard, plywood, oriented strand board and the like.

Watertight means will not allow water to pass from the inside to the outside of the component or joint and vice versa.

Wet area means an area within a building supplied with water from a water supply system, which includes bathrooms, showers, laundries and *sanitary compartments* and excludes kitchens, bar areas, kitchenettes or domestic food and beverage preparation areas.

Definitions

Winders means treads within a straight *flight* that are used to change direction of the stair (see [Figure 4](#)).

Window includes a *roof light*, glass panel, glass block or brick, glass louvre, glazed sash, glazed door, or other device which transmits natural light directly from outside a building to the room concerned when in the closed position.

Yield means the mass of a combustion product generated during combustion divided by the mass loss of the test specimen as specified in the *design fire*.

Zone protection means the installation of a *backflow prevention device* at the point where a water service is connected to multiple fixtures or appliances, with no *backflow prevention device* installed as *individual protection* downstream of this point.

Referenced Documents

Schedule 4 Referenced documents

Schedule 4 Referenced Documents

Schedule 4 Referenced documents

Schedule of referenced documents

State and Territory variations for Volume One—Schedule of referenced documents

State and Territory variations for Volume Two—Schedule of referenced documents

State and Territory variations for Volume Three—Schedule of referenced documents

Referenced Documents

Schedule 4 Referenced documents

Schedule of referenced documents

The Standards and other documents listed in [Schedule 4](#) are referred to in the NCC.

Table 1 Schedule of referenced documents

No.	Date	Title	Volume One	Volume Two	Volume Three
AS/NZS ISO 717 Part 1	2004	Acoustics — Rating of sound insulation in buildings and of building elements — Airborne sound insulation See Note 1	FV5.1 , FV5.2 , FV5.3 , FV5.4 , F5.2	V2.4.6 , 3.8.6.3	N/A
AS ISO 717 Part 2	2004	Acoustics — Rating of sound insulation in buildings and of building elements — Impact sound insulation	FV5.1 , FV5.3 , F5.3	N/A	N/A
AS 1056 Part 1	1991	Storage water heaters — General requirements (incorporating amendments 1, 2, 3, 4 and 5)	N/A	N/A	B2.2
AS/NZS 1170 Part 0	2002	Structural design actions — General principles (incorporating amendments 1, 3 and 4)	BV1 , B1.1 , Spec B1.2	V2.1.1 , 3.0.2 , 3.5.1.0	N/A
AS/NZS 1170 Part 1	2002	Structural design actions — Permanent, imposed and other actions (incorporating amendments 1 and 2)	B1.2	3.0.3 , 3.0.4 , 3.9.1.2 , 3.9.1.3 , 3.9.2 , 3.9.2.3 ,	N/A
AS/NZS 1170 Part 2	2011	Structural design actions — Wind actions (incorporating amendments 1, 2, 3, 4 and 5)	B1.2 , B1.4 , Spec B1.2 , FV1.1 , Schedule 3	V2.2.1 , 3.0.3 , 3.5.1.0 , Schedule 3	Schedule 3
AS/NZS 1170 Part 3	2003	Structural design actions — Snow and ice actions (incorporating amendments 1 and 2)	B1.2 , Schedule 3	3.0.3 , Schedule 3	Schedule 3
AS 1170 Part 4	2007	Structural design actions — Earthquake actions in Australia (incorporating amendments 1 and 2)	B1.2	3.0.3 , 3.3.5.1 , 3.3.6.1 , 3.4.4.1 , 3.10.2.0	N/A
AS 1191	2002	Acoustics — Method for laboratory measurement of airborne sound transmission insulation of building elements	Spec F5.5	N/A	N/A
AS 1273	1991	Unplasticized PVC (UPVC) downpipe and fittings for rainwater	N/A	3.5.3.2	N/A
AS 1288	2006	Glass in buildings — Selection and	B1.4 , Spec C2.5 , Spec C3.4	3.6.0 , 3.6.1 , 3.6.3 ,	N/A

Referenced Documents

No.	Date	Title	Volume One	Volume Two	Volume Three
		installation (incorporating amendments 1, 2 and 3)			
AS 1289.6.3.3	1997	Methods of testing soils for engineering purposes — Method 6.3.3: Soil strength and consolidation tests — Determination of the penetration resistance of a soil — Perth sand penetrometer test (incorporating amendment 1)	N/A	3.2.2.2	N/A
AS 1397	2011	Continuous hot-dip metallic coated steel sheet and strip — Coatings of zinc and zinc alloyed with aluminium and magnesium (incorporating amendment 1)	N/A	3.5.1.2	N/A
AS 1428 Part 1	2009	Design for access and mobility — General requirements for access — New building work (incorporating amendments 1 and 2)	D2.10 , D2.15 , D2.17 , D3.1 , D3.2 , D3.3 , D3.6 , D3.9 , D3.10 , D3.12 , Spec D3.10 , E3.8 , F2.4 , G4.5 , Schedule 3	Schedule 3	Schedule 3 , E1.2
AS 1428 Part 1	2001	Design for access and mobility — General requirements for access — New building work	H2.7 , H2.8 , H2.10 , H2.15	N/A	E1.2
AS 1428 Part 1 (Supplement 1)	1993	Design for access and mobility — General requirements for access — Buildings — Commentary	H2.2	N/A	N/A
AS 1428 Part 2	1992	Design for access and mobility — Enhanced and additional requirements — Buildings and facilities	H2.2 , H2.3 , H2.4 , H2.5 , H2.7 , H2.10 , H2.11 , H2.12 , H2.13 , H2.14	N/A	E1.2
AS 1428 Part 4	1992	Design for access and mobility — Tactile ground surface indicators for the orientation of people with vision impairment	H2.11	N/A	N/A
AS/NZS 1428 Part 4.1	2009	Design for access and mobility — Means to assist the orientation of people with vision impairment — Tactile ground surface indicators (incorporating	D3.8	N/A	N/A

Referenced Documents

No.	Date	Title	Volume One	Volume Two	Volume Three
		amendments 1 and 2)			
AS 1530 Part 1	1994	Methods for fire tests on building materials, components and structures — Combustibility test for materials See Note 2	Schedule 3	Schedule 3	Schedule 3
AS 1530 Part 2	1993	Methods for fire tests on building materials, components and structures — Test for flammability of materials (incorporating amendment 1) See Note 2	Schedule 3	Schedule 3	Schedule 3
AS/NZS 1530 Part 3	1999	Methods for fire tests on building materials, components and structures — Simultaneous determination of ignitability, flame propagation, heat release and smoke release	Schedule 3 , Schedule 6	Schedule 3 , Schedule 6	Schedule 3 , Schedule 6
AS 1530 Part 4	2014	Methods for fire tests on building materials, components and structures — Fire-resistance tests for elements of construction See Note 2	A5.6 , C3.15 , C3.16 , Spec C1.13 , Spec C1.13a , Spec C3.15 , Spec D1.12 , Schedule 3 , Schedule 6	A5.6 , 3.7.3.3 , Schedule 3 , Schedule 6	A5.6 , Schedule 3 , Schedule 6
AS 1562 Part 1	2018	Design and installation of sheet roof and wall cladding — Metal See Note 3	B1.4 , F1.5	3.5.1.0 , 3.5.5.0	N/A
AS/NZS 1562 Part 2	1999	Design and installation of sheet roof and wall cladding — Corrugated fibre-reinforced cement	F1.5	N/A	N/A
AS/NZS 1562 Part 3	1996	Design and installation of sheet roof and wall cladding — Plastic	B1.4 , F1.5	3.5.1.0	N/A
AS 1657	2018	Fixed platforms, walkways, stairways and ladders — Design, construction and installation	D1.16 , D1.17 , D2.18 , H1.6 , H3.5	N/A	N/A
AS/NZS 1664 Part 1	1997	Aluminium structures — Limit state design (incorporating amendment 1)	B1.4	3.0.4	N/A
AS/NZS 1664 Part 2	1997	Aluminium structures — Allowable stress design (incorporating	B1.4	3.0.4	N/A

Referenced Documents

No.	Date	Title	Volume One	Volume Two	Volume Three
		amendment 1)			
AS 1668 Part 1	2015	The use of ventilation and air conditioning in buildings — Fire and smoke control in buildings (incorporating amendment 1)	C2.12, C3.15, Spec C2.5, D1.7, Spec E1.8, E2.2, E2.3, F4.12, Spec E2.2b, Spec G3.8	N/A	N/A
AS 1668 Part 2	2012	The use of ventilation and airconditioning in buildings — Mechanical ventilation in buildings (incorporating amendments 1 and 2)	E2.3, FV4.1, F4.5, F4.11, F4.12, J5.3	V2.4.5, 3.8.5.0	N/A
AS 1668 Part 4	2012	The use of ventilation and airconditioning in buildings — Natural ventilation of buildings	F4.11	N/A	N/A
AS 1670 Part 1	2018	Fire detection, warning, control and intercom systems — System design, installation and commissioning — Fire See Note 4	C3.5, C3.6, C3.7, C3.8, C3.11, D2.21, E2.3, G4.8, Spec C3.4, E2.2, Spec E2.2a, Spec E2.2d, Spec G3.8	3.7.5.2, 3.7.5.6	N/A
AS 1670 Part 3	2018	Fire detection, warning, control and intercom systems — System design, installation and commissioning — Fire alarm monitoring See Note 4	Spec E2.2a, Spec E2.2d	N/A	N/A
AS 1670 Part 4	2018	Fire detection, warning, control and intercom systems — System design, installation and commissioning — Emergency warning and intercom systems See Note 4	EV3.2, E4.9, Spec G3.8	N/A	N/A
AS/NZS 1680 Part 0	2009	Interior lighting — Safe movement	F4.4	3.8.4.3	N/A
AS 1684 Part 2	2010	Residential timber-framed construction — Non-cyclonic areas (incorporating amendments 1 and 2)	B1.4, B1.5, F1.12	3.0.5, 3.2.5.6, 3.4.0.2, 3.4.1.2, 3.4.3.0, 3.5.4.2, 3.5.4.3, 3.5.4.4	N/A
AS 1684 Part 3	2010	Residential timber-framed construction — Cyclonic areas (incorporating amendment 1)	B1.4, B1.5, F1.12	3.0.5, 3.2.5.6, 3.4.0.2, 3.4.1.2, 3.4.3.0, 3.5.4.2, 3.5.4.3, 3.5.4.4	N/A
AS 1684 Part 4	2010	Residential timber-framed construction — Simplified — Non-cyclonic areas (incorporating amendment 1)	B1.4, B1.5, F1.12	3.0.5, 3.2.5.6, 3.4.0.2, 3.4.1.2, 3.4.3.0, 3.5.4.2, 3.5.4.3, 3.5.4.4	N/A

Referenced Documents

No.	Date	Title	Volume One	Volume Two	Volume Three
AS 1720 Part 1	2010	Timber structures — Design methods (incorporating amendments 1, 2 and 3)	BV1, B1.4	V2.1.1, 3.4.3.0	N/A
AS 1720 Part 4	2006	Timber structures — Fire resistance for structural adequacy of timber members	Schedule 5	Schedule 5	Schedule 5
AS 1720 Part 5	2015	Timber structures — Nailplated timber roof trusses	B1.4	3.4.3.0	N/A
AS 1735 Part 11	1986	Lifts, escalators and moving walks — Fire-rated landing doors	C3.10	N/A	N/A
AS 1735 Part 12	1999	Lifts, escalators and moving walks — Facilities for persons with disabilities (incorporating amendment 1)	E3.6, H2.6	N/A	N/A
AS/NZS 1859 Part 4	2018	Reconstituted wood-based panels — Specifications — Wet process fibreboard See Note 5	N/A	3.5.4.3, 3.5.4.4	N/A
AS 1860 Part 2	2006	Particleboard flooring — Installation (incorporating amendment 1)	B1.4	3.4.3.0	N/A
AS 1905 Part 1	2015	Components for the protection of openings in fire-resistant walls — Fire-resistant doorsets (incorporating amendment 1)	C3.6, Spec C3.4	N/A	N/A
AS 1905 Part 2	2005	Components for the protection of openings in fire-resistant walls — Fire-resistant roller shutters	Spec C3.4	N/A	N/A
AS 1926 Part 1	2012	Swimming pool safety — Safety barriers for swimming pools	G1.1, G1.3	3.10.1.0	N/A
AS 1926 Part 2	2007	Swimming pool safety — Location of safety barriers for swimming pools (incorporating amendments 1 and 2)	G1.1	3.10.1.0	N/A
AS 1926 Part 3	2010	Swimming pool safety — Water recirculation systems (incorporating amendment 1)	G1.1	3.10.1.0	N/A
AS 2047	2014	Windows and external glazed doors in buildings (incorporating amendments 1 and 2) See Note 6	B1.4, FV1.1, F1.13, J3.4	V2.2.1, 3.6.0, 3.6.1, 3.12.3.3	N/A

Referenced Documents

No.	Date	Title	Volume One	Volume Two	Volume Three
AS 2049	2002	Roof tiles (incorporating amendment 1)	F1.5	3.5.2.1	N/A
AS 2050	2018	Installation of roof tiles	B1.4 , F1.5	3.5.2.0 , 3.5.2.2	N/A
AS 2118 Part 1	2017	Automatic fire sprinkler systems — General systems (incorporating amendment 1)	CV3 , E1.3 , Spec E1.5 , Spec E1.5a	N/A	N/A
AS 2118 Part 4	2012	Automatic fire sprinkler systems — Sprinkler protection for accommodation buildings not exceeding four storeys in height	E1.3 , Spec E1.5 , Spec E1.5a	N/A	N/A
AS 2118 Part 6	2012	Automatic fire sprinkler systems — Combined sprinkler and hydrant systems in multistorey buildings	E1.3 , Spec E1.5	N/A	N/A
AS 2159	2009	Piling — Design and installation (incorporating amendment 1)	B1.4	3.2.0	N/A
AS/NZS 2179 Part 1	2014	Specifications for rainwater goods, accessories and fasteners — Metal shape or sheet rainwater goods, and metal accessories and fasteners	N/A	3.5.3.2	N/A
AS/NZS 2269 Part 0	2012	Plywood — Structural — Specifications (incorporating amendment 1)	N/A	3.5.4.4	N/A
AS/NZS 2293 Part 1	2018	Emergency lighting and exit signs for buildings — System design, installation and operation	E4.4 , E4.8 , Spec E4.8 , H3.15	N/A	N/A
AS/NZS 2327	2017	Composite structures — Composite steel-concrete construction in buildings	B1.4 , Schedule 5	3.0.4 , Schedule 5	Schedule 5
AS 2419 Part 1	2005	Fire hydrant installations — System design, installation and commissioning (incorporating amendment 1)	C2.12 , E1.3 , Spec E1.5a , H3.9	N/A	N/A
AS 2441	2005	Installation of fire hose reels (incorporating amendment 1)	E1.4	N/A	N/A
AS 2444	2001	Portable fire extinguishers and fire blankets — Selection and location	E1.6 , H3.11	N/A	N/A
AS 2665	2001	Smoke/heat venting	Spec E2.2c , Spec	N/A	N/A

Referenced Documents

No.	Date	Title	Volume One	Volume Two	Volume Three
		systems — Design, installation and commissioning	G3.8		
AS/NZS 2699 Part 1	2000	Built-in components for masonry construction — Wall ties	N/A	3.3.5.10	N/A
AS/NZS 2699 Part 3	2002	Built-in components for masonry construction — Lintels and shelf angles (durability requirements)	N/A	3.3.5.12	N/A
AS 2870	2011	Residential slabs and footings	F1.10	3.1.1.0, 3.1.3.4, 3.1.4.4, 3.2.0, 3.2.1, 3.2.2.4, 3.2.2.6, 3.2.3.2, 3.2.4.1, 3.2.5, 3.2.5.2, 3.2.5.6	N/A
AS/NZS 2890 Part 6	2009	Parking facilities — Off-street parking for people with disabilities	D3.5	N/A	N/A
AS/NZS 2904	1995	Damp-proof courses and flashings (incorporating amendments 1 and 2)	F1.9	3.3.5.7, 3.5.4.6, 3.10.6.3	N/A
AS/NZS 2908 Part 1	2000	Cellulose-cement products — Corrugated sheets	B1.4, F1.5	N/A	N/A
AS/NZS 2908 Part 2	2000	Cellulose-cement products — Flat sheets	Schedule 3	3.5.4.3, 3.5.4.4, 3.5.4.5, Schedule 3	Schedule 3
AS/NZS 2918	2018	Domestic solid fuel burning appliances — Installation See Note 11	G2.2	3.10.7.0, 3.10.7.4, 3.10.7.5	N/A
AS/NZS 3013	2005	Electrical installations — Classification of the fire and mechanical performance of wiring system elements	C2.13	N/A	N/A
AS/NZS 3500 Part 0	2003	Plumbing and drainage — Glossary of terms	A1.0	A1.0	A1.0
AS/NZS 3500 Part 1	2018	Plumbing and drainage — Water services	N/A	N/A	B1.4, B3.3, B4.2, B5.2, B5.3, B5.4, BS5.1.2, B6.4, B6.5,
AS/NZS 3500 Part 2	2018	Plumbing and drainage — Sanitary plumbing and drainage	N/A	N/A	C1.3, CV2.2, C2.3, C2.4,
AS/NZS 3500 Part 3	2018	Plumbing and drainage — Stormwater drainage	F1.1	3.1.3.0, 3.1.3.4, 3.5.3.0, 3.5.3.3, 3.5.3.5	N/A
AS/NZS 3500 Part 4	2018	Plumbing and drainage — Heated water services (incorporating amendment 1)	N/A	N/A	B2.2, B2.6, B2.7, B2.8, B2.9
AS 3600	2018	Concrete structures (incorporating	BV1, B1.4, Schedule 5	V2.1.1, 3.0.4, 3.1.4.4, 3.2.2.4,	Schedule 5

Referenced Documents

No.	Date	Title	Volume One	Volume Two	Volume Three
		amendment 1)		3.2.3.1, 3.2.5.6, Schedule 5	
AS 3660 Part 1	2014	Termite management — New building work (incorporating amendment 1)	B1.4, F1.9	3.1.4.2, 3.1.4.3	N/A
AS 3660 Part 3	2014	Termite management — Assessment criteria for termite management systems	N/A	3.1.4.3	N/A
AS/NZS 3666 Part 1	2011	Air-handling and water systems of buildings — Microbial control — Design, installation and commissioning	F2.7, F4.5	N/A	N/A
AS 3700	2018	Masonry structures	B1.4, Schedule 5	3.3.1.0, 3.3.2.0, 3.3.3.0, 3.3.4.0, 3.3.5.0, 3.3.5.4, 3.3.6.0, 3.3.6.1, Schedule 5	Schedule 5
AS 3740	2010	Waterproofing of domestic wet areas (incorporating amendment 1)	F1.7	3.8.1.2	N/A
AS 3786	2014	Smoke alarms using scattered light, transmitted light or ionization (incorporating amendment 1 and 2) See Note 7	Spec E2.2a	3.7.5.2, 3.7.5.6	N/A
AS/NZS 3823 Part 1.2	2012	Performance of electrical appliances — Airconditioners and heat pumps — Ducted airconditioners and air-to-air heat pumps — Testing and rating for performance	Spec JVa, J5.11	N/A	N/A
AS 3959	2018	Construction of buildings in bushfire-prone areas	G5.2	3.10.5.0	N/A
AS/NZS 4020	2018	Testing of products for use in contact with drinking water See Note 8	A5.3	A5.3	A5.3, A5.6
AS 4055	2012	Wind loads for housing (incorporating amendment 1)	Schedule 3	3.0.3, Schedule 3	Schedule 3
AS 4072 Part 1	2005	Components for the protection of openings in fire-resistant separating elements — Service penetrations and control joints (incorporating amendment 1) See Note 9	C3.15	3.7.3.3	N/A
AS 4100	1998	Steel structures	B1.4, Schedule 5	3.2.5.6, 3.3.5.12,	Schedule 5

Referenced Documents

No.	Date	Title	Volume One	Volume Two	Volume Three
		(incorporating amendment 1)		3.4.2.0, 3.4.4.0, 3.10.6.2, Schedule 5	
AS/NZS 4200 Part 1	2017	Pliable building membranes and underlays — Materials	F1.6, F6.2, Schedule 3	3.5.2.4, 3.5.4.2, 3.5.4.8, 3.8.7.2, Schedule 3	Schedule 3
AS 4200 Part 2	2017	Pliable building membranes and underlays — Installation requirements (incorporating amendment 1)	F1.6, F6.2	3.8.7.2	N/A
AS/NZS 4234	2008	Heated water systems — Calculation of energy consumption (incorporating amendments 1, 2 and 3)	N/A	N/A	BV2.1, B2.2
AS 4254 Part 1	2012	Ductwork for air-handling systems in buildings — Flexible duct	Spec C1.10, J5.6	3.7.1.2, 3.12.5.3	N/A
AS 4254 Part 2	2012	Ductwork for air-handling systems in buildings — Rigid duct	Spec C1.10, J5.4, J5.6	3.12.5.3	N/A
AS/NZS 4256 Part 1	1994	Plastic roof and wall cladding materials — General requirements	F1.5	N/A	N/A
AS/NZS 4256 Part 2	1994	Plastic roof and wall cladding materials — Unplasticized polyvinyl chloride (uPVC) building sheets	F1.5	N/A	N/A
AS/NZS 4256 Part 3	1994	Plastic roof and wall cladding materials — Glass fibre reinforced polyester (GRP)	F1.5	N/A	N/A
AS/NZS 4256 Part 5	1996	Plastic roof and wall cladding materials — Polycarbonate	F1.5	N/A	N/A
AS/NZS 4284	2008	Testing of building facades	FV1.1	V2.2.1	N/A
AS/NZS 4505	2012	Garage doors and other large access doors (incorporating amendment 1)	B1.4	3.0.4	N/A
AS 4552	2005	Gas fired water heaters for hot water supply and/or central heating	N/A	N/A	B2.2
AS 4586	2013	Slip resistance classification of new pedestrian surface materials (incorporating amendment 1) See Note 10	D2.10, D2.13, D2.14, Spec F2.9	3.9.1.4	N/A
AS 4597	1999	Installation of roof slates and shingles (Non-interlocking type)	B1.4, F1.5	3.5.2.0	N/A

Referenced Documents

No.	Date	Title	Volume One	Volume Two	Volume Three
AS/NZS 4600	2018	Cold-formed steel structures	B1.4, Schedule 5	3.4.2.0, 3.4.4.0, Schedule 5	Schedule 5
AS 4654 Part 1	2012	Waterproofing membranes for external above-ground use — Materials	F1.4	3.8.1.3	N/A
AS 4654 Part 2	2012	Waterproofing membranes for external above-ground use — Design and installation	F1.4	3.8.1.3	N/A
AS 4678	2002	Earth-retaining structures	N/A	3.1.2.0	N/A
AS 4773 Part 1	2015	Masonry in small buildings — Design (incorporating amendment 1)	N/A	3.3.1.0, 3.3.2.0, 3.3.3.0, 3.3.4.0, 3.3.5.0, 3.3.5.4, 3.3.6.0	N/A
AS 4773 Part 2	2015	Masonry in small buildings — Construction	N/A	3.3.1.0, 3.3.2.0, 3.3.3.0, 3.3.4.0, 3.3.5.0, 3.3.5.4, 3.3.6.0	N/A
AS/NZS 4859 Part 1	2018	Thermal insulation materials for buildings — General criteria and technical provisions	J1.2, J5.5, J5.8	3.12.1.1, 3.12.1.5, 3.12.5.1, 3.12.5.2, 3.12.5.3	N/A
AS/NZS 4859 Part 2	2018	Thermal insulation materials for buildings — Design	J1.2, Spec J1.5a	N/A	N/A
AS 5113	2016	Classification of external walls of buildings based on reaction-to-fire performance (incorporating amendment 1)	CV3	N/A	N/A
AS 5146 Part 1	2015	Reinforced autoclaved aerated concrete — Structures (incorporating amendment 1)	B1.4	3.5.4.0	N/A
AS 5216	2018	Design of post-installed and cast-in fastenings in concrete	B1.4	3.0.4	N/A
AS 5637 Part 1	2015	Determination of fire hazard properties — Wall and ceiling linings	Spec C1.10, Schedule 3	Schedule 3	Schedule 3
AS ISO 9239 Part 1	2003	Reaction to fire tests for floorings — Determination of the burning behaviour using a radiant heat source	Schedule 3	Schedule 3	Schedule 3
AS/NZS ISO 9972	2015	Thermal performance of buildings — Determination of air permeability of buildings — Fan pressurization method	JV4	V2.6.2.3	N/A
AIRAH-DA09	1998	Air conditioning load estimation	Spec JVc	N/A	N/A
AIRAH-DA28	2011	Building management	Spec JVb	N/A	N/A

Referenced Documents

No.	Date	Title	Volume One	Volume Two	Volume Three
		and control systems			
ANSI/ASHRAE Standard 55	2013	Thermal environmental conditions for human occupancy	Schedule 3	Schedule 3	Schedule 3
ANSI/ASHRAE Standard 140	2007	Standard method of test for the evaluation of building energy analysis computer programs	JV1, JV2, JV3	V2.6.2.2	N/A
ASTM E2073-10	2010	Standard Test Method for Photopic Luminance of Photoluminescent (Phosphorescent) Markings	Spec E4.8	N/A	N/A
ASTM E72-15	2015	Standard Test Methods of Conducting Strength Tests of Panels for Building Construction	Spec C1.8	N/A	N/A
ASTM E695-03	2003	Standard Test Method of Measuring Relative Resistance of Wall, Floor and Roof Construction to Impact Loading	Spec C1.8	N/A	N/A
ASTM E903	2012	Standard Test Method for Solar Absorptance, Reflectance, and Transmittance of Materials Using Integrating Spheres	N/A	3.12.1.2	N/A
AHRI 460	2005	Performance rating of remote mechanical-draft air-cooled refrigerant condensers	J5.12	N/A	N/A
AHRI 551/591	2015	Performance rating of water-chilling and heat pump water-heating packages using the vapor compression cycle.	Spec JV a, J5.10	N/A	N/A
ABCB	2011	Protocol for Structural Software, Version 2011.2	B1.5	3.0.5, 3.4.0.2	N/A
ABCB	2012	Standard for Construction of Buildings in Flood Hazard Areas, Version 2012.3	B1.6	3.10.3.0	N/A
ABCB	2019	Standard for NatHERS Heating and Cooling Load Limits, Version 2019.1	J0.2	3.12.0.1	N/A
CIBSE Guide A	2015	Environmental design	Spec JV b, Spec JV c, J1.2, J1.6	N/A	N/A
Disability Standards for Accessible Public Transport	2002		F2.9, H2.1	N/A	N/A

Referenced Documents

No.	Date	Title	Volume One	Volume Two	Volume Three
Education and Care Services National Law Act (Vic)	2010		Schedule 3	Schedule 3	Schedule 3
European Union Commission Regulation 547/2012	2012	Ecodesign requirements for water pumps	J5.7	N/A	N/A
European Union Commission Regulation 622/Annex II, point 2	2012	Eco-design requirements for glandless standalone circulators and glandless circulators integrated in products	J5.7	N/A	N/A
FPAA101D	2018	Automatic Fire Sprinkler System Design and Installation — Drinking Water Supply	CV3, C1.5, C1.13, C2.1, C2.6, C2.7, C3.5, C3.6, C3.7, C3.8, C3.11, Spec C1.1, Spec C1.10, D1.3, D1.12, D2.21, D2.25, E1.3, Spec E1.5, Spec E1.5a, E2.2, Spec E2.2a, G3.1, G3.6, Spec G3.8, H1.2	N/A	B4.2
FPAA101H	2018	Automatic Fire Sprinkler System Design and Installation — Hydrant Water Supply	CV3, C1.5, C1.13, C2.1, C2.6, C2.7, Spec C1.1, Spec C1.10, E1.3, Spec E1.5, Spec E1.5a, E2.2, Spec E2.2a, G3.1, G3.6, Spec G3.8, H1.2	N/A	B4.2
ISO 140 Part 6	1998E	Acoustics — Measurement of sound insulation in buildings and of building elements — Laboratory measurements of impact sound insulation of floors	Spec F5.5	N/A	N/A
ISO 540	2008	Hard coal and coke — Determination of ash fusibility	Spec C3.15	N/A	N/A
ISO 8336	1993E	Fibre-cement flat sheets	Schedule 3	3.5.4.3, 3.5.4.4, 3.5.4.5, Schedule 3	Schedule 3
ISO 25745 Part 2	2015	Energy performance of lifts, escalators and moving walks: Energy calculation and classification for lifts (elevators)	J6.7	N/A	N/A
NASH Standard	2014	Steel Framed	N/A	3.10.5.0	N/A

Referenced Documents

No.	Date	Title	Volume One	Volume Two	Volume Three
		Construction in Bushfire Areas (incorporating amendment A)			
NASH Standard Part 1	2005	Residential and Low-Rise Steel Framing — Design Criteria (incorporating amendments A, B and C)	B1.4	3.4.2.0	N/A
NASH Standard Part 2	2014	Residential and Low-Rise Steel Framing — Design Solutions (incorporating amendment A)	B1.4, B1.5, F1.12	3.0.5, 3.4.0.2, 3.4.1.2, 3.4.2.0, 3.5.4.4	N/A
N/A	N/A	Northern Territory Deemed to Comply Standards Manual	N/A	3.0.4	N/A
TN 61		Cement Concrete and Aggregates Australia — Technical note — Articulated walling	N/A	3.2.1	N/A

Notes associated with [Table 1](#):

- (1) For AS/NZS ISO 717.1:
 - (a) Test reports based on AS 1276—1979 and issued prior to AS/NZS 1276.1—1999 being referenced in the NCC remain valid.
 - (b) The STC values in reports based on AS 1276—1979 shall be considered to be equivalent to R_w values.
 - (c) Test reports based on AS/NZS 1276.1 prepared after the NCC reference date for AS/NZS 1276.1—1999 must be based on that version.
 - (d) Test reports based on ISO 717-1—1996 and issued prior to AS/NZS ISO 717.1—2004 being referenced in the NCC remain valid.
 - (e) Reports based on AS/NZS ISO 717.1 relating to tests carried out after the NCC reference date for AS/NZS ISO 717.1—2004 must relate to the amended Standard.
- (2) For AS 1530 Parts 1 to 4:
 - (a) Until 1 May 2022, subject to the note to AS 4072.1, reports relating to tests carried out under earlier editions of AS 1530 Parts 1 to 4 remain valid.
 - (b) Reports relating to tests carried out after the date of an amendment to a Standard must relate to the amended Standard.
- (3) For AS 1562.1, tests carried out based on AS 1562.1—1992 and issued prior to AS 1562.1—2018 being referenced in the NCC remain valid. Reports relating to tests carried out after the NCC reference date for AS 1562.1 must relate to the revised Standard.
- (4) For AS 1670.1, AS 1670.3 and AS 1670.4:
 - (a) Notwithstanding [A4.0\(5\)](#), until 1 May 2022 either the current edition or the previous editions of the documents listed in Table 1.8 of AS 1670.1, AS 1670.3 and AS 1670.4 may be used to meet the requirements of AS 1670.1, AS 1670.3 and AS 1670.4 as applicable.
 - (b) From 1 May 2022 [A4.0\(5\)](#) applies and only the edition of the documents listed in Table 1.8 of AS 1670.1, AS 1670.3 and AS 1670.4 that existed at the time of publication of the primary document may be used.
- (5) For AS/NZS 1859.4, the 2004 edition has been retained for a transitional period ending on 30 April 2020.
- (6) For AS 2047:
 - (a) Tests carried out under earlier editions of AS 2047 remain valid.
 - (b) Reports based on AS 2047 relating to tests carried out after the NCC reference date for AS 2047—2014

Referenced Documents

Amendment 2 must relate to the amended Standard.

- (7) For AS 3786:
 - (a) Tests carried out under AS 3786—2014 Amendment 1 remain valid.
 - (b) Reports based on AS 3786 relating to tests carried out after the NCC reference date for AS 3786—2014 Amendment 2 must relate to the amended Standard.
- (8) Test reports based on the 2005 edition of AS/NZS 4020 will continue to be accepted until 1 May 2024. Test reports prepared after the NCC reference date for the 2018 edition of AS/NZS 4020 must be based on the 2018 edition.
- (9) For AS 4072.1, until 1 May 2022, systems tested to AS 1530.4 prior to 1 January 1995 need not be retested to comply with the provisions in AS 4072.1.
- (10) For AS 4586:
 - (a) Test reports based on the 2004 edition of AS/NZS 4586 and issued prior to the 2013 edition of AS 4586 being referenced in the NCC remain valid.
 - (b) Test reports prepared after the NCC reference date of the 2013 edition of AS 4586 must be based on that version.
 - (c) For the purposes of assessing compliance, the slip-resistance classifications of V, W and X in reports based on the 2004 edition of AS/NZS 4586 may be considered to be equivalent to slip-resistance classifications of P5, P4 and P3 respectively in the 2013 edition of AS 4586.
 - (d) Test reports based on Appendix D of AS 4586—2013 and issued prior to the NCC reference date for AS 4586—2013 (incorporating Amendment 1) remain valid.
 - (e) Test reports based on Appendix D of AS 4586—2013 and prepared after the NCC reference date for AS 4586—2013 (incorporating Amendment 1) must be based on that version.
- (11) Tests carried out based on AS/NZS 2918—2001 and issued prior to AS/NZS 2918—2018 being referenced in the BCA remain valid. Reports relating to tests carried out after the NCC reference date for AS/NZS 2918 must relate to the revised Standard.

State and Territory variations for Volume One—Schedule of referenced documents

ACT, NSW, NT, Qld, SA, Tas, Vic

State and Territory variations for Volume Two—Schedule of referenced documents

ACT, NSW, NT, Qld, SA, Tas, Vic, WA

State and Territory variations for Volume Three—Schedule of referenced documents

ACT, SA, Tas

Fire-resistance of Building Elements

Schedule 5 Fire-resistance of building elements

Schedule 5 Fire-resistance of Building Elements

Schedule 5 Fire-resistance of building elements

1. Scope
2. Rating
3. FRLs determined by calculation
4. Interchangeable materials
5. Columns covered with lightweight construction
6. Non-loadbearing elements

Schedule 5 Fire-resistance of building elements

1. Scope

This Schedule sets out the procedures for determining the FRL of building elements.

2. Rating

A building element meets the requirements of this Schedule if—

- (a) it is listed in, and complies with [Table 1](#) of this Schedule; or
- (b) it is identical with a prototype that has been submitted to the *Standard Fire Test*, or an equivalent or more severe test, and the FRL achieved by the prototype without the assistance of an active fire suppression system is confirmed in a report from an *Accredited Testing Laboratory* which—
 - (i) describes the method and conditions of the test and the form of construction of the tested prototype in full; and
 - (ii) certifies that the application of restraint to the prototype complied with the *Standard Fire Test*; or
- (c) it differs in only a minor degree from a prototype tested under (b) and the FRL attributed to the building element is confirmed in a report from an *Accredited Testing Laboratory* which—
 - (i) certifies that the building element is capable of achieving the FRL despite the minor departures from the tested prototype; and
 - (ii) describes the materials, construction and conditions of restraint which are necessary to achieve the FRL; or
- (d) it is designed to achieve the FRL in accordance with—
 - (i) AS/NZS 2327, AS 4100 and AS/NZS 4600 if it is a steel or composite structure; or
 - (ii) AS 3600 if it is a concrete structure; or
 - (iii) AS 1720.4 if it is a timber element other than *fire-protected timber*; or
 - (iv) AS 3700 if it is a masonry structure; or
- (e) the FRL is determined by calculation based on the performance of a prototype in the *Standard Fire Test* and confirmed in a report in accordance with [Clause 3](#); or
- (f) for *fire-protected timber*, it complies with [Specification C1.13a](#) where applicable.

3. FRLs determined by calculation

If the FRL of a building element is determined by calculation based on a tested prototype—

- (a) the building element may vary from the prototype in relation to—
 - (i) length and height if it is a wall; and
 - (ii) height if it is a column; and
 - (iii) span if it is a floor, roof or beam; and
 - (iv) conditions of support; and
 - (v) to a minor degree, cross-section and components; and
- (b) the report must demonstrate by calculation that the building element would achieve the FRL if it is subjected to the regime of the *Standard Fire Test* in relation to—
 - (i) *structural adequacy* (including deflection); and
 - (ii) *integrity*; and
 - (iii) *insulation*; and
- (c) the calculations must take into account—
 - (i) the temperature reached by the components of the prototype and their effects on strength and modulus of elasticity; and

Fire-resistance of Building Elements

- (ii) appropriate features of the building element such as support, restraint, cross-sectional shape, length, height, span, slenderness ratio, reinforcement, ratio of surface area to mass per unit length, and fire protection; and
- (iii) features of the prototype that influenced its performance in the *Standard Fire Test* although these features may not have been taken into account in the design for dead and live load; and
- (iv) features of the conditions of test, the manner of support and the position of the prototype during the test, that might not be reproduced in the building element if it is exposed to fire; and
- (v) the design load of the building element in comparison with the tested prototype.

4. Interchangeable materials

- (a) Concrete and plaster — An FRL achieved with any material of Group A, B, C, D or E as an ingredient in concrete or plaster, applies equally when any other material of the same group is used in the same proportions:
- Group A: Any portland cement.
 - Group B: Any lime.
 - Group C: Any dense sand.
 - Group D: Any dense calcareous aggregate, including any limestone or any calcareous gravel.
 - Group E: Any dense siliceous aggregate, including any basalt, diorite, dolerite, granite, granodiorite or trachyte.
- (b) Perlite and vermiculite — An FRL achieved with either gypsum-perlite plaster or gypsum-vermiculite plaster applies equally for each plaster.

5. Columns covered with lightweight construction

If the *fire-resisting* covering of a steel column is *lightweight construction*, the construction must comply with C1.8 and C3.17.

6. Non-loadbearing elements

If a non-*loadbearing* element is able to be used for a purpose where the *Deemed-to-Satisfy Provisions* prescribe an FRL for *structural adequacy*, *integrity* and *insulation*, that non-*loadbearing* element need not comply with the *structural adequacy* criteria.

Table 1 FRLs Deemed to be achieved by certain building element

Building element	Minimum thickness (mm) of principal material for FRLs					Annexure reference
	60/60/60	90/90/90	120/120/120	180/180/180	240/240/240	
Wall						
	60/60/60	90/90/90	120/120/120	180/180/180	240/240/240	Clause
Masonry						
Ashlar	–	–	–	–	300	1, 2, 5, 6
Calcium silicate		see 2(d)(iv) of this Specification				
Concrete		see 2(d)(iv) of this Specification				
Fired clay (inc terracotta)		see 2(d)(iv) of this Specification				
Concrete						
No-fines	–	–	–	150	170	1, 5, 6
Prestressed		see 2(d)(ii) of this Specification				
Reinforced		see 2(d)(ii) of this Specification				
Plain	–	–	–	150	170	1, 5, 6
Solid gypsum blocks	75	90	100	110	125	1, 5, 6
Gypsum — perlite or Gypsum vermiculite-plaster on metal lath and channel (non-<i>loadbearing</i> walls only)	50	50	65	–	–	1, 5, 7
Concrete column						
	60/60/60	90/90/90	120/120/120	180/180/180	240/240/240	Clause
Prestressed		see 2(d)(ii) of this Specification				

Fire-resistance of Building Elements

Building element	Minimum thickness (mm) of principal material for FRLs					Annexure reference
Reinforced	see 2(d)(ii) of this Specification					
Hot-rolled steel column						
	60/60/60	90/90/90	120/120/120	180/180/180	240/240/240	Clause
(inc. a fabricated column) exposed on no more than 3 sides:						8
Fire protection of Concrete — Cast in-situ— <i>loadbearing</i>	25	30	40	55	75	9, 11, 12
non- <i>loadbearing</i> — unplastered	25	30	40	50	65	9, 11, 12
plastered 13 mm—	25	25	30	40	50	1, 6, 9, 11, 12
Gypsum — Cast in-situ Gypsum — perlite or Gypsum-vermiculite plaster	—	—	—	—	50	9, 11, 12
sprayed to contour	20	25	35	50	55	1, 11
sprayed on metal lath	20	20	25	35	45	1, 7
Hot-rolled steel column						
	60/60/60	90/90/90	120/120/120	180/180/180	240/240/240	Clause
(inc. a fabricated column) exposed on no more than 3 sides and with column spaces filled:						8, 9
Fire protection of— Solid calcium-silicate masonry	50	50	50	50	65	1, 3, 11, 12
Solid clay masonry	50	50	50	65	90	1, 3, 11, 12
Solid concrete masonry	50	50	50	65	90	1, 3, 11, 12
Solid gypsum blocks	50	50	50	50	65	1, 3, 11, 12
Hollow terracotta blocks plastered 13 mm	50	50	50	65	90	1, 3, 6, 10., 11, 12
Hot-rolled steel column						
	60/60/60	90/90/90	120/120/120	180/180/180	240/240/240	Clause
(inc. a fabricated column) exposed on no more than 3 sides and with column spaces unfilled:						8
Fire protection of— Solid calcium- silicate masonry	50	50	50	—	—	1, 3, 11, 12
Solid clay masonry	50	50	65	—	—	1, 3, 11, 12
Solid concrete masonry	50	50	65	—	—	1, 3, 11, 12
Solid gypsum blocks	50	50	50	—	—	1, 3, 11, 12
Hollow terracotta blocks— plastered 13 mm	50	50	65	—	—	1, 3, 6, 10, 11, 12
Hot-rolled steel column						
	60/-/-	90/-/-	120/-/-	180/-/-	240/-/-	Clause
(inc. a fabricated column) exposed on 4 sides:						8
Fire protection of— Concrete — Cast in-situ— <i>loadbearing</i>	25	40	45	65	90	9, 11, 12
non- <i>loadbearing</i> unplastered	25	30	40	50	65	9, 11, 12
plastered 13 mm	25	25	30	40	50	1, 6, 9, 11, 12
Gypsum — Cast in-situ Gypsum-perlite or	—	—	—	—	50	9, 11, 12

Fire-resistance of Building Elements

Building element	Minimum thickness (mm) of principal material for FRLs					Annexure reference
	60/-/-	90/-/-	120/-/-	180/-/-	240/-/-	
Gypsum-vermiculite plaster						
sprayed to contour	25	30	40	55	65	1, 11
sprayed on metal lath	20	20	30	40	50	1, 7
Hot-rolled steel column						
	60/-/-	90/-/-	120/-/-	180/-/-	240/-/-	Clause
(inc. a fabricated column) exposed on 4 sides and with column spaces filled:						8, 9
Fire protection of—						
Solid calcium-silicate masonry	50	50	50	65	75	1, 3, 11, 12
Solid clay masonry	50	50	50	75	100	1, 3, 11, 12
Solid concrete masonry	50	50	50	75	100	1, 3, 11, 12
Solid gypsum blocks	50	50	50	65	75	1, 3, 11, 12
Hollow terracotta blocks— plastered 13 mm	50	50	50	75	100	1, 3, 6, 10, 11, 12
Hot-rolled steel column						
	60/-/-	90/-/-	120/-/-	180/-/-	240/-/-	Clause
(inc. a fabricated column) exposed on 4 sides and with column spaces unfilled:						8
Fire protection of—						
Solid calcium-silicate masonry	50	50	50	—	—	1, 3, 11, 12
Solid clay masonry	50	50	65	—	—	1, 3, 11, 12
Solid concrete masonry	50	50	65	—	—	1, 3, 11, 12
Solid gypsum blocks	50	50	50	—	—	1, 3, 11, 12
Hollow terracotta blocks— plastered 13 mm	50	50	65	—	—	1, 3, 6, 10, 11, 12
Beam						
	60/-/-	90/-/-	120/-/-	180/-/-	240/-/-	Clause
Concrete—						
Prestressed		see 2(d)(ii) of this Specification				
Reinforced		see 2(d)(ii) of this Specification				
Hot-rolled Steel (inc. an open-web joist girder truss etc) exposed on no more than 3 sides:						8
Fire protection of—						
Concrete — Cast in-situ	25	30	40	50	65	11, 12
Gypsum-perlite or Gypsum-vermiculite plaster						
sprayed to contour	20	25	35	50	55	1, 11
sprayed on metal lath	20	20	25	35	45	1, 7
Hot-rolled Steel (inc. an open-web joist girder truss etc) exposed on 4 sides:						8
Fire protection of—						
Concrete — Cast in-situ	25	40	45	65	90	11, 12
Gypsum-perlite or Gypsum-vermiculite plaster—						
sprayed to contour	25	30	40	55	65	1, 11
sprayed on metal lath	20	20	30	40	50	1, 7
Floor, roof or ceiling						
	60/60/60	90/90/90	120/120/120	180/180/180	240/240/240	Clause
Concrete—						
Prestressed		see 2(d)(ii) of this Specification				

Fire-resistance of Building Elements

Building element	Minimum thickness (mm) of principal material for FRLs	Annexure reference
Reinforced	see 2(d)(ii) of this Specification	

Annexure to Table 1

1. Mortar, plaster and plaster reinforcement

1.1 Mortar for masonry

Masonry units of ashlar, calcium silicate, concrete or fired clay (including terracotta blocks) must be laid in cement mortar or composition mortar complying with the relevant provisions of AS 3700.

1.2 Gypsum blocks

Gypsum blocks must be laid in gypsum-sand mortar or lime mortar.

1.3 Gypsum-sand mortar and plaster

Gypsum-sand mortar and gypsum-sand plaster must consist of either—

- (a) not more than 3 parts by volume of sand to 1 part by volume of gypsum; or
- (b) if lime putty is added, not more than 2.5 parts by volume of sand to 1 part by volume of gypsum and not more than 5% of lime putty by volume of the mixed ingredients.

1.4 Gypsum-perlite and gypsum-vermiculite plaster

Gypsum-perlite or gypsum-vermiculite plaster must be applied—

- (a) in either one or 2 coats each in the proportions of 1 m³ of perlite or vermiculite to 640 kg of gypsum if the *required* thickness of the plaster is not more than 25 mm; and
- (b) in 2 coats if the *required* thickness is more than 25 mm, the first in the proportions of 1 m³ of perlite or vermiculite to 800 kg of gypsum and the second in the proportions of 1 m³ of perlite or vermiculite to 530 kg of gypsum.

1.5 Plaster of cement and sand or cement, lime and sand

Plaster prescribed in [Table 1](#) must consist of—

- (a) cement and sand or cement, lime and sand; and
- (b) may be finished with gypsum, gypsum-sand, gypsum-perlite or gypsum-vermiculite plaster or with lime putty.

1.6 Plaster reinforcement

If plaster used as fire protection on walls is more than 19 mm thick—

- (a) it must be reinforced with expanded metal lath that—
 - (i) has a mass per unit area of not less than 1.84 kg/m²; and
 - (ii) has not fewer than 98 meshes per metre; and
 - (iii) is protected against corrosion by galvanising or other suitable method; or
- (b) it must be reinforced with 13 mm x 13 mm x 0.7 mm galvanised steel wire mesh, and with the reinforcement must be securely fixed at a distance from the face of the wall of not less than 1/3 of the total thickness of the plaster.

2. Ashlar stone masonry

Ashlar masonry must not be used in a part of the building containing more than 2 *storeys*, and must not be of—

- (a) aplite, granite, granodiorite, quartz dacite, quartz diorite, quartz porphyrite or quartz porphyry; or
- (b) conglomerate, quartzite or sandstone; or
- (c) chert or flint; or
- (d) limestone or marble.

3. Dimensions of masonry

The thicknesses of masonry of calcium-silicate, concrete and fired clay are calculated as follows:

3.1 Solid units

For masonry in which the amount of perforation or coring of the units does not exceed 25% by volume (based on the overall rectangular shape of the unit) the thickness of the wall must be calculated from the manufacturing dimensions of the units and the specified thickness of the joints between them as appropriate.

3.2 Hollow units

For masonry in which the amount of perforation or coring of the units exceeds 25% by volume (based on the overall rectangular shape of the unit) the thickness of the wall must be calculated from the equivalent thicknesses of the units and the specified thickness of the joints between them as appropriate.

3.3 Equivalent thickness

The equivalent thickness of a masonry unit is calculated by dividing the net volume by the area of one vertical face.

4. * * * * *

This Clause has deliberately been left blank.

5. Height-to-thickness ratio of certain walls

The ratio of height between lateral supports to overall thickness of a wall of ashlar, no-fines concrete, unreinforced concrete, solid gypsum blocks, gypsum-perlite or gypsum-vermiculite plaster on metal lath and channel, must not exceed—

- (a) 20 for a *loadbearing* wall; or
- (b) 27 for a non-*loadbearing* wall.

6. Increase in thickness by plastering

6.1 Walls

If a wall of ashlar, solid gypsum blocks or concrete is plastered on both sides to an equal thickness, the thickness of the wall for the purposes of [Table 1](#) (but not for the purposes of [Annexure Clause 5](#)) may be increased by the thickness of the plaster on one side.

6.2 Columns

Where [Table 1](#) indicates that column-protection is to be plastered, the tabulated thicknesses are those of the principal material. They do not include the thickness of plaster which must be additional to the listed thickness of the material to which it is applied.

7. Gypsum-perlite or gypsum-vermiculite plaster on metal lath

7.1 Walls

In walls fabricated of gypsum-perlite or gypsum-vermiculite plaster on metal lath and channel—

- (a) the lath must be securely wired to each side of 19 mm x 0.44 kg/m steel channels (used as studs) spaced at not more than 400 mm centres; and
- (b) the gypsum-perlite or gypsum-vermiculite plaster must be applied symmetrically to each exposed side of the lath.

7.2 Columns

For the fire protection of steel columns with gypsum-perlite or gypsum-vermiculite on metal lath—

- (a) the lath must be fixed at not more than 600 mm centres vertically to steel furring channels, and—
 - (i) if the plaster is to be 35 mm thick or more — at least 12 mm clear of the column; or
 - (ii) if the plaster is to be less than 35 mm thick — at least 6 mm clear of the column; or

- (b) the plaster may be applied to self-furring lath with furring dimples to hold it not less than 10 mm clear of the column, and
the thickness of the plaster must be measured from the back of the lath.

7.3 Beams

For the fire protection of steel beams with gypsum-perlite or gypsum-vermiculite on metal lath—

- (a) the lath must be fixed at not more than 600 mm centres to steel furring channels and at least 20 mm clear of the steel; and
- (b) the thickness of the plaster must be measured from the back of the lath.

8. Exposure of columns and beams

8.1 Columns

A column incorporated in or in contact on one or more sides with a wall of solid masonry or concrete at least 100 mm thick may be considered to be exposed to fire on no more than 3 sides.

8.2 Beams

A beam, open-web joist, girder or truss in direct and continuous contact with a concrete slab or a hollow block floor or roof may be considered to be exposed to fire on no more than 3 sides.

9. Filling of column spaces

- (a) The spaces between the fire-protective material and the steel (and any re-entrant parts of the column itself) must be filled solid with a fire-protective material like concrete, gypsum or grout.
- (b) The insides of hollow sections, including pipes, need not be filled.

10. Hollow terracotta blocks

The proportion of cored holes or perforations in a hollow terracotta block (based on the overall rectangular volume of the unit) must not exceed the following:

- (a) For blocks up to 75 mm thick — 35%.
- (b) For blocks more than 75 mm but not more than 100 mm thick — 40%.
- (c) For blocks more than 100 mm — 50%.

11. Reinforcement for column and beam protection

11.1 Masonry

Masonry of calcium-silicate, fired clay and concrete for the protection of steel columns must have steel-wire or mesh reinforcement in every second course and lapped at the corners.

11.2 Gypsum blocks and hollow terracotta blocks

Gypsum blocks and hollow terracotta blocks for the protection of steel columns must have steel-wire or mesh reinforcement in every course and lapped at corners.

11.3 Structural concrete and poured gypsum

If a steel column or a steel beam is to be protected with structural concrete or poured gypsum, the concrete or gypsum must be reinforced with steel-wire mesh or steel-wire binding placed about 20 mm from its outer surface, and—

- (a) for concrete or gypsum less than 50 mm thick, the steel wire must be—
 - (i) not less than 3.15 mm in diameter; and
 - (ii) spaced at not more than 100 mm vertically; or
- (b) for concrete or gypsum not less than 50 mm thick, the steel wire must be either—
 - (i) of a diameter and spacing in accordance with (a); or
 - (ii) not less than 5 mm in diameter and spaced at not more than 150 mm vertically.

Fire-resistance of Building Elements

11.4 Gypsum-perlite or gypsum-vermiculite plaster sprayed to contour

- (a) If a steel column or steel beam is protected with either gypsum-perlite or gypsum-vermiculite plaster sprayed to contour and the construction falls within the limits of [Table 11.4](#), the plaster must be reinforced with—
 - (i) expanded metal lath complying with [Clause 1.6 of this Annexure](#); or
 - (ii) galvanised steel wire mesh complying with [Clause 1.6 of this Annexure](#).
- (b) The reinforcement must be placed at a distance from the face of the plaster of at least 1/3 of the thickness of the plaster and must be securely fixed to the column or beam at intervals of not more than the relevant listing in [Table 11.4](#).
- (c) For the purposes of [Table 11.4](#)—
 - (i) “vertical” includes a surface at not more than 10° to the vertical; and
 - (ii) “horizontal” includes a surface at not more than 10° to the horizontal; and
 - (iii) “underside” means the underside of any horizontal or non-vertical surface.

Table 11.4 Reinforcement of gypsum-perlite or gypsum-vermiculite plaster sprayed to contour

Surface to be protected	Reinforcement required if smaller dimension of surface exceeds (mm)	Max spacing of fixings of the mesh to surface (mm)
Vertical members with H or I cross-section	450	450
Non-vertical members with H or I cross-section	300	300
Underside members with H or I cross section	300	300
Upper sides of horizontal surface members with H or I cross-section	Not required	N/A
Vertical members with other shapes	Any size	450
Non-vertical members with other shapes	Any size	300
Underside members with other shapes	Any size	300
Upper side of horizontal surface members with other shapes	Not required	N/A

12. Thickness of column and beam protection

12.1 Measurement of thickness

The thickness of the fire protection to steel columns and steel beams (other than fire protection of gypsum-perlite or gypsum-vermiculite plaster sprayed on metal lath or sprayed to contour) is to be measured from the face or edge of the steel, from the face of a splice plate or from the outer part of a rivet or bolt, whichever is the closest to the outside of the fire-protective construction, except that—

- (a) if the thickness of the fire protection is 40 mm or more, rivet heads may be disregarded; and
- (b) if the thickness of the fire protection is 50 mm or more—
 - (i) any part of a bolt (other than a high-tensile bolt) may be disregarded; and
 - (ii) a column splice plate within 900 mm of the floor may encroach upon the fire protection by up to a 1/4 of the thickness of the fire protection; and
- (c) the flange of a column or beam may encroach by up to 12 mm upon the thickness of the fire protection at right angles to the web if—
 - (i) the column or beam is intended to have an FRL of 240/240/240 or 240/—/—; and
 - (ii) the flange projects 65 mm or more from the web; and
 - (iii) the thickness of the edge of the flange (inclusive of any splice plate) is not more than 40 mm.

Fire Hazard Properties

Schedule 6 Fire hazard properties

Schedule 6 Fire Hazard Properties

Schedule 6 Fire hazard properties

1. Scope
2. Assemblies
 - 2.1 General requirement
 - 2.2 Form of test
 - 2.3 Test specimens
 - 2.4 Concession
 - 2.5 Smaller specimen permitted

Schedule 6 Fire hazard properties

1. Scope

This Schedule sets out the procedures for determining the *fire hazard properties* of assemblies tested to AS/NZS 1530.3.

2. Assemblies

2.1 General requirement

The *fire hazard properties* of assemblies and their ability to screen their core materials as *required* under [Specification C1.10](#) must be determined by testing in accordance with this Clause.

2.2 Form of test

Tests must be carried out in accordance with—

- (a) for the determination of the *Spread-of-Flame Index* and *Smoke-Developed Index* — AS/NZS 1530.3; and
- (b) for the determination of the ability to prevent ignition and to screen its core material from free air — AS 1530.4.

2.3 Test specimens

Test specimens must incorporate—

- (a) all types of joints; and
- (b) all types of perforations, recesses or the like for pipes, light switches or other fittings, which are proposed to be used for the member or assembly of members in the building.

2.4 Concession

[Clause 2.3](#) does not apply to joints, perforations, recesses or the like that are larger than those in the proposed application and have already been tested in the particular form of construction concerned and found to comply with the conditions of the test.

2.5 Smaller specimen permitted

A testing laboratory may carry out the test specified in [Clause 2.2\(b\)](#) at pilot scale if a specimen (which must be not less than 900 mm x 900 mm) will adequately represent the proposed construction in the building, but the results of that test do not apply to construction larger than limits defined by the laboratory conducting the pilot examination.

Fire Safety Verification Method

- 1.0 Preface
- 1.1 Purpose
- 1.2 How to use this Verification Method
- 1.3 Performance-based design
- 1.4 Design scenarios: NCC Performance Requirements
- 1.5 Fire modelling to determine ASET
- 2.1 Design scenario (BE)
- 2.2 Design scenario (UT)
- 2.3 Design scenario (CS)
- 2.4 Design scenario (SF)
- 2.5 Design scenario (HS)
- 2.6 Design scenario (VS)
- 2.7 Design scenario (IS)
- 2.8 Design scenario (FI)
- 2.9 Design scenario (UF)
- 2.10 Design scenario (CF)

2.11 Design scenario (RC)

2.12 Design Scenario (SS)

Schedule 7 Fire Safety Verification Method

- 1.0 Preface
- 1.1 Purpose
- 1.2 How to use this Verification Method
- 1.3 Performance-based design
 - 1.3.1 Performance-based design brief (PBDB)
 - 1.3.2 Final report
- 1.4 Design scenarios: NCC Performance Requirements
- 1.5 Fire modelling to determine ASET
- 2.1 Design scenario (BE)
 - 2.1.1 Design scenario description
 - 2.1.2 Typical method or solution
- 2.2 Design scenario (UT)
 - 2.2.1 Design scenario description
 - 2.2.2 Typical method or solution
- 2.3 Design scenario (CS)
 - 2.3.1 Design scenario description
 - 2.3.2 Typical method or solution
- 2.4 Design scenario (SF)
 - 2.4.1 Design scenario description
 - 2.4.2 Typical method or solution
- 2.5 Design scenario (HS)
 - 2.5.1 Design scenario description
 - 2.5.2 Typical method or solution
- 2.6 Design scenario (VS)
 - 2.6.1 Design scenario description
 - 2.6.2 Method
- 2.7 Design scenario (IS)
 - 2.7.1 Design scenario description
 - 2.7.2 Typical method or solution
- 2.8 Design scenario (FI)
 - 2.8.1 Design scenario description
 - 2.8.2 Typical method or solution
- 2.9 Design scenario (UF)
 - 2.9.1 Design scenario description
 - 2.9.2 Typical method or solution
- 2.10 Design scenario (CF)
 - 2.10.1 Design scenario description

2.10.2 Typical method or solution

2.11 Design scenario (RC)

2.11.1 Design scenario description

2.11.2 Typical method or solution

2.12 Design Scenario (SS)

2.12.1 Design scenario description

2.12.2 Typical method or solution

1.0 Preface

Note:

[Schedule 7](#) does not take effect until 1 May 2020.

This Fire Safety Verification Method provides a process for engineering the design of fire safety *Performance Solutions*. The document provides the flexibility required to develop *Performance Solutions* while still maintaining the level of safety required by the NCC.

To ensure that the level of safety *required* by the NCC is maintained, the level of safety achieved using this *Verification Method* must be at least equivalent to the relevant NCC Volume One *Deemed-to-Satisfy Provisions*.

Section 1 of this document provides an introduction to the *Verification Method* and its application.

Section 2 describes the *design fire* scenarios.

1.1 Purpose

This *Verification Method* presents specific *design scenarios* that must be considered in order to demonstrate that the fire safety aspects of a building design comply with the fire safety *Performance Requirements* of NCC Volume One set out in [Table 1.1](#). The level of safety achieved by the building design must be at least equivalent to the relevant *Deemed-to-Satisfy Provisions*.

For the purposes of developing a *Performance Solution*, this *Verification Method* must only be used by fire safety engineers who are suitably qualified and experienced, and—

- have demonstrated competency in *fire safety engineering*; and
- are proficient in the use of fire engineering modelling methods; and
- are familiar with fire testing and validation of computational data.

This *Verification Method* is not a comprehensive guide to fire safety. The International Fire Engineering Guidelines (2005), provides more comprehensive guidelines on fire safety calculation procedures. The ABCB Fire Safety Verification Method Handbook provides specific guidance on the following as relevant to this *Verification Method*:

- Occupant characteristics.
- Rules and parameters of *design scenarios*.
- Guidelines on modelling.
- Documentation.

Explanatory information:

This *Verification Method* is one way, but not the only way, to demonstrate compliance with the *Performance Requirements* set out in [Table 1.1](#). *Performance Solutions* developed from first principles, or meeting the relevant *Deemed-to-Satisfy Provisions*, remain acceptable ways to demonstrate compliance.

Also, other *Performance Requirements* not covered by this *Verification Method* may need to be considered in order to comply with [A2.2\(3\)](#) and [A2.4\(3\)](#) as applicable.

1.2 How to use this Verification Method

This *Verification Method* sets out twelve *design scenarios* that must be considered in order to demonstrate that a building incorporating one or more *Performance Solutions* satisfies the *Performance Requirements* set out in [Table 1.1](#).

Each *design scenario* must consider one or more locations in the building that capture the range of reasonable possibilities in relation to the threat to safety. The level of safety that the building design achieves must be at least equivalent to the relevant *Deemed-to-Satisfy Provisions*.

All *design scenarios* applicable to a *Performance Requirement* must be assessed to demonstrate compliance with that *Performance Requirement*.

Explanatory information:

In many cases the location that is the most challenging for a particular *design scenario* will be easily determined. Where it is not easily determined, the particular *design scenario* should be run in multiple locations to ensure the most challenging location is modelled.

1.3 Performance-based design

1.3.1 Performance-based design brief (PBDB)

When using this *Verification Method*, the fire safety engineer must undertake a *performance-based design brief (PBDB)* that must involve all stakeholders relevant to the building design. The *PBDB* must also outline the fire strategy to be adopted.

While full agreement on all aspects of the *PBDB* is the preferred outcome, it is acknowledged that in some instances this may not be possible to obtain. In the event that full agreement cannot be achieved through the *PBDB*, dissenting views must be appropriately recorded and carried throughout the process and considered as part of the due processes of the *appropriate authority* when determining compliance and providing approval.

Consideration of whether a peer review (by an independent fire safety engineer) of some or all of the proposed *Performance Solutions* and the supporting analysis is required or not, must be undertaken at this *PBDB* stage.

Explanatory information:

When developing a *Performance Solution*, a *PBDB* is an important step in the process. It allows all relevant stakeholders to be involved in the development of the building design and its *fire safety system*.

A *PBDB* is a documented process that defines the scope of work for the fire engineering analysis. Its purpose is to set down the basis, as agreed by the relevant stakeholders, on which the fire safety analysis of the proposed building and its *Performance Solutions* will be undertaken.

Relevant stakeholders will vary from design to design. However, some examples of relevant stakeholders are: a fire safety engineer, architect, developer, client, *appropriate authority* (some state legislation prevents *appropriate authorities* from being involved in the design process), fire authority and other stakeholders that fire safety design may affect such as insurers. Further information on the relevant stakeholders is provided in Clause 1.3.1.2.

Guidance on the development of a *PBDB* is presented in the International Fire Engineering Guidelines (2005) and referred to as a Fire Engineering Brief in that document.

1.3.1.1 Fire strategy

The *PBDB* must cover the fire safety strategy for the building, outlining the philosophy and approach that will be adopted to achieve the required level of performance. The fire safety strategy must pay particular attention to the evacuation strategy to be used and the management regimes necessary.

1.3.1.2 Stakeholder involvement

The *PBDB* must be developed collaboratively by the relevant stakeholders in the particular project. The following parties must be involved:

- Client or client's representative (such as project manager)
- Fire engineer
- Architect or designer
- Various specialist consultants
- Fire service (public or private)
- *Appropriate authority* (Authority Having Jurisdiction – subject to state legislation)
- Tenants or tenants representative for the proposed building (if available)
- Building operations management (if available).

Conducting a simple stakeholder analysis can be used to determine who must be involved in the *PBDB* process. This analysis must identify stakeholders with a high level of interest in the design process, and/or likely to be affected by the consequences of a fire should it occur in the building.

1.3.1.3 Required level of safety

Given the absence of specific safety targets in the NCC and the qualitative nature of the NCC fire safety *Performance Requirements*, for this *Verification Method* to ensure the level of safety expected, the proposed building design must be at least equivalent to the relevant *Deemed-to-Satisfy Provisions*.

As the NCC *Deemed-to-Satisfy Provisions* evolved originally from State and Territory regulations and are regularly

Fire Safety Verification Method

updated to reflect technical advances and experience they are commonly accepted as providing an acceptable benchmark. It is accepted that the NCC *Deemed-to-Satisfy Provisions* reflect societal expectations in terms of fire safety, which address individual risk, societal risk and the robustness in the design by adopting a defence in depth approach.

In the majority of *design scenarios* the *Verification Method* requires a demonstration that the proposed level of safety is at least equivalent to the *Deemed-to-Satisfy Provisions*. In relation to the required level of safety the *PBDB* process must—

- (a) identify the relevant *Deemed-to-Satisfy Provisions* to be used in the equivalency process to determine whether the relevant *Performance Requirements* have been met; and
- (b) consider the specific size, complexity and use of the building with regards to the *Deemed-to-Satisfy Provisions* to be used in the equivalency process; and
- (c) consider the specific occupant profile of the building, paying particular attention to occupants with a disability and the vulnerable, in regards to the *Deemed-to-Satisfy Provisions* to be used in the equivalency process.

1.3.2 Final report

Once the analysis of all relevant *design scenarios* for all the required *Performance Solutions* has been completed, the fire safety engineer must prepare a final report that includes the following:

- The agreed *PBDB*.
- All modelling and analysis.
- Analysis required to demonstrate that the proposed building provides a level of safety at least equivalent to the relevant *Deemed-to-Satisfy Provisions*.
- Any other information required to clearly demonstrate that the building and its *fire safety system* satisfies the relevant *Performance Requirements* as set out in *Table 1.1*.

1.4 Design scenarios: NCC Performance Requirements

This *Verification Method* presents specific *design scenarios* that must be considered in order to demonstrate that the fire safety aspects of a building design comply with the fire safety *Performance Requirements* set out in [Table 1.1](#).

The *design scenarios* specified in Section 2 are summarised in [Table 1.1](#).

Table 1.1 Key features of design scenarios

<i>Design scenario</i>	<i>Performance Requirement</i> Note 1	<i>Outcome required</i> Note 3	<i>Typical method or solution</i>
BE Fire blocks <i>evacuation route</i> (2.1). [A fire blocks an <i>evacuation route</i>]	CP1, CP2, CP3, CP8, DP4, DP5, DP6, DP7 ^{Note 2} , EP1.4, EP2.1, EP2.2, EP4.1, EP4.2, EP4.3	Demonstrate that the level of safety is at least equivalent to the <i>Deemed-to-Satisfy Provisions</i> .	Demonstrate that a viable <i>evacuation route</i> (or multiple <i>evacuation routes</i> where necessary) has been provided for building occupants.
UT Fire in a normally unoccupied room threatens occupants of other rooms (2.2). [A fire starts in a normally unoccupied room and can potentially endanger a large number of occupants in another room]	CP1, CP2, CP3, CP8, DP4, DP5, EP1.4, EP2.1, EP2.2, EP4.1, EP4.2, EP4.3	Demonstrate that the level of safety is at least equivalent to the <i>Deemed-to-Satisfy Provisions</i> .	<i>ASET / RSET</i> analysis or provide separating construction or fire suppression complying with a specified Standard. Solutions might include the use of <i>separating elements</i> or fire suppression to confine the fire to the room of origin.
CS Fire starts in concealed space (2.3). [A fire starts in a concealed space that can facilitate fire spread and potentially endanger a large number of people in a room]	CP1, CP2, CP3, CP6, CP8, DP4, DP5, DP6, EP1.4, EP2.1, EP2.2, EP4.1, EP4.2, EP4.3	Demonstrate that fire spread via concealed spaces will not endanger occupants; and Demonstrate that the level of safety is at least equivalent to the <i>Deemed-to-Satisfy Provisions</i> .	Solutions might include providing separating construction or fire suppression or <i>automatic</i> detection complying with a specified Standard.
SF Smouldering fire (2.4). [A fire is smouldering in close proximity to a sleeping area]	CP2, CP3, CP8, DP4, DP5, DP6, EP1.1, EP1.2, EP1.3, EP1.4, EP2.1, EP2.2, EP4.1, EP4.2, EP4.3	Demonstrate that the level of safety is at least equivalent to the <i>Deemed-to-Satisfy Provisions</i> .	Solutions might include providing <i>automatic</i> detection and alarm system complying with a recognised Standard.
HS Horizontal fire spread (2.5). [A <i>fully developed fire</i> in a building exposes the <i>external walls</i> of a neighbouring building]	CP2	Demonstrate that the risk of fire spread between buildings is not greater than buildings complying with the <i>Deemed-to-Satisfy Provisions</i> .	CV1, CV2.
VS Vertical fire spread involving cladding or arrangement of openings in walls (2.6). [A fire source exposes a wall and leads to significant vertical fire spread]	CP2, CP4, CP7, CP8, EP2.2	Demonstrate that the building's external cladding / facade and arrangement of openings in the building do not increase the risk to life resulting from a fire beyond that for a similar building complying with the <i>Deemed-to-Satisfy Provisions</i> .	CV3.
IS Fire spread involving	CP2, CP4, DP4, DP5, DP6, EP1.1, EP1.4, EP2.1,	Maintain tenable conditions to allow time for evacuation	<i>ASET / RSET</i> analysis or equivalent growth and

Fire Safety Verification Method

Design scenario	Performance Requirement Note 1	Outcome required Note 3	Typical method or solution
internal finishes (2.7). [Interior surfaces are exposed to a growing fire that potentially endangers occupants].	EP2.2, EP4.1, EP4.2, EP4.3	of occupants and to facilitate <i>fire brigade</i> intervention; and Demonstrate that the level of safety is at least equivalent to the <i>Deemed-to-Satisfy Provisions</i> .	species production rates.
FI <i>Fire brigade</i> intervention (2.8). [Consider <i>fire brigade</i> intervention]	CP1, CP2, CP5, CP7, CP9, DP5, EP1.3, EP1.6, EP2.2, EP3.2	Demonstrate consideration of potential <i>fire brigade</i> intervention; and Demonstrate that the level of safety is at least equivalent to the <i>Deemed-to-Satisfy Provisions</i> .	Facilitate <i>fire brigade</i> intervention to the degree necessary.
UF Unexpected Catastrophic Failure (2.9). [A building must not unexpectedly collapse during a fire event]	CP1, CP2, CP9	Demonstrate that the building, its critical elements and the <i>fire safety system</i> provide sufficient robustness such that unexpected catastrophic failure is unlikely; and Demonstrate that the level of safety is at least equivalent to the <i>Deemed-to-Satisfy Provisions</i> .	Undertake review or risk assessment of critical elements within a building to determine unexpected catastrophic failure is unlikely.
CF Challenging fire (2.10). [Worst credible fire]	CP1, CP2, CP3, CP8, DP4, DP5, DP6, EP1.1, EP1.2, EP1.3, EP1.4, EP2.1, EP2.2, EP4.1, EP4.2, EP4.3	Demonstrate that the level of safety is at least equivalent to the <i>Deemed-to-Satisfy Provisions</i> .	<i>ASET / RSET</i> analysis.
RC Robustness check (2.11). [Failure of a critical part of the <i>fire safety systems</i> will not result in the design not meeting the Objectives of the BCA]	CP1, CP2, CP3, CP8, DP4, DP5, DP7 ^{Note 2} , EP1.1, EP1.2, EP1.3, EP1.4, EP2.1, EP2.2, EP4.1, EP4.2, EP4.3	Demonstrate that if a key component of the <i>fire safety system</i> fails, the design is sufficiently robust that a disproportionate spread of fire does not occur (e.g. <i>ASET / RSET</i> for the remaining floors or <i>fire compartments</i> is satisfied); and Demonstrate that the level of safety is at least equivalent to the <i>Deemed-to-Satisfy Provisions</i> .	Modified <i>ASET / RSET</i> analysis.
SS Structural Stability and other properties (2.12). [Building does not present risk to other properties in a fire event]	CP1, CP5	Demonstrate that the building does not present an unacceptable risk to other property due to collapse or barrier failure resulting from a fire; and Demonstrate that the level of safety is at least equivalent to the <i>Deemed-to-Satisfy Provisions</i> .	Undertake analysis of structure and <i>fire safety systems</i> .

Notes to Table 1.1:

- Not all of these requirements will always be applicable to this *design scenario*. The project specific *Performance Requirements* must be determined as part of the *performance-based design brief* process.

Fire Safety Verification Method

2. Appropriate analysis of DP7 is also required where a lift is intended to be used to assist occupants to evacuate.
3. When *required* to demonstrate that the level of safety is at least equivalent to the *Deemed-to-Satisfy Provisions* refer to [Clause 1.3.1.3](#).

Table 1.2 List of Performance Requirements and relevant design scenario

<i>Performance Requirement</i>	<i>Design scenario</i>
CP1	BE, UT, CS, FI, UF, CF, RC, SS
CP2	BE, UT, CS, SF, HS, IS, FI, CF, RC, UF, VS
CP3	BE, UT, CS, SF, CF, RC
CP4	IS, VS
CP5	FI, SS
CP6	CS
CP7	FI, VS
CP8	BE, UT, CS, SF, CF, RC, VS
CP9	FI, UF
DP4	BE, UT, CS, SF, IS, CF, RC
DP5	BE, UT, CS, SF, IS, FI, CF, RC
DP6	BE, CS, SF, IS, CF, RC
DP7	BE, RC
EP1.1	SF, IS, CF, RC
EP1.2	SF, CF, RC
EP1.3	SF, FI, CF, RC
EP1.4	BE, UT, CS, SF, IS, CF, RC
EP1.6	FI
EP2.1	BE, UT, CS, SF, IS, CF, RC
EP2.2	BE, UT, CS, SF, IS, FI, CF, RC, VS
EP3.2	FI
EP4.1	BE, UT, CS, SF, IS, CF, RC
EP4.2	BE, UT, CS, SF, IS, CF, RC
EP4.3	BE, UT, CS, SF, IS, CF, RC

1.5 Fire modelling to determine ASET

For particular *design scenarios*, the designer must demonstrate that the occupants have sufficient time to evacuate the building before being overcome by the effects of fire.

In *fire safety engineering* terms, the *ASET* must be greater than the *RSET*.

ASET is defined as the time between ignition of the *design fire* and the time when the first tenability criterion is exceeded in a specified room within the building. The tenability parameters measured at a height of 2 m above floor level, are—

- (a) a *FED* of thermal effects greater than 0.3; or
- (b) conditions where, due to smoke obscuration, *visibility* is less than 10 m except in rooms of less than 100 m² or where the distance to an *exit* is 5 m or less, where *visibility* may fall to 5 m.

Explanatory information:

Visibility is generally the first tenability criterion exceeded in calculations unless any exception is applied.

Calculate the *ASET* by modelling the fire using the *design fire* as specified. In most cases there will be a number of locations for the fire that could produce the lowest *ASET* for a given escape route. Check a number of rooms to determine the limiting case.

It must be demonstrated that the proposed level of safety is at least equivalent to that provided by a building compliant with the *Deemed-to-Satisfy Provisions*.

2.1 Design scenario (BE)

Fire blocks evacuation route

Design scenario in brief

A fire starts in an *evacuation route* and can potentially block the *evacuation route*.

Required outcome

Demonstrate that the level of safety is at least equivalent to the *Deemed-to-Satisfy Provisions*.

2.1.1 Design scenario description

This *design scenario* addresses the concern that an *evacuation route* may be blocked due to proximity of the fire source. For each room/space within the building, assume that the fire source is located near the primary *evacuation route* and that it prevents occupants from leaving the building by that route. Fire in *evacuation routes* can be the result of an accidental or deliberately lit fire.

In order to be regarded as alternative *evacuation routes*, the *evacuation routes* must be separated from each other and must remain separated until reaching a final *exit* in accordance with D1.5, or as demonstrated equivalent through analysis.

Active and passive *fire safety systems* in the building must be assumed to perform as intended by the design.

Explanatory information:

The fire safety engineer needs to consider fire source locations that prevent the use of *exits* in *evacuation routes*.

Fire characteristics (e.g. HRR) and analysis need not be considered in this *design scenario* as the fire is assumed to physically block the *evacuation route*. It may be assumed that occupant tenability criteria cannot be met where fire plumes and flames block an *evacuation route*.

2.1.2 Typical method or solution

The requirements of this *design scenario* can be demonstrated by analysis that checks whether or not a second *evacuation route* is required.

2.2 Design scenario (UT)

Fire in normally unoccupied room threatening occupants of other rooms

Design scenario in brief

A fire starts in a normally unoccupied room and can potentially endanger a large number of occupants in another room.

Required outcome

Demonstrate that the level of safety is at least equivalent to the *Deemed-to-Satisfy Provisions*.

2.2.1 Design scenario description

This *design scenario* only applies to buildings with rooms or spaces that could be threatened by a fire occurring in another normally unoccupied space. Such rooms or spaces must include those rooms or spaces physically adjacent to the unoccupied room as well as rooms or spaces that are a farther distance and are not fire separated; or rooms or spaces from which occupants or slower evacuees have to pass through a potentially threatened room or space adjacent to the unoccupied room. It does not need to be satisfied for any other rooms or spaces in the building.

A fire starting in an unoccupied space can grow to a significant size undetected and then spread to other areas where people may be present or where people are young, elderly or have a disability and will take longer to evacuate. This *design scenario* is intended to address concern regarding fire starting in a normally unoccupied room and then migrating into space(s) potentially holding occupants.

The analysis must assume that the target space containing occupants is filled to capacity under normal use or otherwise contains occupants with longer evacuation times.

For analysis, select a *design fire* for the applicable occupancy. Active and passive *fire safety systems* in the building must be assumed to perform as intended by the design.

2.2.2 Typical method or solution

Either—

- (a) carry out *ASET* / *RSET* analysis to show that the occupants within target spaces are not exposed to untenable conditions, or
- (b) include *separating elements* or fire suppression to confine the fire to the room of origin.

2.3 Design scenario (CS)

Fire starts in a concealed space

Design scenario in brief

A fire starts in a concealed space that can potentially endanger people in another room or in the room of fire origin.

Required outcome

Demonstrate that fire spread via concealed spaces will not endanger occupants located in other rooms / spaces; and
Demonstrate that the proposed level of safety is at least equivalent to the *Deemed-to-Satisfy Provisions*.

2.3.1 Design scenario description

This *design scenario* only applies to buildings with rooms or spaces that could be threatened by a fire occurring in a concealed space. Such rooms or spaces must include those rooms or spaces physically adjacent to the concealed space as well as rooms or spaces that are a farther distance and are not fire separated; or rooms or spaces where slower evacuees have to pass through a potentially threatened room or space adjacent to the concealed space. It does not need to be satisfied for any other rooms or spaces in the building.

A fire starting in a concealed space can develop undetected and spread to endanger a large number of occupants in another room. This *design scenario* addresses concern that a fire originating in a non-separated concealed space without either a detection system or suppression system could spread into a room within the building potentially holding a large number of occupants.

Assume that active and passive *fire safety systems* in the building perform as intended by the design.

Explanatory information:

Fire spreading in concealed spaces may also compromise the ability of firefighters to assess the threat to themselves whilst undertaking rescue and firefighting operations.

2.3.2 Typical method or solution

If a calculation approach using this *Verification Method* is used, the expected solution will most likely be to—

- (a) use *separating elements* or suppression to confine fire to the concealed space, or
- (b) include *automatic* detection of heat or smoke to provide early warning of fire within the concealed space, or
- (c) a combination of (a) and (b).

2.4 Design scenario (SF)

Smouldering fire

Design scenario in brief

A fire is smouldering in close proximity to a sleeping area.

Required outcome

Provide a safe sleeping area.

Demonstrate that the level of safety be at least equivalent to the *Deemed-to-Satisfy Provisions*.

2.4.1 Design scenario description

This *design scenario* addresses the concern regarding a slow, smouldering fire that causes a threat to sleeping occupants. Assume that active and passive *fire safety systems* in the building perform as intended by the design.

2.4.2 Typical method or solution

The expected methodology is to either—

- (a) use *separating elements* to confine the fire to the space of origin (assuming it is a separate space from the sleeping area), or
- (b) include *automatic* detection of smoke in adjacent spaces to provide early warning of fire within an adjoining space.

The *separating elements* must prevent all smoke ingress which, for almost all situations requires a pressure differential between the two spaces in addition to a physical barrier. The pressure differential will have to be sufficient to prevent smoke ingress to the sleeping area.

If the *automatic* detection methodology is chosen, then an *automatic* smoke detection and alarm system must be installed throughout the sleeping and adjoining spaces.

2.5 Design scenario (HS)

Horizontal fire spread

Design scenario in brief

A *fully developed fire* in a building exposes the *external walls* of a neighbouring building or *fire compartment* and a *fully developed fire* in the neighbouring building exposing the opening in the *external walls* of the building.

Required outcome

Demonstrate that the risk of fire spread between buildings is not greater than buildings complying with the *Deemed-to-Satisfy Provisions*.

2.5.1 Design scenario description

This *design scenario* describes the requirements for a building to prevent horizontal fire spread to and from an adjacent building or *fire compartment*.

2.5.2 Typical method or solution

Demonstrate compliance with *CV1* and *CV2*.

2.6 Design scenario (VS)

Vertical fire spread involving external cladding or external openings

Design scenario in brief

A fire source exposes the *external wall* or arrangement of openings in a building and leads to significant vertical fire spread.

Required outcome

Demonstrate that the building's external cladding / facade and arrangement of openings in the building do not increase the risk to life resulting from a fire beyond that for a similar building complying with the *Deemed-to-Satisfy Provisions*.

2.6.1 Design scenario description

This *design scenario* applies to all buildings where there is a risk of vertical fire spread.

Comment:

This *design scenario* is not concerned with building-to-building fire spread across a relevant boundary, as this is addressed in the *design scenario*: HS (see 2.5).

2.6.2 Method

Demonstrate compliance with CV3.

2.7 Design scenario (IS)

Rapid fire spread involving internal surface linings

Design scenario in brief

Interior surfaces are exposed to a growing fire that potentially endangers building occupants.

Required outcome

Demonstrate that the level of safety be at least equivalent to the [Deemed-to-Satisfy Provisions](#).

2.7.1 Design scenario description

The performance criteria required for lining materials will depend on their location within a building, and the use of the building.

2.7.2 Typical method or solution

Linings, materials and assemblies in Class 2 to 9 buildings must comply with the appropriate provisions in NCC Volume One Specification C1.10 [Table 1](#) or be demonstrated to provide equivalent performance with respect to the performance criteria prescribed in the referenced test standards.

2.8 Design scenario (FI)

Fire brigade intervention

Design scenario in brief

This *design scenario* allows for *fire brigade* intervention.

Required outcome

Demonstrate that the *fire brigade* can undertake *fire brigade* intervention until completion of search and rescue activities; and

Demonstrate that the level of safety be at least equivalent to the *Deemed-to-Satisfy Provisions*.

2.8.1 Design scenario description

The purpose of this *design scenario* is to describe—

- (a) the fire event the *fire brigade* is expected to face at its estimated time of arrival; and
- (b) the scope of available fire-fighting facilities relative to the risk to building occupant safety and adjacent buildings; and
- (c) the ability for the *fire brigade* to complete search and rescue activities relevant to the available firefighting activities; and
- (d) the ability of the *fire brigade* to control or suppress a fire.

Explanatory information:

This *design scenario* is intended to be used in conjunction with the UF *design scenario* (See 2.9). These two *design scenarios* will demonstrate that facilities for *fire brigade* intervention are appropriately incorporated.

2.8.2 Typical method or solution

This *design scenario* only applies to buildings located within 50 km road travel of a fire station.

Compliance with this *design scenario* is demonstrated via application of the Australasian Fire and Emergency Service Authorities Council's (AFAC) Fire Brigade Intervention Model and modelling the fire and smoke development, in accordance with the CF *design scenario* (2.10).

Facilities for firefighting must be provided in accordance with Table 2.8, appropriate to the fire and smoke development at the estimated time of suppression activities.

Table 2.8 Facilities for fire brigade intervention

Facilities for fire brigade intervention	Building with sprinkler protection	Building without sprinkler protection
<i>Fire brigade</i> external access	Yes	Yes
Tenability to enable identification and access to seat of fire	Yes	Yes
Fire hydrants – internal required	Yes if > than 100 m to all points, and / or > 3 levels	Yes if > than 70 m to all points, and / or > 3 levels
Fire hydrants – external required	Yes	Yes
Command and control provisions	Yes if > 3 levels	Yes
Access to normally occupied areas for search and rescue	Yes if more than 50 persons occupy building	Yes

2.9 Design scenario (UF)

Unexpected catastrophic failure

Design scenario in brief

The design will be suitably robust to prevent catastrophic structural failure in a fire.

Required outcome

Demonstrate that disproportionate failure does not occur for the duration of the fire event; and
Demonstrate that the level of safety be at least equivalent to the *Deemed-to-Satisfy Provisions*.

2.9.1 Design scenario description

The fundamental principles of the UF *design scenario* are that the building structure and/or critical elements should not suffer unexpected disproportionate failure during a fire event. This *design scenario* for the prevention of unexpected catastrophic failure aligns with the principles of structural robustness.

The unexpected catastrophic failure *design scenario* is intended to prevent unexpected catastrophic failure of a building component as a result of a fire event.

This *design scenario* assessment must be undertaken in conjunction with the structural engineer, to ensure that unexpected catastrophic failure should not occur for all critical elements. Ductility of the structure must also be considered so that visual cues that act as a warning occur prior to collapse.

Comment:

This *design scenario* is intended to be used in conjunction with the fire brigade intervention (FI) *design scenario*. These two *design scenarios* will ensure that facilities for *fire brigade* intervention are appropriately incorporated.

2.9.2 Typical method or solution

Compliance with this *design scenario* is achieved by demonstrating that the building structure and components have considered the following elements during a fire event:

- (a) Assessment of the building structure and critical components such that upon the notional removal, in isolation, due to the fire event the probability of unexpected catastrophic failure of the entire element, or a significant proportion, is unlikely to occur.
- (b) Demonstrating that if a component of the building is relied upon to carry a significant portion of the total structure, a systematic risk assessment of the building is undertaken and critical high risk components are identified. High risk components are designed to cope with the identified hazard or protective measures chosen to minimise the risk during a fire event. The proportion of the structure that triggers this analysis will have a range that the designer will have to identify and justify.

2.10 Design scenario (CF)

Challenging fire

Design scenario in brief

A fire starts in a normally occupied space and presents a challenge to the building's *fire safety systems*, threatening the safety of occupants.

Required outcome

Demonstrate that the level of safety be at least equivalent to the *Deemed-to-Satisfy Provisions*.

2.10.1 Design scenario description

The challenging fires are intended to represent the credible worst case *design scenario* in normally occupied spaces that will challenge the fire protection features of the building.

This *design scenario* requires the use of *design fires* in various locations within the building.

The *design fires* must be characterised with a steady state fire, or a power law HRR, peak HRR and FLED. Design values for *yields* are specified for soot/smoke.

The *design fires* must be modified during an analysis (depending on the methodology used) to account for building ventilation and the effects of *automatic* fire suppression systems (if any) on the fire. The *design scenario* RC (2.11) will require the overall robustness of the design to be examined separately.

The designer must—

- (a) for each location of the challenging fire, use a single fire source to evaluate the building's protection measures; and
- (b) consider the impact on occupants who may be using escape routes external to the building as well as internal routes; and
- (c) assume that active and passive *fire safety systems* in the building will perform as intended by the design.

Explanatory information:

Both CF and SS *design scenarios* refer to credible worst case *design fires*. These may not necessarily be the same *design fire*, as they relate to different safety systems of the building.

2.10.2 Typical method or solution

This *design scenario* requires the *ASET / RSET* analysis of the impact on all building occupants with *design fires* located in various locations within the building, except for those rooms or spaces excluded in the *design scenario* described above.

The designer must calculate the fire environment in the *evacuation routes* over the period of time the occupants require to escape. Assess the fire environment based on the *FED* and *visibility* at the location of the occupants.

The designer must select a fire calculation model appropriate to the complexity and size of the building/space that allows the *FED* and *visibility* to be determined.

2.11 Design scenario (RC)

Robustness check

Design scenario in brief

The fire design will be checked to ensure that the failure of a critical part of the *fire safety system* will not result in the design not meeting the *Performance Requirements*.

Required outcome

Demonstrate that if a single *fire safety system* fails, the design is sufficiently robust that disproportionate spread of the fire does not occur (e.g. *ASET* / *RSET* for the remaining floors or *fire compartments* is satisfied); and
Demonstrate that the level of safety be at least equivalent to the *Deemed-to-Satisfy Provisions*.

2.11.1 Design scenario description

This *design scenario* applies where failure of a key *fire safety system* could expose occupants to untenable conditions. The key fire safety systems must be agreed as part of the *PBDB*.

Comment:

The key fire safety systems to be considered must be agreed as part of the *PBDB*.

This particular *design scenario* focuses on the *ASET* / *RSET* life safety calculations performed as part of the *design scenario* CF challenging fire (2.10).

The robustness of the design must be tested by considering the *design fire* with each key *fire safety system* rendered ineffective in turn.

Where the probability of failure of a single system failure is low and it is impractical to provide additional redundancies it may be acceptable to accept some exposure of occupants to untenable conditions. An appropriate deemed-to-satisfy building should be used to provide a benchmark.

Explanatory information:

Ideally, a comprehensive quantitative probabilistic risk assessment would be used to assess the safety of a design. However, the risk assessment tools and supporting data have not been included in this *Verification Method*. The framework currently permits a simple deterministic *ASET* / *RSET* approach with additional checks and balances.

As a general rule, when calculating *ASET* times, *fire safety systems* may be assumed to operate as designed, provided they are manufactured and installed in accordance with recognised national or international standards. However, in the situations designed above, additional *fire safety systems* provide the redundancy and robustness to fire safety designs.

2.11.2 Typical method or solution

In the circumstances described in the *design scenario*, assume the failure of each key *fire safety system* in turn as determined by the *PBDB*. If *ASET* cannot be shown to be greater than *RSET* for the building, apart from the room of fire origin, then the design must be altered until the requirements for *ASET* and *RSET* are achieved.

2.12 Design Scenario (SS)

Structural stability and other property

Design scenario in brief

The fire design is used to demonstrate that the structural response of a building in a credible worst case *design scenario* does not present an unacceptable risk to *other property*.

Required outcome

Demonstrate that the building does not present an unacceptable risk to *other property* due to collapse or barrier failure resulting from a fire; and

Demonstrate that the level of safety be at least equivalent to the *Deemed-to-Satisfy Provisions*.

2.12.1 Design scenario description

Comment:

A fundamental requirement of CP1 and CP2 is that a building should not present a risk to *other property* in a fire event. The purpose of this *design scenario* is to demonstrate that a building does not present a risk to *other property* during a fire event that has the potential to impact on the building's structure.

Unlike the CF *design scenario*, the worst credible case fire for this *design scenario* must be located within any space of the building rather than only within an occupied space. It is likely that several different fire design locations will be required to be tested to determine the location of the worst credible case fire.

The designer must—

- (a) for each location of the *design fire*, use a single fire source to evaluate the building's protection measures; and
- (b) consider the impact on occupants who may be using *evacuation routes* external to the building as well as internal routes.

Explanatory information:

Both CF and SS *design scenarios* refer to credible worst case *design fires*. These may not necessarily be the same *design fire*, as they relate to different safety systems of the building.

2.12.2 Typical method or solution

The impact of a fully developed fire in the worst-case location on the structural stability of a building must be assessed.

Simultaneous and individual failures of active fire suppression systems (if provided), delayed *fire brigade* intervention and premature failure of structural fire protection should be considered and probabilities assigned to the occurrence of each of the events and the outcomes predicted.

If a simplistic approach is adopted the outcomes and probabilities of each combination of outcomes should be predicted and compared with a deemed-to-satisfy benchmark building.

Explanatory information:

Typically the fire safety engineer, with the assistance of a structural engineer, would demonstrate that appropriate features have been incorporated into the building which either—

- (a) ensure the risk of collapse is equivalent or less than a similar deemed-to-satisfy structure; and
- (b) there is no increased risk from outward structural collapse compared to a similar deemed-to-satisfy structure; and
- (c) the risk to life for the subject building is no greater than that for a similar deemed-to-satisfy structure.

History of Amendments

History of adoption

History of Amendments

History of adoption

- 1.0 Adoption of BCA96
- 1.1 Amendment No. 1
- 1.2 Amendment No. 2
- 1.3 Amendment No. 3
- 1.4 Amendment No. 4
- 1.5 Amendment No. 5
- 1.6 Amendment No. 6
- 1.7 Amendment No. 7
- 1.8 Amendment No. 8
- 1.9 Amendment No. 9
- 1.10 Amendment No. 10
- 1.11 Amendment No. 11
- 1.12 Amendment No. 12
- 1.13 Amendment No. 13
- 2.0 Adoption of BCA 2004
- 3.0 Adoption of BCA 2005
- 4.0 Adoption of BCA 2006
- 5.0 Adoption of BCA 2007
- 6.0 Adoption of BCA 2008
- 7.0 Adoption of BCA 2009
- 8.0 Adoption of BCA 2010
- 9.0 Adoption of BCA 2011
- 10.0 Adoption of BCA 2012
- 11.0 Adoption of BCA 2013
- 12.0 Adoption of BCA 2014
- 13.0 Adoption of BCA 2015
- 14.0 Adoption of NCC Volume Two 2016
- 15.0 Adoption of NCC Volume Two 2019

History of adoption

1.0 Adoption of BCA96

The 1996 edition of the BCA was adopted by the Commonwealth, States and Territories as set out in [Table 1.0](#).

Table 1.0 History of adoption of BCA96

Administration	Adoption Date
Australian Government	1 July 1997
Australian Capital Territory	1 July 1997
New South Wales	1 July 1997
Northern Territory	7 January 1998
Queensland	1 July 1997
South Australia	1 January 1998
Tasmania	1 July 1997
Victoria	1 August 1997
Western Australia	1 July 1997

1.1 Amendment No. 1

(a) Amendment No. 1 of the 1996 edition of the BCA was adopted by the Commonwealth, States and Territories as set out in [Table 1.1](#).

Table 1.1 History of adoption of Amendment No. 1 of BCA96

Administration	Adoption Date
Australian Government	1 July 1997
Australian Capital Territory	1 July 1997
New South Wales	1 July 1997
Northern Territory	7 January 1998
Queensland	1 July 1997
South Australia	1 January 1998
Tasmania	1 July 1997
Victoria	1 August 1997
Western Australia	1 July 1997

- (b) The purpose of Amendment No. 1 is to—
- (i) include typographical changes including spelling, punctuation, cross references and layout; and
 - (ii) include reference to a [Certificate of Conformity](#) issued by the ABCB in A2.2; and
 - (iii) change the reference to the Standards Mark Certificate to refer to JAS–ANZ in A2.2; and
 - (iv) update references to Standards.

Note:

The revisions contained in Amendment No. 1 to the [Housing Provisions](#) have not been marked in the text.

1.2 Amendment No. 2

(a) Amendment No. 2 of the 1996 edition of the BCA was adopted by the Commonwealth, States and Territories as set out in [Table 1.2](#).

Table 1.2 History of adoption of Amendment No. 2 of BCA96

Administration	Adoption Date
Australian Government	1 January 1998

History of Amendments

Administration	Adoption Date
Australian Capital Territory	1 January 1998
New South Wales	27 February 1998
Northern Territory	7 January 1998
Queensland	1 January 1998
South Australia	1 January 1998
Tasmania	1 January 1998
Victoria	1 January 1998
Western Australia	1 January 1998

- (b) The purpose of Amendment No. 2 is to—
- (i) include typographical changes including spelling, punctuation, cross references and layout; and
 - (ii) update references to Standards; and
 - (iii) include minor technical changes.

1.3 Amendment No. 3

- (a) Amendment No. 3 of the 1996 edition of the BCA was adopted by the Commonwealth, States and Territories as set out in [Table 1.3](#).

Table 1.3 History of adoption of Amendment No. 3 of BCA96

Administration	Adoption Date
Australian Government	1 July 1998
Australian Capital Territory	1 July 1998
New South Wales	1 July 1998
Northern Territory	1 July 1998
Queensland	1 July 1998
South Australia	13 July 1998
Tasmania	1 July 1998
Victoria	1 July 1998
Western Australia	1 July 1998

- (b) The purpose of Amendment No. 3 is to—
- (i) incorporate the outcomes of the 1997 ABCB Variations Conference; and
 - (ii) update references to Standards; and
 - (iii) include minor technical changes.

1.4 Amendment No. 4

- (a) Amendment No. 4 of the 1996 edition of the BCA was adopted as set out in [Table 1.4](#).

Table 1.4 History of adoption of Amendment No. 4 of BCA96

Administration	Adoption Date
Australian Government	1 January 1999
Australian Capital Territory	17 May 1999
New South Wales	1 February 1999
Northern Territory	1 January 1999
Queensland	1 January 1999
South Australia	1 January 1999
Tasmania	1 January 1999
Victoria	1 January 1999
Western Australia	1 January 1999

History of Amendments

- (b) The purpose of Amendment No. 4 is to—
- (i) update references to Standards; and
 - (ii) include minor technical changes.

1.5 Amendment No. 5

- (a) Amendment No. 5 of the 1996 edition of the BCA was adopted by the Commonwealth, States and Territories as set out in [Table 1.5](#).

Table 1.5 History of adoption of Amendment No. 5 of BCA96

Administration	Adoption Date
Australian Government	1 July 1999
Australian Capital Territory	3 November 1999
New South Wales	1 August 1999
Northern Territory	1 July 1999
Queensland	1 July 1999
South Australia	1 July 1999
Tasmania	1 July 1999
Victoria	1 July 1999
Western Australia	1 July 1999

- (b) The purpose of Amendment No. 5 is to—
- (i) update references to Standards; and
 - (ii) expand on the requirements for subfloor ventilation based on climatic conditions; and
 - (iii) revise the Acceptable Construction Practice for Steel framing; and
 - (iv) include additional details in the Acceptable Construction Practice for fencing of swimming pools; and
 - (v) include minor technical changes.

1.6 Amendment No. 6

- (a) Amendment No. 6 of the 1996 edition of the BCA was adopted by the Commonwealth, States and Territories as set out in [Table 1.6](#).

Table 1.6 History of adoption of Amendment No. 6 of BCA96

Administration	Adoption Date
Australian Government	1 January 2000
Australian Capital Territory	10 February 2000
New South Wales	1 January 2000
Northern Territory	1 January 2000
Queensland	1 January 2000
South Australia	17 January 2000
Tasmania	1 January 2000
Victoria	1 January 2000
Western Australia	1 January 2000

- (b) The purpose of Amendment No. 6 is to—
- (i) update references to Standards; and
 - (ii) revise the Acceptable Construction Practice for Footing and Slab Construction; and
 - (iii) replace Sound Transmission Class (STC) with weighted sound reduction index (R_w) within Part 3.8.6; and
 - (iv) include minor technical changes.

History of Amendments

1.7 Amendment No. 7

- (a) Amendment No. 7 of the 1996 edition of the BCA was adopted by the Commonwealth, States and Territories as set out in [Table 1.7](#).

Table 1.7 History of adoption of Amendment No. 7 of BCA96

Administration	Adoption Date
Australian Government	1 July 2000
Australian Capital Territory	10 July 2000
New South Wales	1 July 2000
Northern Territory	1 July 2000
Queensland	1 July 2000
South Australia	1 July 2000
Tasmania	1 July 2000
Victoria	1 July 2000
Western Australia	1 July 2000

- (b) The purpose of Amendment No. 7 is to—
- (i) update references to Standards; and
 - (ii) include requirements for separation of eaves and verandah spaces that are open to the roof space and common to 2 or more Class 1 buildings; and
 - (iii) reinstate the Acceptable Construction Practice for buildings in bushfire-prone areas, following alignment with the 1999 version of AS 3959; and
 - (iv) change the limitations on winders used in lieu of quarter and half landings within stairways; and
 - (v) include minor technical changes.

1.8 Amendment No. 8

- (a) Amendment No. 8 of the 1996 edition of the BCA was adopted by the Commonwealth, States and Territories as set out in [Table 1.8](#).

Table 1.8 History of adoption of Amendment No. 8 of BCA96

Administration	Adoption Date
Australian Government	1 January 2001
Australian Capital Territory	11 January 2001
New South Wales	1 January 2001
Northern Territory	1 January 2001
Queensland	1 January 2001
South Australia	1 January 2001
Tasmania	1 January 2001
Victoria	1 January 2001
Western Australia	1 January 2001

- (b) The purpose of Amendment No. 8 is to—
- (i) update references to Standards; and
 - (ii) include minor technical changes; and
 - (iii) achieve greater consistency between both Volumes of the BCA for stair construction.

1.9 Amendment No. 9

- (a) Amendment No. 9 of the 1996 edition of the BCA was adopted by the Commonwealth, States and Territories as set out in [Table 1.9](#).

History of Amendments

Table 1.9 History of adoption of Amendment No. 9 of BCA96

Administration	Adoption Date
Australian Government	1 July 2001
Australian Capital Territory	12 July 2001
New South Wales	1 July 2001
Northern Territory	1 July 2001
Queensland	1 July 2001
South Australia	2 July 2001
Tasmania	1 July 2001
Victoria	1 July 2001
Western Australia	1 July 2001

- (b) The purpose of Amendment No. 9 is to—
- (i) update references to Standards; and
 - (ii) include minor technical changes; and
 - (iii) clarify which glazing assemblies must comply with AS 2047 and which must comply with AS 1288.

1.10 Amendment No. 10

- (a) Amendment No. 10 of the 1996 edition of the BCA was adopted by the Commonwealth, States and Territories as set out in [Table 1.10](#).

Table 1.10 History of adoption of Amendment No. 10 of BCA96

Administration	Adoption Date
Australian Government	1 January 2002
Australian Capital Territory	1 January 2002
New South Wales	1 January 2002
Northern Territory	1 January 2002
Queensland	1 January 2002
South Australia	1 January 2002 (except SA2—date to be advised)
Tasmania	1 January 2002
Victoria	1 January 2002
Western Australia	1 January 2002

- (b) The purpose of Amendment No. 10 is to—
- (i) update references to Standards; and
 - (ii) update the requirements for protective coatings for steelwork in locations near saltwater; and
 - (iii) align [Figure 3.6.1](#) dealing with glazing with AS 1288; and
 - (iv) extend the concession for fire separation of windows in non-habitable rooms to windows in bathrooms, laundries and toilets and also include buildings on the same allotment; and
 - (v) replace testing to AS/NZS 1530.3 for timber in bushfire areas with reference to AS/NZS 3837; and
 - (vi) include minor technical changes.

1.11 Amendment No. 11

- (a) Amendment No. 11 of the 1996 edition of the BCA was adopted by the Commonwealth, States and Territories as set out in [Table 1.11](#).

Table 1.11 History of adoption of Amendment No. 11 of BCA96

Administration	Adoption Date
Australian Government	1 July 2002
Australian Capital Territory	1 July 2002 (except Australian Capital Territory additions—

History of Amendments

Administration	Adoption Date
	which was adopted on 21 June 2002)
New South Wales	1 July 2002
Northern Territory	1 July 2002
Queensland	1 July 2002
South Australia	1 July 2002
Tasmania	1 July 2002
Victoria	1 July 2002
Western Australia	1 July 2002

- (b) The purpose of Amendment No. 11 is to—
- (i) update references to Standards; and
 - (ii) transfer public policy matters, with respect to structural adequacy, from the AS 1170 series to the BCA; and
 - (iii) introduce new definitions and more detailed provisions on the installation of *flashings* and *damp-proof courses*; and
 - (iv) include minor technical changes.

1.12 Amendment No. 12

- (a) Amendment No. 12 of the 1996 edition of the BCA was adopted by the Commonwealth, States and Territories as set out in [Table 1.12](#).

Table 1.12 History of adoption of Amendment No. 12 of BCA96

Administration	Adoption Date
Australian Government	1 January 2003
Australian Capital Territory	1 January 2003
New South Wales	1 January 2003
Northern Territory	1 January 2003
Queensland	1 January 2003
South Australia	1 January 2003
Tasmania	1 January 2003
Victoria	1 January 2003
Western Australia	1 January 2003

- (b) The purpose of Amendment No. 12 is to—
- (i) update references to Standards; and
 - (ii) allow the use of either the 1989 editions or the 2002 editions of the 1170 series of standards; and
 - (iii) include Energy Efficiency measures into the *Housing Provisions*; and
 - (iv) include minor technical changes.

Note:

Only substantive typographical corrections are noted in the margin.

1.13 Amendment No. 13

- (a) Amendment No. 13 of the 1996 edition of the BCA was adopted by the Commonwealth, States and Territories as set out in [Table 1.13](#).

Table 1.13 History of adoption of Amendment No. 13 of BCA96

Administration	Adoption Date
Australian Government	1 July 2003
Australian Capital Territory	1 July 2003

History of Amendments

Administration	Adoption Date
New South Wales	1 July 2003
Northern Territory	1 July 2003
Queensland	1 July 2003 (except for Parts 2.6 and 3.12 which are adopted on 1 September 2003)
South Australia	1 July 2003
Tasmania	1 July 2003
Victoria	1 July 2003
Western Australia	1 July 2003

(b) The purpose of Amendment No. 13 is to—

- (i) update references to Standards; and
- (ii) refine the Energy Efficiency provisions and advise of their adoption in Western Australia and Queensland; and
- (iii) include minor technical changes.

Note:

Only substantive typographical corrections are noted in the margin.

2.0 Adoption of BCA 2004

The 2004 edition of the BCA was adopted by the Commonwealth, States and Territories as set out in [Table 2.0](#).

Table 2.0 History of adoption of BCA 2004

Administration	Adoption Date
Australian Government	1 May 2004
Australian Capital Territory	1 May 2004
New South Wales	1 May 2004
Northern Territory	1 May 2004
Queensland	1 May 2004
South Australia	1 May 2004
Tasmania	1 May 2004
Victoria	1 May 2004
Western Australia	1 May 2004

(b) The purpose of BCA 2004 is to—

- (i) remove references to BCA 96; and
- (ii) clarify the method of determining the Performance Requirements that are relevant to Alternative Solutions; and
- (iii) update references to other documents; and
- (iv) revise the acceptable construction practice for footing and slab construction; and
- (v) prohibit the use of lead on roofs used to collect potable water; and
- (vi) reform the provisions for sound insulation; and
- (vii) update the Energy Efficiency provisions; and
- (viii) include minor technical changes.

3.0 Adoption of BCA 2005

(a) The 2005 edition of the BCA was adopted by the Commonwealth, States and Territories as set out in [Table 3.0](#).

Table 3.0 History of adoption of BCA 2005

Administration	Adoption Date
Australian Government	1 May 2005

History of Amendments

Administration	Adoption Date
Australian Capital Territory	1 May 2005
New South Wales	1 May 2005
Northern Territory	1 May 2005
Queensland	1 May 2005
South Australia	1 May 2005
Tasmania	1 May 2005
Victoria	1 May 2005
Western Australia	1 May 2005

- (b) The purpose of BCA 2005 is to—
- (i) update references to other documents; and
 - (ii) update the provisions for waterproofing of wet areas; and
 - (iii) update balustrading provisions to include wire balustrades; and
 - (iv) include minor technical changes.

4.0 Adoption of BCA 2006

- (a) The 2006 edition of the BCA was adopted by the Commonwealth, States and Territories as set out in [Table 4.0](#).

Table 4.0 History of adoption of BCA 2006

Administration	Adoption Date
Australian Government	1 May 2006
Australian Capital Territory	1 May 2006
New South Wales	1 May 2006
Northern Territory	1 May 2006
Queensland	1 May 2006
South Australia	1 May 2006, except for South Australian variations P2.6.2, V2.6.2.3 and 3.12.5.4 and South Australian addition SA2 which were adopted on 1 July 2006. The adoption of South Australian variation clause 3.7.4.2 is yet to be advised.
Tasmania	1 May 2006
Victoria	1 May 2006
Western Australia	1 May 2006

- (b) The purpose of BCA 2006 is to—
- (i) update references to other documents; and
 - (ii) convert the W wind speed categories to the N and C wind speed categories; and
 - (iii) include a national testing regime for cladding in cyclonic areas; and
 - (iv) include enhanced energy efficiency provisions; and
 - (v) include minor technical changes.

5.0 Adoption of BCA 2007

- (a) The 2007 edition of the BCA was adopted by the Commonwealth, States and Territories as set out in [Table 5.0](#).

Table 5.0 History of adoption of BCA 2007

Administration	Adoption Date
Australian Government	1 May 2007
Australian Capital Territory	1 May 2007
New South Wales	1 May 2007

History of Amendments

Administration	Adoption Date
Northern Territory	1 May 2007
Queensland	1 May 2007
South Australia	1 May 2007, excluding South Australian variation clause 3.7.4.2, (for the purposes of sub-clauses (1) and (2) of Schedule 18 of the Development Regulations 1993): and sub-clause c) of variation clause 3.7.4.2 (for the purpose of sub-clauses (3) and (4) of Schedule 18 of the Development Regulations 1993).
Tasmania	1 May 2007
Victoria	1 May 2007
Western Australia	1 May 2007

- (b) The purpose of BCA 2007 is to—
- (i) update references to other documents; and
 - (ii) clarify that compliance with either the appropriate acceptable construction manuals or the appropriate acceptable construction practice set out in Section 3 is deemed to comply with the *Performance Requirements*; and
 - (iii) clarify when it is appropriate to use the acceptable construction practice for the installation of glazing and when it is necessary for windows to comply with AS 2047; and
 - (iv) update acceptable construction practice for the installation of glazing to align with recent changes to AS 1288; and
 - (v) update Energy Efficiency provisions including providing clarification and additional information; and
 - (vi) include minor technical changes.

6.0 Adoption of BCA 2008

- (a) The 2008 edition of the BCA was adopted by the Commonwealth, States and Territories as set out in [Table 6.0](#).

Table 6.0 History of adoption of BCA 2008

Administration	Adoption Date
Australian Government	1 May 2008
Australian Capital Territory	1 May 2008
New South Wales	1 May 2008
Northern Territory	1 May 2008
Queensland	1 May 2008
South Australia	1 May 2008
Tasmania	1 May 2008
Victoria	1 May 2008
Western Australia	1 May 2008

- (b) The purpose of BCA 2008 is to—
- (i) update references to other documents; and
 - (ii) include lists of other legislation affecting buildings in the various States and Territories; and
 - (iii) include provisions for swimming pool water recirculation systems; and
 - (iv) include minor technical changes.

7.0 Adoption of BCA 2009

- (a) The 2009 edition of the BCA was adopted by the Commonwealth, States and Territories as set out in [Table 7.0](#).

History of Amendments

Table 7.0 History of adoption of BCA 2009

Administration	Adoption Date
Australian Government	1 May 2009
Australian Capital Territory	1 May 2009
New South Wales	1 May 2009
Northern Territory	1 May 2009
Queensland	1 May 2009
South Australia	1 May 2009
Tasmania	1 May 2009
Victoria	1 May 2009
Western Australia	1 May 2009

- (b) The purpose of BCA 2009 is to—
- (i) update references to other documents; and
 - (ii) after expiry of the agreed transition period, except for the 1993 edition of AS 1170.4, delete all references to the older loading standards contained in the AS 1170 series and consequently, all provisions referring to them; and
 - (iii) simplify the wire balustrade provisions including the addition of a *Verification Method*; and
 - (iv) clarify the height of rooms in an attic and with a sloping ceiling; and
 - (v) clarify the provisions for the construction of *sanitary compartments* to enable an unconscious occupant to be removed; and
 - (vi) further update the energy efficiency provisions; and
 - (vii) include minor technical changes.

8.0 Adoption of BCA 2010

- (a) The 2010 edition of the BCA was adopted by the Commonwealth, States and Territories as set out in [Table 8.0](#).

Table 8.0 History of adoption of BCA 2010

Administration	Adoption Date
Australian Government	1 May 2010
Australian Capital Territory	1 May 2010
New South Wales	1 May 2010
Northern Territory	1 May 2010
Queensland	1 May 2010
South Australia	1 May 2010 except for Parts 2.6 and 3.12, which were adopted on 1 September 2010, and the restriction on child resistant door sets in 3.9.3.0 and the additional bushfire requirements for 'excluded areas' prescribed in SA 3.7.4.2(d) and (e), which were adopted on 2 December 2010.
Tasmania	1 May 2010
Victoria	1 May 2010
Western Australia	1 May 2010

- (b) The purpose of BCA 2010 is to—
- (i) update references to other documents; and
 - (ii) delete reference to the 1993 edition of AS 1170.4 and consequently all provisions referring to it; and
 - (iii) increase the stringency of the energy efficiency provisions and, as part of reducing greenhouse gas emissions, introduce provisions for lighting and the greenhouse gas intensity of the energy source for services such as water and space heaters; and
 - (iv) update [Part 3.7.4](#), as a consequence of referencing the 2009 edition of AS 3959 Construction of buildings in bushfire-prone areas, including—

History of Amendments

- (A) applying the provisions to a Class 10a building or deck associated with a Class 1 building; and
- (B) the deletion of the acceptable construction practice; and
- (v) include minor technical changes.

9.0 Adoption of BCA 2011

- (a) The 2011 edition of the BCA was adopted by the Commonwealth, States and Territories as set out in [Table 9.0](#).

Table 9.0 History of adoption of BCA 2011

Administration	Adoption Date
Australian Government	1 May 2011
Australian Capital Territory	1 May 2011
New South Wales	1 May 2011
Northern Territory	1 May 2011
Queensland	1 May 2011
South Australia	1 May 2011
Tasmania	1 May 2011
Victoria	1 May 2011
Western Australia	1 May 2011

- (b) The purpose of BCA 2011 is to—
- (i) update references to other documents; and
 - (ii) include provisions for *private bushfire shelters* for Class 1 dwellings; and
 - (iii) revise the definition of Class 1b buildings; and
 - (iv) include minor technical changes.

10.0 Adoption of BCA 2012

- (a) The 2012 edition of the BCA was adopted by the Commonwealth, States and Territories as set out in [Table 10.0](#).

Table 10.0 History of adoption of BCA 2012

Administration	Adoption Date
Australian Government	1 May 2012
Australian Capital Territory	1 May 2012
New South Wales	1 May 2012
Northern Territory	1 May 2012
Queensland	1 May 2012
South Australia	1 May 2012
Tasmania	1 May 2012
Victoria	1 May 2012
Western Australia	1 May 2012

- (b) The purpose of BCA 2012 is to—
- (i) update references to other documents; and
 - (ii) include revised provisions aimed at reducing slips, trips and falls in buildings; and
 - (iii) remove the acceptable construction practice for masonry following the referencing of AS 4773 Masonry for small buildings, and completion of a 12 month transition period; and
 - (iv) restructure the acceptable construction practice for wet areas; and
 - (v) include minor technical changes.

History of Amendments

11.0 Adoption of BCA 2013

(a) The 2013 edition of the BCA was adopted by the Commonwealth, States and Territories as set out in [Table 11.0](#).

Table 11.0 History of adoption of BCA 2013

Administration	Adoption Date
Australian Government	1 May 2013
Australian Capital Territory	1 May 2013
New South Wales	1 May 2013
Northern Territory	1 May 2013
Queensland	1 May 2013
South Australia	1 May 2013
Tasmania	1 May 2013
Victoria	1 May 2013
Western Australia	1 May 2013

(b) The purpose of BCA 2013 is to—

- (i) update references to other documents; and
- (ii) include new provisions for openable windows to reduce falls in buildings; and
- (iii) include a Performance Requirement and reference a Standard for construction in flood hazard areas; and
- (iv) include minor technical changes.

12.0 Adoption of BCA 2014

(a) The 2014 edition of the BCA was adopted by the Commonwealth, States and Territories as set out in [Table 12.0](#).

Table 12.0 History of adoption of BCA 2014

Administration	Adoption Date
Australian Government	1 May 2014
Australian Capital Territory	1 May 2014
New South Wales	1 May 2014
Northern Territory	1 May 2014
Queensland	1 May 2014
South Australia	1 May 2014
Tasmania	1 May 2014
Victoria	1 May 2014
Western Australia	1 May 2014

(b) The purpose of BCA 2014 is to—

- (i) update references to other documents; and
- (ii) quantify slip resistance on stair treads in Class 1 buildings; and
- (iii) relocate the energy efficiency provisions for heated water systems to NCC Volume Three - Plumbing Code of Australia; and
- (iv) expand the energy efficiency heating options for swimming pools and associated spa pools; and
- (v) include a new acceptable construction practice for hardboard cladding; and
- (vi) include minor technical changes.

13.0 Adoption of BCA 2015

(a) The 2015 edition of the BCA was adopted by the Commonwealth, States and Territories as set out in [Table 13.0](#).

History of Amendments

Table 13.0 History of adoption of BCA 2015

Administration	Adoption Date
Australian Government	1 May 2015
Australian Capital Territory	1 May 2015
New South Wales	1 May 2015
Northern Territory	1 May 2015
Queensland	1 May 2015
South Australia	1 May 2015
Tasmania	1 May 2015
Victoria	1 May 2015
Western Australia	1 May 2015

- (b) The purpose of BCA 2015 is to—
- (i) update references to other documents; and
 - (ii) include a Verification Method for structural reliability; and
 - (iii) include a Verification Method for weatherproofing of external walls; and
 - (iv) include revised Acceptable Construction Practice for termite management systems.

14.0 Adoption of NCC Volume Two 2016

- (a) The 2016 edition of NCC Volume Two was adopted by the Commonwealth, States and Territories as set out in [Table 14.0](#).

Table 14.0 History of adoption of NCC Volume Two 2016

Administration	Adoption Date
Australian Government	1 May 2016
Australian Capital Territory	1 May 2016
New South Wales	1 May 2016
Northern Territory	1 May 2016
Queensland	1 May 2016
South Australia	1 May 2016
Tasmania	1 May 2016
Victoria	1 May 2016
Western Australia	1 May 2016

- (b) The purpose of NCC Volume Two 2016 is to—
- (i) update references to other documents; and
 - (ii) amend the “Introduction” and “General Requirements” as part of the initiative to increase the use of Performance Solutions; and
 - (iii) include new Verification Methods for structural robustness and indoor air quality; and
 - (iv) include changes as a result of the Acceptable Construction Practice Review project, including the provisions for termite risk management, subfloor ventilation, facilities, light and ventilation and stair construction; and
 - (v) include requirements for overflow of eaves gutters; and
 - (vi) include minor technical changes.

15.0 Adoption of NCC Volume Two 2019

- (a) The 2019 edition of NCC Volume Two was adopted by the Commonwealth, States and Territories as set out in [Table 15.0](#).

History of Amendments

Table 15.0 History of adoption of NCC Volume Two 2019

Administration	Adoption Date
Australian Government	1 May 2019
Australian Capital Territory	1 May 2019
New South Wales	1 May 2019
Northern Territory	1 May 2019
Queensland	1 May 2019
South Australia	1 May 2019
Tasmania	1 May 2019
Victoria	1 May 2019
Western Australia	1 May 2019

(b) The purpose of NCC Volume Two 2019 is to—

- (i) include the Governing Requirements, that result from revision of Part 1 to improve readability and are common to all volumes; and
- (ii) introduce the use of schedules that are common to all volumes; and
- (iii) include new Verification Methods; and
- (iv) include changes resulting from review of acceptable construction practice, including amendments for earthworks, masonry, roof and wall cladding, fire safety and alpine areas; and
- (v) update references to other documents; and
- (vi) include minor technical changes.

List of Amendments

List of amendments—NCC 2019—Housing provisions

List of Amendments

List of amendments—NCC 2019—Housing provisions

List of amendments—NCC 2019—Housing provisions

This set of notes has been prepared by the Australian Building Codes Board to assist NCC users in identifying changes incorporated in the 2019 edition of the Housing Provisions (Volume Two of the NCC).

The notes provide a description of major changes made from the previous edition of the Housing Provisions.

While the Australian Building Codes Board has attempted to include all major changes made from the previous edition of the Housing Provisions, the Board does not give any warranty nor accept any liability in relation to the contents of this list of amendments.

General

Reference	Changes and Commentary
Throughout	The structure of tables has been revised to improve accessibility in accordance with obligations of the Web Content Accessibility Guidelines (WCAG).

Introduction to the NCC

Reference	Changes and Commentary
Introduction	The introduction to the NCC has been revised as a part of the initiative to improve the readability of the NCC.

Governing Requirements

Reference	Changes and Commentary
Section 1	1.0, 1.2 and 1.3 of Part 1 have been removed and replaced with Section 1, the Governing Requirements of the NCC, as part of the initiative to improve the readability of the NCC. 1.1.1 Definitions and 1.4.1 Schedule of Referenced Documents have been removed and replaced with Schedules 3 and 4 respectively.

Performance provisions

Reference	Changes and Commentary
V2.1.1	Verification Method V2.1.1 has been amended to reflect the outcome of technical review. V2.1.1 is a means of verifying the reliability of a structural component.
V2.3.1.1	A new Verification Method has been added as an option to verify compliance with P2.3.1(a)(i). V2.3.1.1 is a means to verify the protection of Class 1 buildings from fire spread from another building, other than an associated Class 10 building, when on the same allotment.
V2.3.1.2	A new Verification Method has been added as an option to verify compliance with P2.3.1(a)(ii). V2.3.1.2 is a means to verify the protection of Class 1 buildings from fire spread from the allotment boundary.
V2.3.1.3	A new Verification Method has been added as an option to verify compliance with P2.3.1(b). V2.3.1.3 is a means to verify that a Class 10a building does not significantly increase the risk of fire spread between Class 2 to 9 buildings on adjoining allotments.
V2.3.1.4	A new Verification Method has been added as an option to verify compliance with P2.3.1(b). V2.3.1.4 is a means to verify that a Class 10a building does not significantly increase the risk of fire spread between Class 2 to 9 buildings on the same allotment.
P2.4.4	Performance Requirement P2.4.4 has been modified to quantify that natural light must provide an average daylight factor of not less than 2% and that artificial lighting must achieve a level of illuminance not less than 20 lux.
P2.4.7	A new Performance Requirement has been added. P2.4.7 contains requirements for the management of risks associated with water vapour and condensation.
V2.4.2	A new Verification Method has been added as an option to verify compliance with Performance Requirement P2.4.2. V2.4.2 is a means for verifying the provision of sufficient height for a room or space.
V2.4.4	A new Verification Method has been added as an option to verify compliance with P2.4.4(a). V2.4.4 is a means for verifying the suitable provision of natural light.
V2.6.2.2	Verification Method V2.6.2.2 has been amended. Changes include the specification of reference

List of Amendments

Reference	Changes and Commentary
	building parameters.
V2.6.2.3	A new Verification Method has been added as an option for certain buildings to demonstrate compliance with P2.6.1(f) for building sealing. V2.6.2.3 is a means of verifying the sealing of buildings by air leakage testing.
Part 2.7	Performance Requirements for swimming pools, heating appliances, alpine areas and bushfire areas have been relocated to this new part, 'Ancillary provisions and additional construction requirements'.
V2.7.1	A new Verification Method has been added as an option to verify compliance with P2.7.3(a) and (b). V2.7.1 is a means for verifying the robustness of combustion appliances.
V2.7.2	A new Verification Method has been added as an option to verify compliance with P2.7.5. V2.7.2 is a means for verifying construction in bushfire prone areas.

How to use Section 3

Reference	Changes and Commentary
How to use Section 3	This guide has been updated to reflect amendments to the Housing Provisions.

Part 3.0 Structural provisions

Reference	Changes and Commentary
Part 3.0	A new Part has been added. Part 3.0 Structural Provisions contains content relocated from Parts 3.10 'High wind areas' and 3.11 'Structural provisions'.

Part 3.1 Site preparation

Reference	Changes and Commentary
3.1.1	Amended as a result of the Acceptable Construction Practice Review project. The changes clarify the provisions and use current terminology.
3.1.2	A new Part, 'Earth retaining structures' has been added. Part 3.1.2 references the acceptable construction manual for earth retaining structures such as retaining walls. Numbering throughout Part 3.1 'Site preparation' has been amended as a consequence of the introduction of this Part.
3.1.3.0	AS/NZS 3500.5 has been removed from the list of acceptable construction manuals.

Part 3.3 Masonry

Reference	Changes and Commentary
3.3.5	A new Part, 'Masonry veneer', has been added. Part 3.3.5 contains provisions, including new acceptable construction practice, for masonry veneer construction.
3.3.6	A new Part, 'Isolated masonry piers' has been added.

Part 3.4 Framing

Reference	Changes and Commentary
3.4.1.2	Durability requirements for in-ground subfloor timber framing have been added.
3.4.2	Acceptable construction practice for steel framing has been removed.
3.4.3.0	The list of acceptable construction manuals has been amended to include AS 1720.1, AS 1720.5, AS 1684.3 and AS 1860.2.

Part 3.5 Roof cladding, gutters and downpipes, and wall cladding

Reference	Changes and Commentary
3.5	The Part has been re-named and content location has been changed as a result of the Acceptable Construction Practice Review project.
3.5.0.1	A new Part, 'Explanation of terms', has been added.
3.5.1	Part 3.5.1 has been re-named and groups provisions relevant to sheet roofing.
3.5.2	Part 3.5.2 has been re-named and groups provisions relevant to tile and shingle roofing.
3.5.2.0	AS 2049, AS/NZS 4256 Parts 1, 2, 3 and 5, AS/NZS 1562.3, AS/NZS 1562.2, ASTM D3018-90 and

List of Amendments

Reference	Changes and Commentary
	AS/NZS 4200 Part 1 and AS 4200 Part 2 have been removed from the list of acceptable construction manuals.
3.5.3.0	AS/NZS 3500.5 has been removed from the list of acceptable construction manuals.
3.5.4	Part 3.5.4, 'Timber, metal and composite cladding', has been added and contains provisions relevant to these cladding types.
3.5.4.6	More detailed requirements for wall flashings have been included.
3.5.4.7	A new provision has been added requiring minimum clearances between the ground and wall cladding.
3.5.4.8	A new provision has been added outlining requirements for wall claddings used to form a parapet.
3.5.5	Part 3.5.5, 'Metal wall cladding', has been added to group requirements for metal wall cladding.

Part 3.7 Fire safety

Reference	Changes and Commentary
3.7.1	The provisions of Part 3.7.1 have been relocated to other Parts of 3.7. A new Part, 'Fire properties for materials and construction', has been added and combines existing requirements for fire properties.
3.7.2	Part 3.7.2 has been re-named to 'Fire separation of external walls' and combines requirements for external walls. Amendments to existing provisions to improve clarity have been made as a result of the Acceptable Construction Practice Review project.
Figure 3.7.2.4	Additional requirements have been added for where an appurtenant Class 10a building is adjacent to a Class 1 building but not located between the boundary and the Class 1 building.
Figure 3.7.2.4	Additional requirements have been added for where an appurtenant Class 10a building is adjacent to a Class 1 building but not located between the Class 1 building and another building on the same site.
3.7.3	Part 3.7.3 has been re-named to 'Fire protection of separating walls and floors' and combines requirements for separating walls and floors. Amendments to existing provisions to improve clarity have been made as a result of the Acceptable Construction Practice Review project.
3.7.3.5	A new provision, 'Horizontal projections', has been added. Part 3.7.3.5 contains requirements for cantilevered floors that contain a separating wall.
3.7.4	Part 3.7.4 has been re-named to 'Fire separation of garage top dwellings' and combines requirements for garage top dwellings. The provisions have been restructured and amended to clarify separation requirements for appurtenant and non-appurtenant private garages located below a Class 1a dwelling.
3.7.5	Part 3.7.3.5 has been re-named to 'Smoke alarms and evacuation lighting' and contains requirements previously located in Part 3.7.2. Amendments to improve clarity have been made as a result of the Acceptable Construction Practice Review project.

Part 3.8 Health and amenity

Reference	Changes and Commentary
3.8.1	In Table 3.8.1.1 the requirement for the wall / floor junction for laundries and WCs has been changed from waterproof to water resistant.
3.8.4	New explanatory information has been added to clarify why 3.8.4.2 prescribes a smaller light transmitting area for a roof light as compared to a window.
3.8.5.2(c)	Amended on account of new provisions relating to exhaust discharge found in 3.8.7.3. The explanatory information for this clause has been deleted, also on account of 3.8.7.3.
3.8.6	Amendments to improve clarity have been made as a result of the Acceptable Construction Practice Review project.
3.8.7	A new Part, 'Condensation management', has been added. This Part includes provisions for the installation of water control membranes, ventilation of roof spaces and the discharge of exhaust systems. This has occurred to minimise the impacts of risks associated with water vapour and condensation on occupants.

List of Amendments

Part 3.9 Safe movement and access

Reference	Changes and Commentary
3.9.2	Amendments to improve clarity have been made as a result of the Acceptable Construction Practice Review project.

Part 3.10 Ancillary provisions and additional construction requirements

Reference	Changes and Commentary
3.10.1	The provisions for swimming pools have been relocated to Part 3.10.1.
3.10.4	The provisions for alpine areas have been relocated to Part 3.10.4. Amendments to improve clarity have been made as a result of the Acceptable Construction Practice Review project.
3.10.5	The provisions for construction in bushfire areas have been relocated to Part 3.10.5.
3.10.6	A new Part, 'Attachment of decks and balconies to external walls of buildings', has been added as a result of the Acceptable Construction Practice Review project.
3.10.7	The provisions for heating appliances have been relocated to 3.10.7. Clarification amendments have also been made.

Part 3.12 Energy efficiency

Reference	Changes and Commentary
3.12	Amendments, including insertion of additional explanatory information, have been made to improve readability. A transition period has been applied to this Part.
3.12.0.1(a)	Amended to clarify that star ratings must include separate heating and cooling loads.
3.12.3.2	Additional explanatory information has been added to clarify the requirements in 3.12.3.2 regarding sealing of roof lights.
3.12.3.3	Sub-clause (a) has been amended to require the sealing of a door between a Class 1 building and an unconditioned Class 10a part of a building. Additional amendments, including sub-clause (d), set out where sealing must be installed.
3.12.3.5	Amendments have been made to clarify the sealing requirements and improve the performance of building sealing.

Schedule 2—Abbreviations and symbols

Reference	Changes and Commentary
Schedule 2	Schedule 2 has been inserted as part of the initiative to improve the readability of the NCC. Schedule 2 replaces 'Abbreviations and Symbols' and includes all abbreviations and symbols used throughout the NCC.
Abbreviations	Alternating Current (AC) has been added.
Abbreviations	Australian Local Government Association (ALGA) has been deleted.
Abbreviations	Available safe egress time (ASET) has been added.
Abbreviations	Building Codes Committee (BCC) has been deleted.
Abbreviations	Correlated Colour Temperature (CCT) has been added.
Abbreviations	Critical Heat Flux (CHF) has been added.
Abbreviations	Critical Radiant Flux (CRF) has been added.
Abbreviations	Colour Rendition Index (CRI) has been added.
Abbreviations	Direct Current (DC) has been added.
Abbreviations	Heat Release Rate (HRR) has been added.
Abbreviations	Light-Emitting Diode (LED) has been added.
Abbreviations	Minutes (mins) has been added.
Abbreviations	National Australian Built Environment Rating System (NABERS) has been added.
Abbreviations	Nationwide House Energy Rating Scheme (NatHERS) has been added.
Abbreviations	Performance-based design brief (PBDB) has been added.
Abbreviations	Predicted Mean Vote (PMV) has been added.
Abbreviations	Required safe egress time (RSET) has been added.
Symbols	° has been added.

List of Amendments

Reference	Changes and Commentary
Symbols	km has been added.
Symbols	m ² .K/W has been added.
Symbols	m ³ /hour has been added.
Symbols	Pa/m has been added.
Symbols	V has been added.
Symbols	$W_r/W_{input\ power}$ has been added.
Symbols	W/kW_{rej} has been added.

Schedule 3—Defined terms

Reference	Changes and Commentary
Schedule 3	The definitions, previously contained in Part 1.1, have been relocated to Schedule 3 as part of the initiative to improve the readability of the NCC. Schedule 3 includes all defined terms used throughout all volumes of the NCC.
Activity traits	A new defined term has been added as a consequence of including a Verification Method for sufficient height.
Activity support level	A new defined term has been added as a consequence of including a Verification Method for sufficient height.
Average daylight factor	A new defined term has been inserted as a consequence of including a Verification Method for sufficient natural light.
Condensation	A new defined term has been added as a consequence of including new provisions for condensation management.
Interstitial condensation	A new defined term has been added as a consequence of including new provisions for condensation management.
Mould	A new defined term has been added as a consequence of including new provisions for condensation management.
Occupant traits	A new defined term has been added as a consequence of including a Verification Method for sufficient height.
Pliable building membrane	A new defined term has been inserted as a consequence of including provisions for condensation management.
Professional engineer	The defined term has been amended to reflect current names for the Institution of Engineers Australia and the National Engineering Register.
Total R-Value	The defined term has been amended to include its unit.
Vapour pressure	A new defined term has been added as a consequence of including new provisions for condensation management.
Water control layer	A new defined term has been added as a consequence of including new provisions for condensation management.
Water control membrane	A new defined term has been added as a consequence of including new provisions for condensation management.
Water sensitive materials	A new defined term has been added as a consequence of including new provisions for condensation management.

Schedule 4—Documents adopted by reference

Reference	Changes and Commentary
AS/NZS ISO 717.1	The 2004 edition of AS/NZS ISO 717 Part 1 'Acoustics — Rating of sound insulation in buildings and of building elements — Airborne sound insulation' has been referenced. A note has been included to outline transitional arrangements.
AS/NZS 1170.2	Amdts 4 and 5 of the 2011 edition of AS/NZS 1170 Part 2 'Structural design actions — Wind actions' have been referenced.
AS/NZS 1170.3	Amdt 2 of the 2003 edition of AS/NZS 1170 Part 3 'Structural design actions — Snow and ice actions' has been referenced.
AS 1170.4	Amdt 2 of the 2007 edition of AS 1170 Part 4 'Structural design actions — Earthquake actions in Australia' has been referenced.

List of Amendments

Reference	Changes and Commentary
AS/NZS 1276.1	The 1999 edition of AS/NZS 1276 Part 1 'Acoustics — Rating of sound insulation in buildings and of building elements — Airborne sound insulation' has been deleted. A note has been included to outline transitional arrangements.
AS 1288	Amdts 2 and 3 of the 2006 edition of AS 1288 'Glass in buildings — Selection and installation' have been referenced.
AS 1530	The note to AS 1530 permitting use of reports relating to tests carried out under earlier editions of AS 1530 Parts 1, 2 and 4 has been amended to include an expiry date of 1 May 2022.
AS 1562.1	The 2018 edition of AS 1562 Part 1 'Design and installation of sheet roof and wall cladding — Metal' has been referenced. A note provides a transition period for tests carried out based on the 1992 edition of AS 1562 Part 1 meaning that tests carried out previously under the 1992 edition remain valid, however those carried out after the NCC 2019 reference date must be carried out using the 2018 edition.
AS 1562.2	Reference to AS 1562 Part 2 'Design and installation of sheet roof and wall cladding — Corrugated fibre-reinforced cement' has been deleted.
AS 1668.2	The title has been amended to reflect the re-named standard and Amdt 2 of AS 1668.2 'The use of ventilation and air-conditioning in buildings — Mechanical ventilation in buildings' has been referenced.
AS 1670.1	The 2018 edition of AS 1670 Part 1 'Fire detection, warning, control and intercom systems — System design, installation and commissioning — Fire' has been referenced. A note has been included to outline transitional arrangements.
AS/NZS 1859.4	The 2018 edition of AS/NZS 1859 Part 4 'Reconstituted wood-based panels — Specifications — Wet-processed fibreboard' has been referenced. A note has been included to outline transitional arrangements.
AS 1860.2	The 2006 edition of AS 1860 Part 2 'Particleboard flooring — Installation' has been referenced.
AS 2699.1	The 2000 edition of AS/NZS 2699 Part 1 'Built-in components for masonry construction — Wall ties' has been referenced.
AS 2699.3	The 2002 edition of AS/NZS 2699 Part 3 'Built-in components for masonry construction — Lintels and shelf angles (durability requirements)' has been referenced.
AS 2047	Amdts 1 and 2 of the 2014 edition of AS 2047 'Windows and external glazed doors in buildings' have been referenced. A note has been included to outline transitional arrangements.
AS 2050	The 2018 edition of AS 2050 'Installation of roof tiles' has been referenced.
AS/NZS 2918	The 2018 edition of AS/NZS 2918 'Domestic solid-fuel burning appliances — Installation' has been referenced. A note has been included to outline transitional arrangements.
AS/NZS 3500.3	The 2018 edition of AS/NZS 3500 Part 3 'Plumbing and drainage — Stormwater drainage' has been referenced.
AS/NZS 3500.5	Reference to AS/NZS 3500 Part 5 'Plumbing and drainage — Housing installations' has been deleted.
AS 3600	The 2018 edition of AS 3600 'Concrete structures' (incorporating amendment 1) has been referenced.
AS 3660.1	The 2000 edition of AS 3660 Part 1 'Termite management — New building work' has been deleted.
AS 3700	The 2018 edition of AS 3700 'Masonry structures' has been referenced subject to modification that is contained in the NCC where applicable.
AS 3786	The 1993 edition of AS 3786 'Smoke alarms' has been deleted. Amdt 2 of the 2014 edition of AS 3786 'Smoke alarms using scattered light, transmitted light or ionization' has been referenced. A note has been added to enable reports relating to tests carried out under AS 3786 — 2014 Amdt 1 to remain valid but tests carried out after the NCC reference date must use AS 3786 — 2014 Amdt 1 and 2.
AS 3959	The 2018 edition of AS 3959 'Construction of buildings in bushfire-prone areas' has been referenced.
AS 4072.1	The note to AS 4072 Part 1 permitting use of tests carried out under AS 1530.4 prior to 1 January 1995 has been amended to include an expiry date of 1 May 2022.
AS/NZS 4200.1	The 2017 edition of AS/NZS 4200 Part 1 'Pliable building membranes and underlays — Materials' has been referenced.
AS 4200.2	The 2017 edition of AS 4200 Part 2 'Pliable building membranes and underlays — Installation requirements' (incorporating amendment 1) has been referenced.
AS/NZS 4256	Reference to AS/NZS 4256 Parts 1, 2, 3 and 5 'Plastic sheet roofing' have been removed.
AS 4586	Amdt 1 of AS 4586 'Slip resistance classification of new pedestrian surface materials' has been referenced. A note has been included to outline transitional arrangements.

List of Amendments

Reference	Changes and Commentary
AS/NZS 4600	The 2018 edition of AS/NZS 4600 'Cold-formed steel structures' has been referenced.
AS 4678	The 2002 edition of AS 4678 'Earth-retaining structures' has been referenced.
AS 4773.1	Amdt 1 of AS 4773 Part 1 'Masonry for small buildings — Design' has been referenced.
AS/NZS 4859.1	The 2018 edition of AS/NZS 4859 Part 1 'Thermal insulation materials for buildings — General criteria and technical provisions' has been referenced.
AS 5146.1	Amdt 1 of AS 5146 Part 1 'Reinforced Autoclaved Aerated Concrete — Structures' has been referenced.
AS 5216	has been referenced. This replaces SA TS 101 'Design of post-installed and cast-in fastenings for use in concrete' which has been deleted.
AS/NZS ISO 9972	The 2015 edition of AS/NZS ISO 9972 'Thermal performance of buildings — Determination of air permeability of buildings — Fan pressurization method' has been referenced.
ASTM D3018-90	Reference to ASTM D3018-90 'Class A asphalt shingles surfaced with mineral granules' has been deleted.
ASTM E903-12	The 2012 edition of ASTM E903 'Standard test method for solar absorptance, reflectance and transmittance of materials using integrating spheres' has been referenced
ANSI/ASHRAE Standard 140	The 2007 edition of ANSI/ASHRAE Standard 140 'Standard method of test for the evaluation of building energy analysis computer programs' has been referenced.
ABCB	Reference to 'Protocol for Building Energy Analysis Software Version 2006.1' has been deleted.
ABCB	Version 2011.2 of the ABCB 'Protocol for Structural Software' has been referenced.
ABCB	Version 2012.3 of the ABCB 'Standard for Construction of Buildings in Flood Hazard Areas' has been referenced.
SA TS 101	Reference to SA TS 101 'Design of post-installed and cast-in fastenings for use in concrete' has been deleted. This has been replaced by a reference to AS 5216 'Design of post-installed and cast-in fastenings in concrete'.